



M+S HYDRAULIC



SPOOL VALVE HYDRAULIC MOTORS



TYPE MM
MP
MR
MH

SPOOL VALVE HYDRAULIC MOTORS

CONTENTS

	Page
● Hydraulic Motors Series MM	4
● Hydraulic Motors Series MP	12
● Hydraulic Motors Series MR	28
● Hydraulic Motors Series MH	38
● Motor Special Features.....	46
● Motors with Speed Sensor.....	47
● Motor Application	49

SPOOL VALVE HYDRAULIC MOTORS

The operating principle of the motors is based on an internal gear design, consisting of a stator and rotor through which the output torque and speed are transmitted. The distributor valve is driven synchronously by the rotor through a cardan shaft ensuring that each one of the chambers of the motor are filled and emptied precisely.

MM, MP, MR and MH motors have a Spool Valve.

SPOOL VALVE - The distributor valve has been integrated with the output shaft. The valve has hydrodynamic bearings, and has infinite life when load ratings are not exceeded.

GEAR SET - There are two forms of stator, hence and of gear set:

MM and MP have plain teeth. These types motors are suitable for long operating periods at moderate pressures- or short operating periods at high pressures.

MR and MH have teeth fitted with rollers. The rollers reduce local stress and the tangential reaction forces on the rotor reducing friction to a minimum. This gives long operating life and better efficiency even at continuous high pressures. Roller Gear Sets are recommended for operation with thin oil and for applications having continually reversing loads.

Standard Motor The standard motor mounting flange is located as close to the output shaft as possible. This type of mounting supports the motor close to the shaft load. This mounting flange is also compatible with many standard gear boxes.

Wheel Motor This type mounting flange makes the motor possible to fit a wheel hub or a winch drum so that the radial load acts midway between the two motor bearings. This gives the best utilization of the bearing capacity and is a very compact solution.

Needle Bearing MP and MR have an output shaft supported in needle bearing. These types motors are suitable for absorbing static and dynamic radial loads.

Low Leakage **LL** Series hydraulic motors have been designed to operate at the whole standard range of working conditions (pressure drop and frequency of rotation) , but with considerable decreased volumetric losses in the drainage ports. Their main purpose is to operate as series-connected motors in hydraulic systems. For this version is permissible decreasing of the maximal torque with up to 5% (at middle speed) and up to 10 % (at high speed) in comparison to the standard versions of motors.

Low Speed Valve **LSV** Series hydraulic motors have been designed to operate with normal pressure drop and to ensure smooth run at low speed (up to 200 min⁻¹), as the best security for operation is guaranteed at frequency of rotation 20 ÷ 50 min⁻¹. They have an increased starting pressure drop and are not recommended for using at pressure less than 40 bar.

Free Running **FR** Series hydraulic motors have been designed to operate with high frequencies of rotation /over than 300 min⁻¹/ and low pressure drop. These motors are produced with increased clearance at all friction parts. Additional advantages of "FR" version are prolonging of the life of the hydraulic motors at high frequencies of rotation, as well as the possibility to use them in systems with big variation of the loading. Volumetric efficiency can be affected.

HYDRAULIC MOTORS MM



APPLICATION

- » Conveyors
- » Textile machines
- » Mining machinery
- » Machine tools
- » Ventilators
- » Construction plant equipment and access platforms etc.

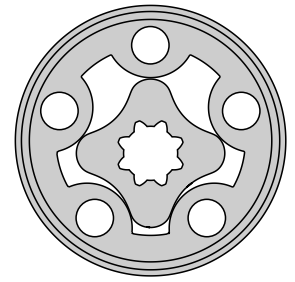

CONTENTS

Specification data 5
 Function diagrams 6÷8
 Dimensions and mounting ... 9
 Shaft extensions 10
 Permissible shaft loads 10
 Order code 11

OPTIONS

- » Model- Spool valve, gerotor
- » With or without flange
- » Side and rear ports
- » Series with pressure valve(s)
- » Shafts- straight and splined
- » Metric and BSPP ports
- » Speed sensing;

GENERAL

Displacement, [cm ³ /rev.]	8,2 ÷ 50
Max. Speed, [RPM]	400 ÷ 1950
Max. Torque, [daNm]	1,1 ÷ 4,5
Max. Output, [kW]	1,8 ÷ 2,4
Max. Pressure Drop, [bar]	70 ÷ 100
Max. Oil Flow, [l/min]	16 ÷ 20
Min. Speed, [RPM]	20 ÷ 50
Pressure fluid	Mineral based- HLP(DIN 51524) or HM(ISO 6743/4)
Temperature range, [°C]	-30 ÷ 90
Optimal Viscosity range, [mm ² /s]	20 ÷ 75
Filtration	ISO code 20/16 (Min. recommended fluid filtration of 25 micron)

MMP Series with Integrated Internal Crossover Relief Valve
 A → B, Δp = 100 bar (50 bar)

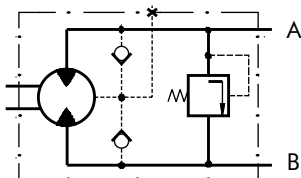

MMP Series with Integrated Internal Crossover Relief Valve
 B → A, Δp = 100 bar (50 bar)

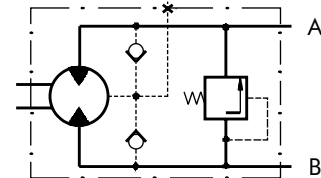

Pressure Losses

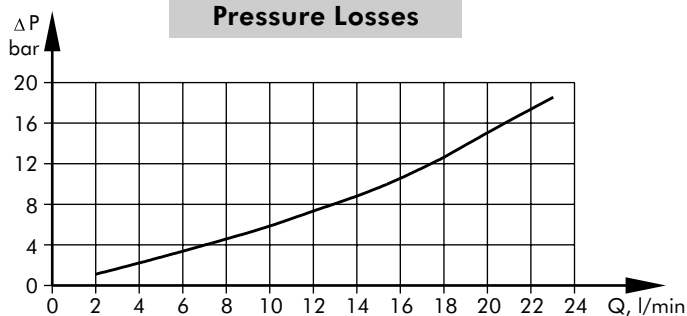

MMD Series with Integrated Internal Crossover Relief Valves
 A ↔ B, Δp = 100 bar (50 bar)

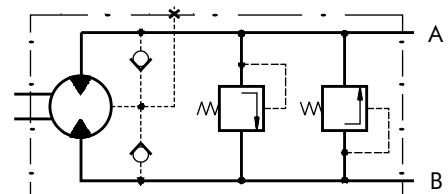

SPECIFICATION DATA

Type		MM 8	MM 12,5	MM 20	MM 32	MM 40	MM 50
Displacement [cm ³ /rev.]		8,2	12,9	20	31,8	40	50
Max. Speed, [RPM]	cont.	1950	1550	1000	630	500	400
	int.*	2440	1940	1250	790	625	500
Max. Torque [daNm]	cont.	1,1	1,6	2,5	4	4,1	4,5
	int.*	1,5	2,3	3,5	5,7	5,7	5,8
	peak**	2,1	3,3	5,1	6,4	6,6	8
Max. Output [kW]	cont.	1,8	2,4	2,4	2,4	1,8	1,7
	int.*	2,6	3,2	3,2	3,2	3,0	2,1
Max. Pressure Drop [bar]	cont.	100	100	100	100	80	70
	int.*	140	140	140	140	110	90
	peak**	200	200	200	200	140	125
Max. Oil Flow [l/min]	cont.	16	20	20	20	20	20
	int.*	20	25	25	25	25	25
Max. Inlet Pressure, [bar]	cont.	140	140	140	140	140	140
	int.*	175	175	175	175	175	175
	peak**	225	225	225	225	225	225
Max. Return Pressure w/o Drain Line or Max. Pressure in Drain Line, [bar]	cont.	0-100 RPM	140	140	140	140	140
	cont.	100-400 RPM	100	100	100	100	100
	cont.	400-800 RPM	50	50	50	50	50
	cont.	>800 RPM	20	20	20	-	-
	int.*	0-max. RPM	140	140	140	140	140
Max. Return Pressure with Drain Line [bar]	cont.	140	140	140	140	140	140
	int.*	175	175	175	175	175	175
	peak**	225	225	225	225	225	225
Max. Starting Pressure with Unloaded Shift, [bar]		4	4	4	4	4	4
Min. Starting Torque [daNm]	at max. press. drop cont.	0,7	1,2	2,1	3,4	3,3	3,7
	at max. press. drop int.*	1,0	1,7	2,9	4,8	4,6	4,8
Min. Speed***, [RPM]		50	40	30	30	25	20
Weight, avg. [kg]	MM	1,9	2	2,1	2,2	2,3	2,5
	MMF(S)	2,3	2,4	2,5	2,6	2,7	2,9
	MMFS	2,7	2,8	2,9	3,0	3,1	3,3
	MMP	2,5	2,6	2,7	2,8	2,9	3,1
	MMPF	2,7	2,8	2,9	3,0	3,1	3,3
	MMD	2,6	2,7	2,8	2,9	3,0	3,2
	MMDF	2,8	2,9	3,0	3,1	3,2	3,4

* Intermittent operation: the permissible values may occur for max. 10% of every minute.

** Peak load: the permissible values may occur for max. 1% of every minute.

*** For speeds of 30 RPM or lower, consult factory or your regional manager.

1. Intermittent speed and intermittent pressure drop must not occur simultaneously.
2. Recommended filtration is per ISO cleanliness code 20/16. A nominal filtration of 25 micron or better.
3. Recommend using a premium quality, anti-wear type mineral based hydraulic oil HLP(DIN51524) or HM (ISO 6743/4).
If using synthetic fluids consult the factory for alternative seal materials.
4. Recommended minimum oil viscosity 13 mm²/s at operating temperature 50°C.
5. Recommended maximum system operating temperature is 82°C.
6. To assure optimum motor life fill with fluid prior to loading and run at moderate load and speed for 15-30 min.

FUNCTION DIAGRAMS

MM 8

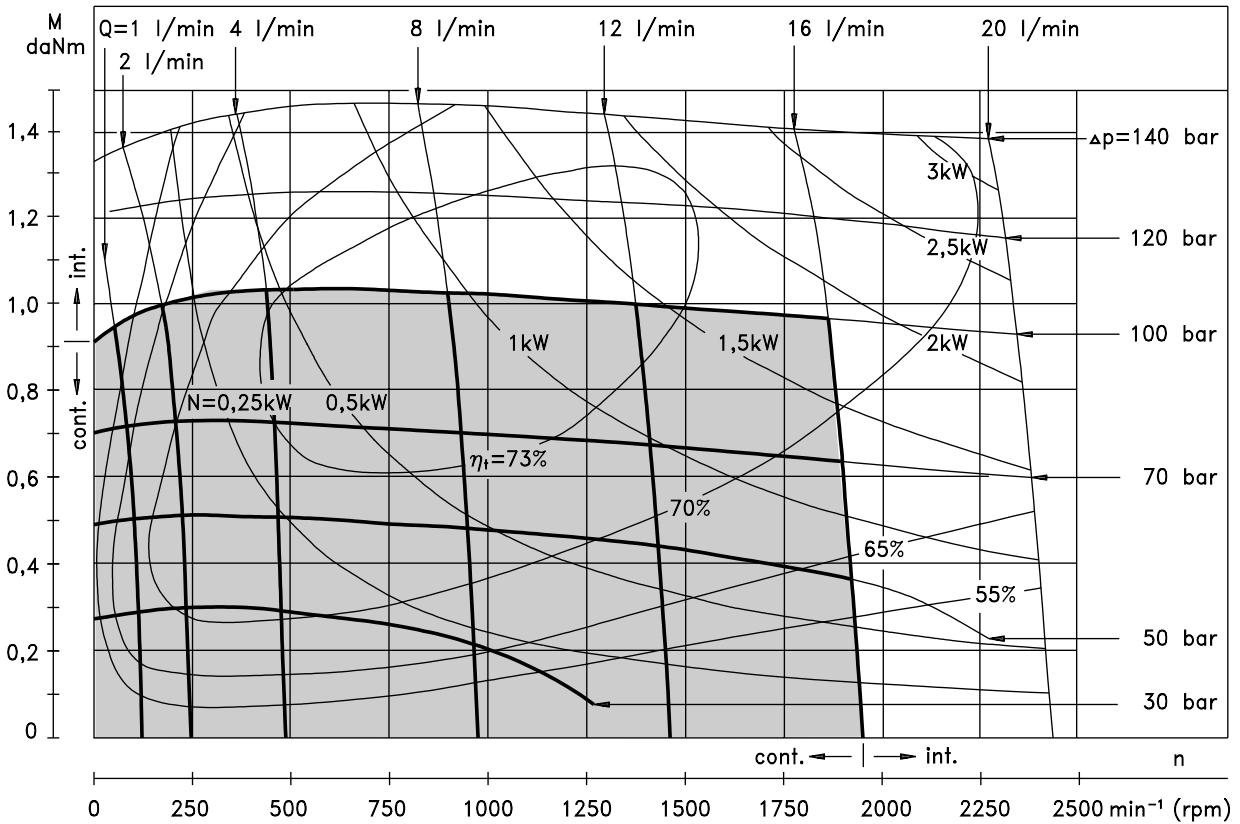

MM 12,5

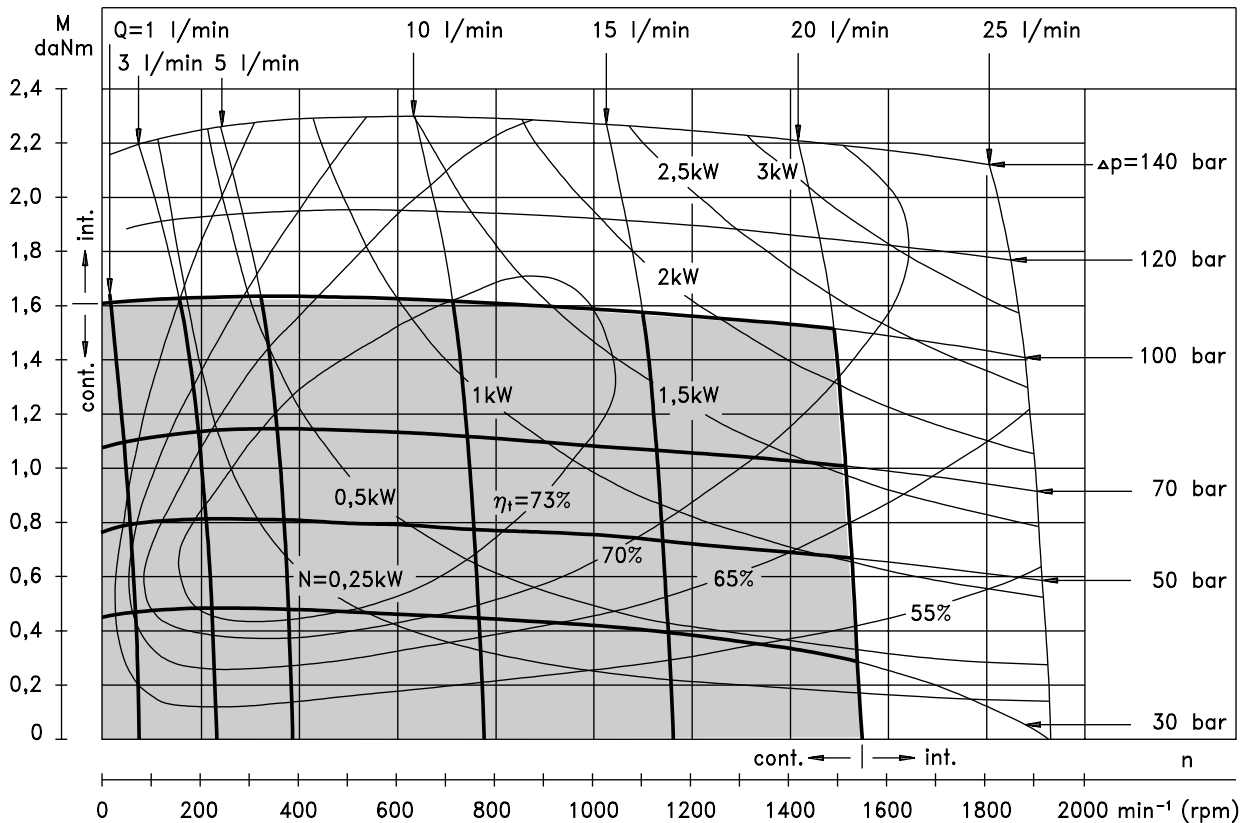

The function diagrams data was collected at back pressure 5÷10 bar and oil with viscosity of 32 mm²/s at 50° C.

FUNCTION DIAGRAMS

MM 20

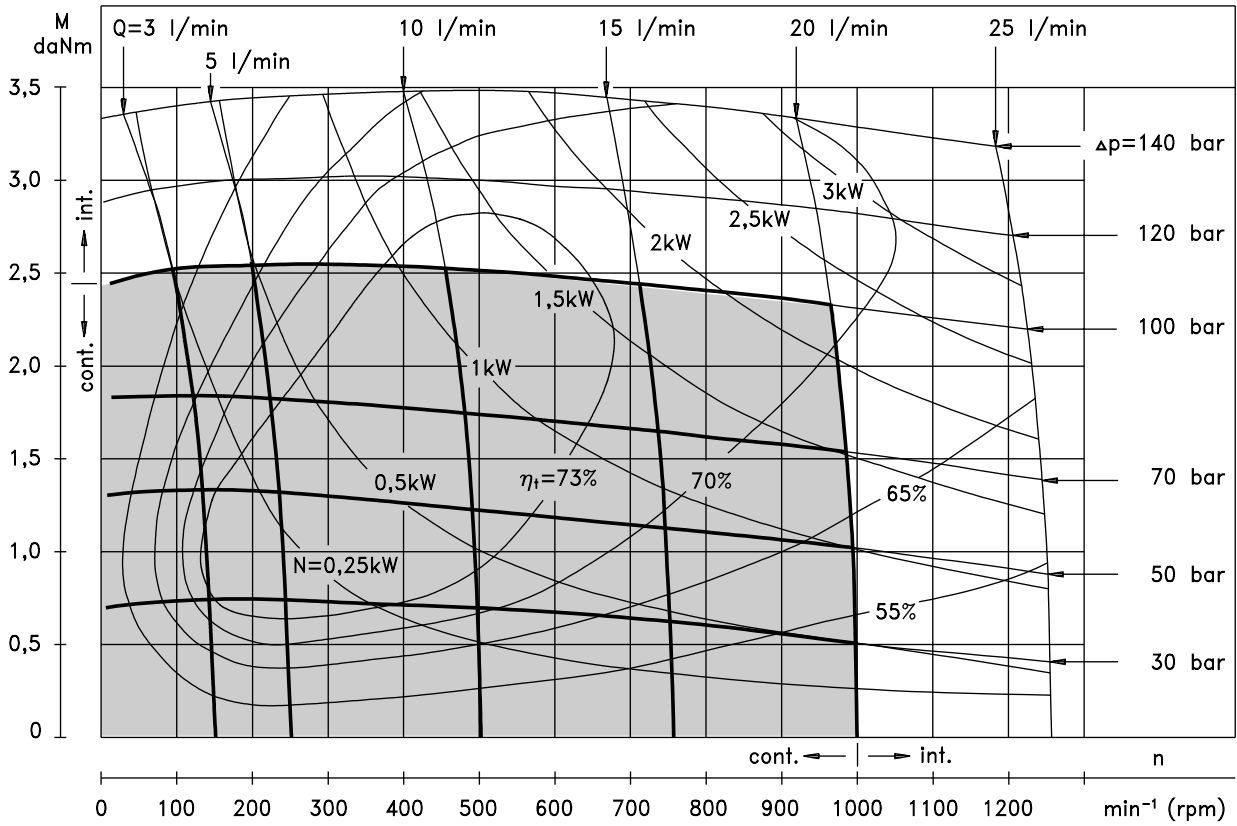

MM 32

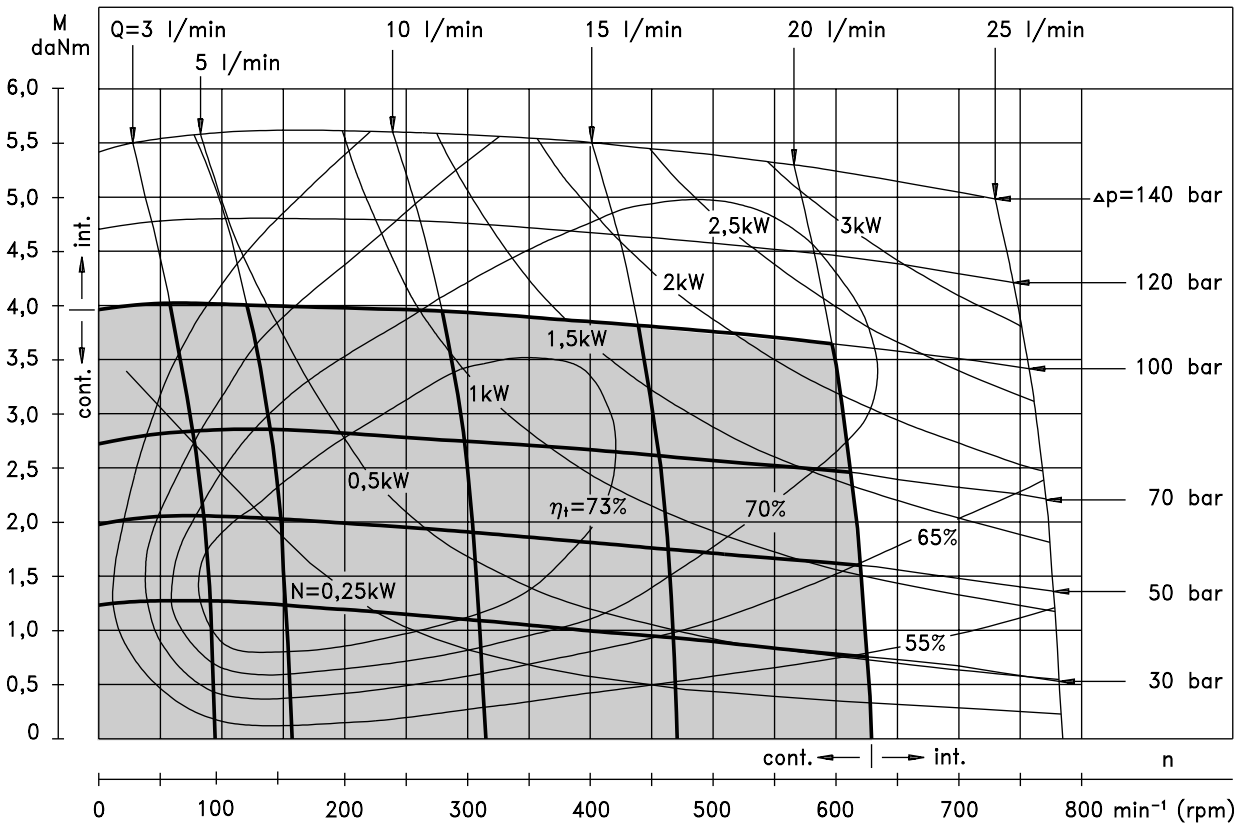

The function diagrams data was collected at back pressure 5 ÷ 10 bar and oil with viscosity of 32 mm²/s at 50° C.

FUNCTION DIAGRAMS

MM 40

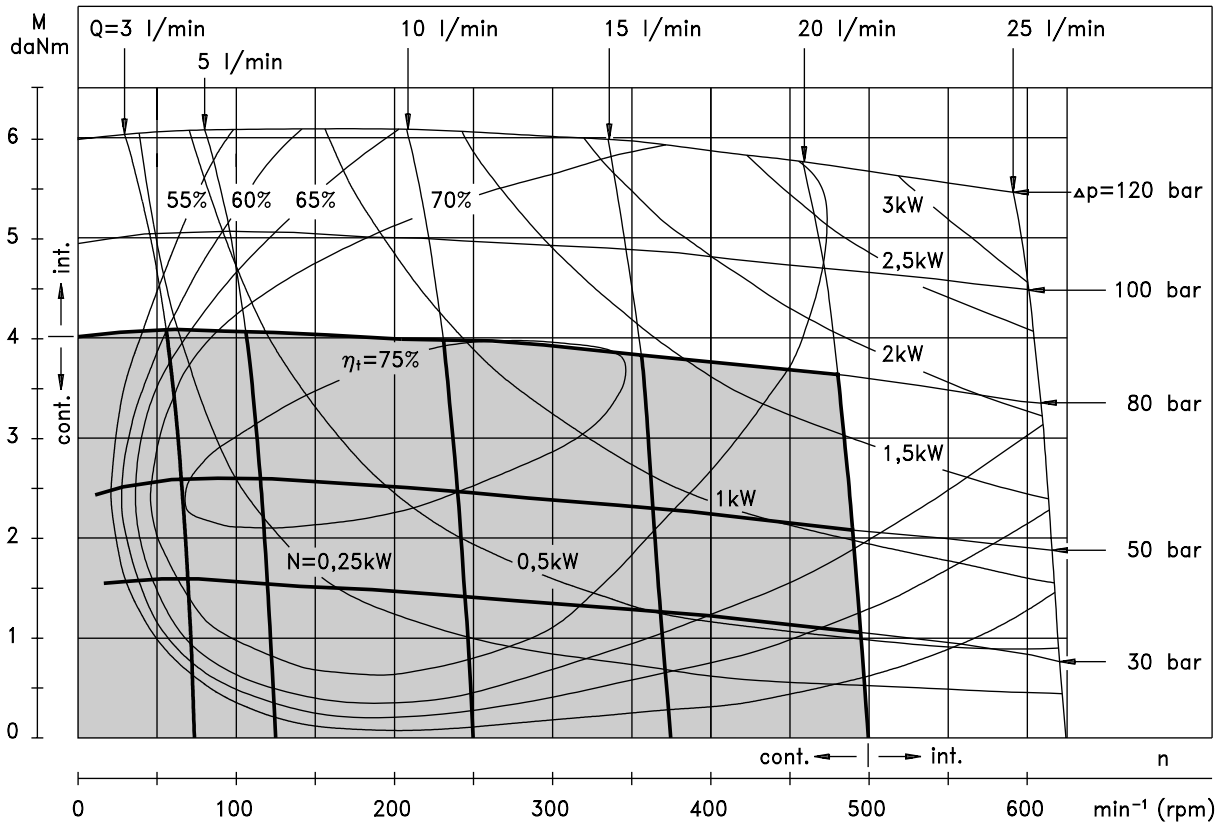

MM 50

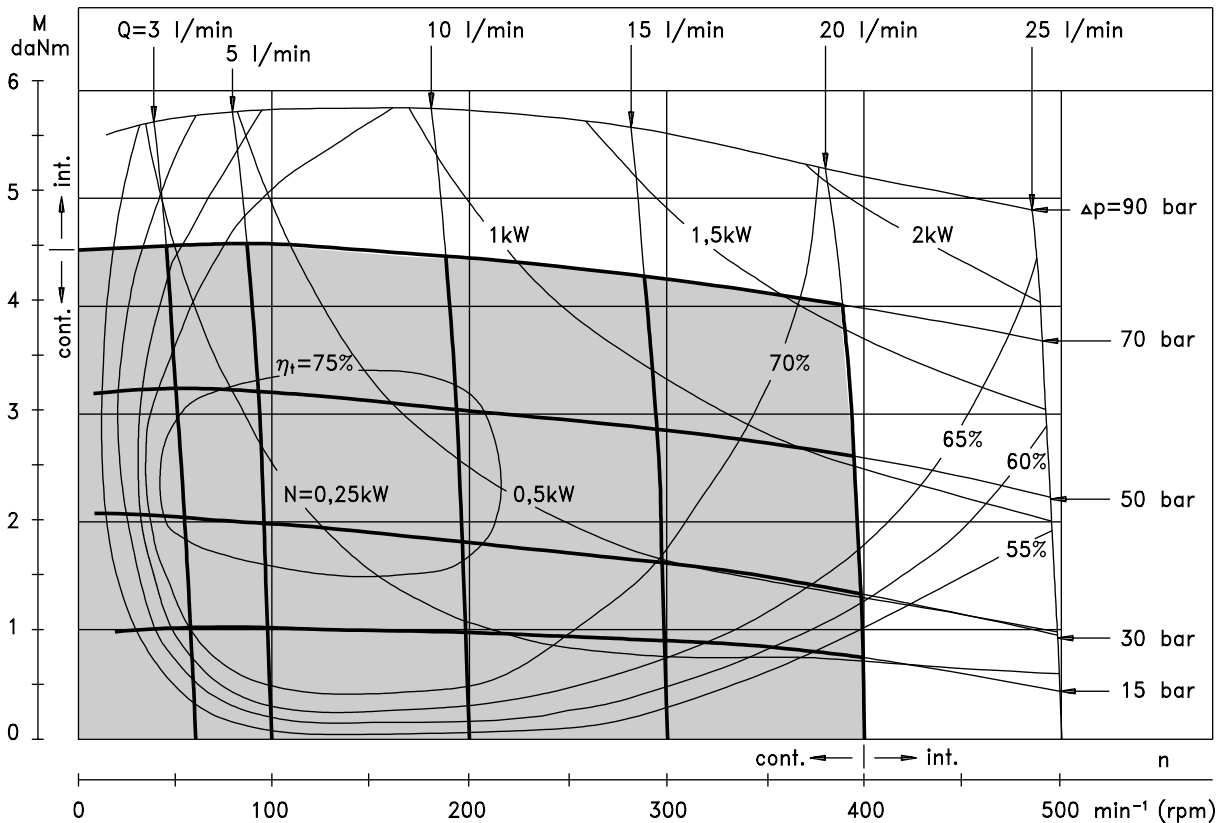

The function diagrams data was collected at back pressure 5÷10 bar and oil with viscosity of 32 mm²/s at 50° C.

DIMENSIONS AND MOUNTING DATA

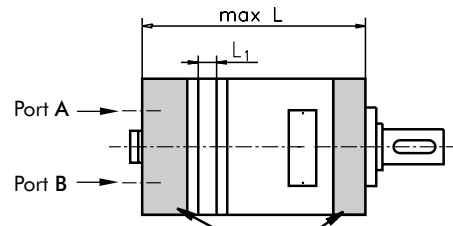

Porting

Rear Ports

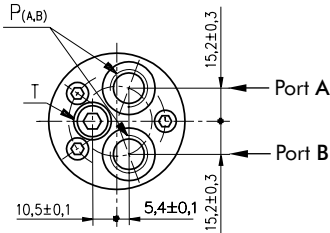

S - Side Ports

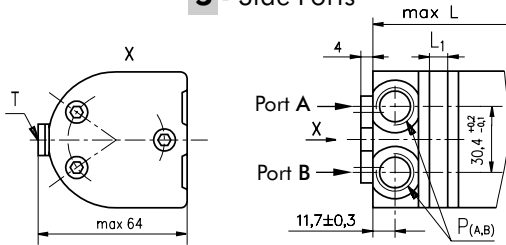

P - Side Ports with Single Crossover Relief Valve

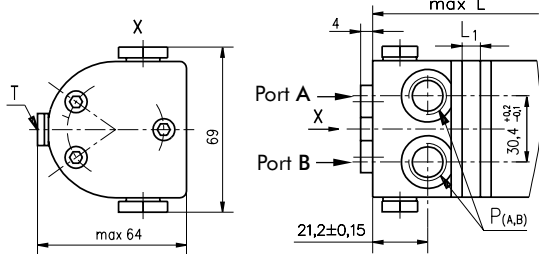

D - Side Ports with Dual Crossover Relief Valve

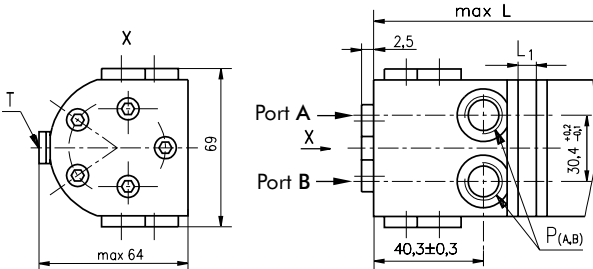

Mounting

Three Bolts Mount

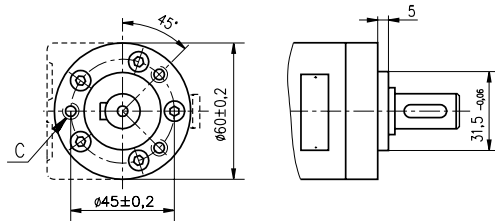

F - Oval Mount (2 Holes)

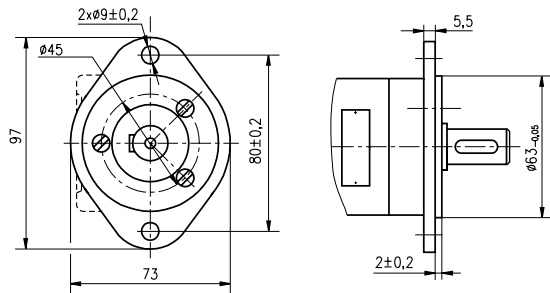

C : 3xM6- 12 mm depth

P_(A,B): 2xG3/8 or (M18x1,5)- 12 mm depth

T : G1/8 or (M10x1)- 10 mm depth

Standard Rotation
Viewed from Shaft End
Port A Pressurized - CW
Port B Pressurized - CCW

Reverse Rotation
Viewed from Shaft End
Port A Pressurized - CCW
Port B Pressurized - CW

Type	L,mm	Type	L,mm	Type	L,mm	Type	L,mm	L ₁ ,mm
MM 8	104	MMS 8	105	MMP 8	115	MMD 8	134	3,5
MM12,5	106	MMS12,5	107	MMP12,5	117	MMD12,5	136	5,5
MM 20	109	MMS 20	110	MMP 20	120	MMD 20	139	8,5
MM 32	114	MMS 32	115	MMP 32	125	MMD 32	144	13,5
MM 40	117,5	MMS 40	118,5	MMP 40	128,5	MMD 40	147,5	17
MM 50	121,5	MMS 50	122,5	MMP 50	132,5	MMD 50	151,5	21

SHAFT EXTENSIONS

C - $\varnothing 16$ straight, Parallel key 5x5x16 DIN 6885
Max. Torque 3,9 daNm

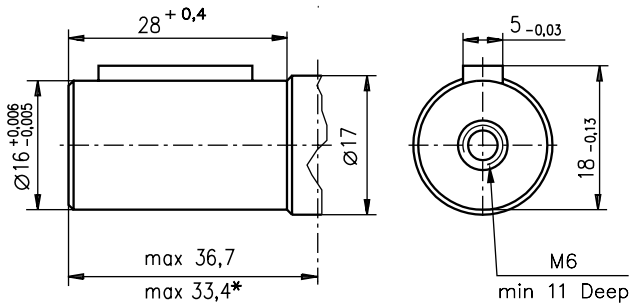

CK - $\varnothing 14$ Straight, Parallel key 5x5x16 DIN 6885
Max. Torque 3 daNm

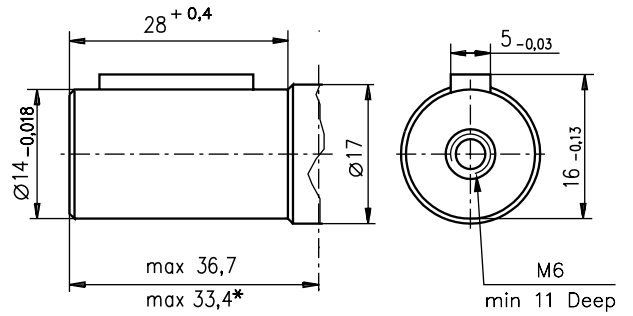

SH - $\varnothing 16,5$ Splined, B17x14 DIN 5482
Max. Torque 4,4 daNm

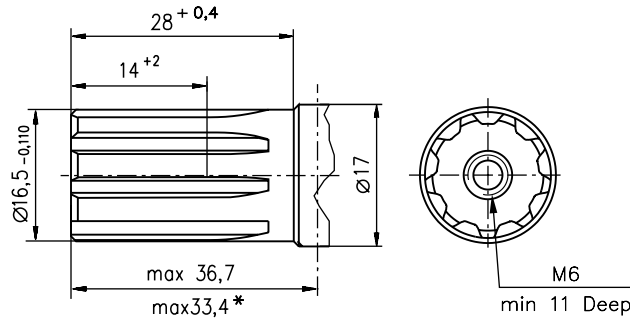

- Motor Mounting Surface
* For **F** Mounting

PERMISSIBLE SHAFT LOAD

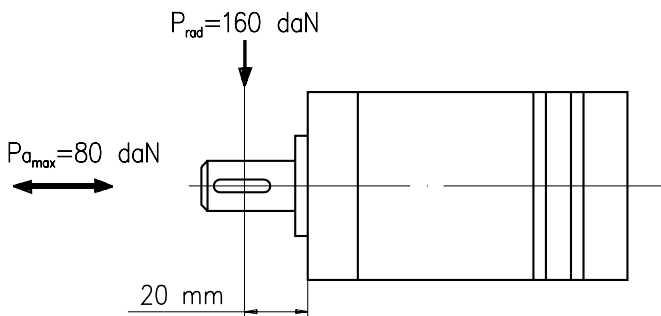

The permissible radial shaft load [P_{rad}] is calculated from the distance [L] between the point of load application and the mounting surface:

$$P_{rad} = \frac{600}{n} \times \frac{13040}{(61,5+L)}, \text{ [daN]}$$

[L in mm; L ≤ 80]

The drawing shows the permissible radial load when L=20 mm.

If the calculated shaft load exceeds the permissible, a flexible coupling must be used.

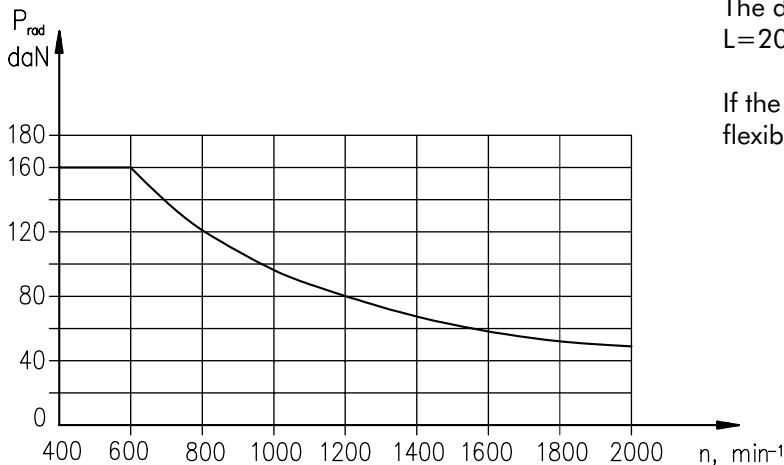

ORDER CODE

	1	2	3	4	5	6	7	8	9	10
M M										

Pos. 1 - Adjustment Option

omit - without valve

P - Side ports with single crossover relief valve

D - Side ports with dual crossover relief valve

Pos. 2 - Mounting Flange

omit - Three bolts mount

F - Oval mount, two holes

Pos. 3 - Port type (not valid for **P** and **D** version)

omit - Rear ports

S - Side ports

Pos. 4 - Displacement code

8 - 8,2 [cm³/rev]

12,5 - 12,9 [cm³/rev]

20 - 20,0 [cm³/rev]

32 - 31,8 [cm³/rev]

40 - 40,0 [cm³/rev]

50 - 50,0 [cm³/rev]

Pos. 5 - Shaft Extensions*

C - ø16 straight, Parallel key 5x5x16 DIN 6885

VC - ø16 straight, Parallel key 5x5x16 DIN 6885 with corrosion resistant bushing

CK - ø14 straight, Parallel key 5x5x16 DIN 6885

SH - ø16,5 splined, B17x14 DIN 5482

Pos. 6 - Ports

omit - BSPP (ISO 228)

M - Metric (ISO 262)

Pos. 7 - Line to controlled ** (see page 4)

/L - B→A (left running)

/R - A→B (right running)

Pos. 8 - Valve Rated Pressure ***

/50 - Δ p=50 bar

/100 - Δ p=100 bar

Pos. 9 - Special Features (see page 46)

Pos. 10 - Design Series

omit - Factory specified

NOTES:

* The permissible output torque for shafts must not be exceeded!

** For "**P**" option useful only.

*** For "**P**" and "**D**" option useful only.

The hydraulic motors are mangano-phosphatized as standard.

F - FLANGE KIT (2 Holes)

Order No: 48443 014 00

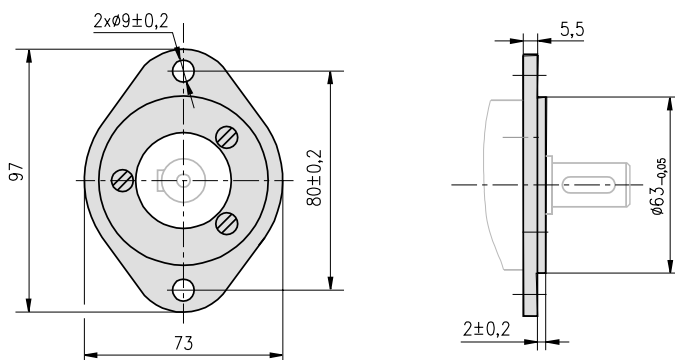

Flange Kit includes 3 screws - M6x14 for attaching flange to the motor.

HYDRAULIC MOTORS MP



APPLICATION

- » Conveyors
- » Feeding mechanism of robots and manipulators
- » Metal working machines
- » Textile machines
- » Machines for agriculture
- » Food industries
- » Grass cutting machinery etc.

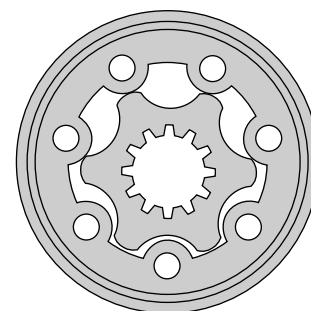

CONTENTS

Specification data13÷14
 Function diagrams15÷21
 Dimensions and mounting 22
 Wheel motor 23
 Shaft extensions 24
 Permissible shaft loads 25
 Permissible shaft Seal Pressure ... 26
 Order code 27

OPTIONS

- » Model- Spool valve, gerotor
- » Flange and wheel mount
- » Motor with needle bearing
- » Side and rear ports
- » Shafts- straight, splined and tapered
- » Shaft seal for high and low pressure
- » Metric and BSPP ports
- » Speed sensing
- » Other special features

GENERAL

Displacement,	[cm ³ /rev.]	25 ÷ 623,6
Max. Speed,	[RPM]	95 ÷ 1600
Max. Torque,	[daNm]	3,3 ÷ 50
Max. Output,	[kW]	3,3 ÷ 10,5
Max. Pressure Drop,	[bar]	55 ÷ 140
Max. Oil Flow,	[l/min]	40 ÷ 60
Min. Speed,	[RPM]	10
Pressure fluid		Mineral based- HLP(DIN 51524) or HM(ISO 6743/4)
Temperature range,	[°C]	-30 ÷ 90
Optimal Viscosity range,	[mm ² /s]	20 ÷ 75
Filtration		ISO code 20/16 (Min. recommended fluid filtration of 25 micron)

Oil flow in drain line

Pressure drop (bar)	Viscosity (mm ² /s)	Oil flow in drain line (l/min)
100	20	2,5
	35	1,8
140	20	3,5
	35	2,8

Pressure Losses

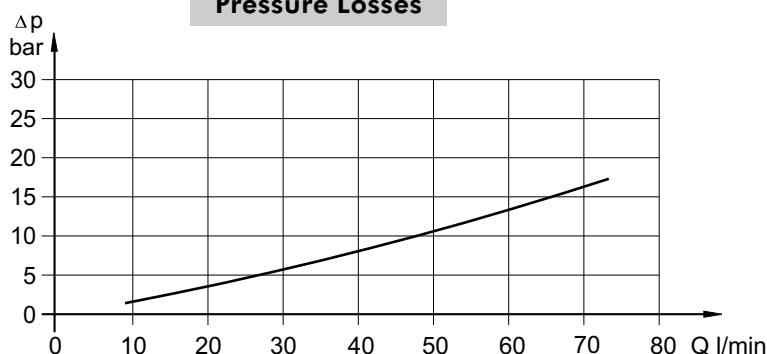

SPECIFICATION DATA

Specification Data for MP... motors with C, CO, SH, K and SA shafts.
(ø28,56 sealing diameter)

Type	MP														
	25	32	40	50	80	100	125	160	200	250	315	400	500	630	
Displacement, [cm ³ /rev.]	25	32	40	49,5	79,2	99	123,8	158,4	198	247,5	316,8	396	495	623,6	
Max. Speed, [RPM]	cont.	1600	1560	1500	1210	755	605	486	378	303	242	190	150	120	95
	int.*	1800	1720	1750	1515	945	755	605	472	378	303	236	189	150	120
Max. Torque [daNm]	cont.	3,3	4,3	6,2	9,4	15,1	19,3	23,7	31,3	36,6	38	38	36	39	44
	int.*	4,7	6,1	8,2	11,9	19,5	23,7	29,8	37,8	45,6	58,3	56	59	57	64
	peak**	6,7	8,6	10,7	14,3	22,4	27,5	36,5	43,8	55	68,5	85	85,4	78	82
Max. Output, [kW]	cont.	4,5	5,8	8,4	10,1	10,2	10,5	10	10,1	10	7,5	5,7	4,6	3,5	3,3
	int.*	6,1	7,8	11,6	12,2	12,5	12,8	12	12,1	12	12	9	7,8	7,2	5,6
Max. Pressure Drop [bar]	cont.	100	100	120	140	140	140	140	140	140	110	90	70	60	55
	int.*	140	140	155	175	175	175	175	175	175	175	140	115	90	80
	peak**	225	225	225	225	225	225	225	225	225	225	225	180	130	110
Max. Oil Flow [l/min]	cont.	40	50	60	60	60	60	60	60	60	60	60	60	60	60
	int.*	45	55	70	70	70	70	70	70	70	70	70	70	70	70
Max. Inlet Pressure [bar]	cont.	175	175	175	175	175	175	175	175	175	175	175	175	140	140
	int.*	200	200	200	200	200	200	200	200	200	200	200	200	175	175
	peak**	225	225	225	225	225	225	225	225	225	225	225	225	225	225
Max. Return Pressure with Drain Line [bar]	cont.	175	175	175	175	175	175	175	175	175	175	175	175	140	140
	int.*	200	200	200	200	200	200	200	200	200	200	200	200	175	175
	peak**	225	225	225	225	225	225	225	225	225	225	225	225	225	225
Max. Starting Pressure with Unloaded Shaft, [bar]		10	10	10	10	10	10	9	8	7	6	5	5	5	5
Min. Starting Torque [daNm]	at max. press. drop cont.	3	4	5,4	7,8	13,2	16,6	20,7	28,2	33,5	33,6	34,4	34,5	36	41,5
	at max. press. drop int.*	4,2	5,6	6,9	10	16,8	21	26,6	35,5	42,6	54,2	61,9	60,8	54	62
Min. Speed***, [RPM]		20	15	10	10	10	10	10	10	10	10	10	10	10	10
Weight, avg. [kg]	MP(F)	5,6	5,6	5,7	5,8	5,9	6,1	6,2	6,4	6,6	6,8	7,1	7,6	8,9	9,5
	MPQ(N)	5,0	5,0	5,1	5,2	5,3	5,5	5,6	5,8	6,0	6,2	6,5	6,8	8,3	9,0
	MP(F)(N)E	6,1	6,1	6,2	6,3	6,4	6,6	6,7	6,9	7,1	7,3	7,6	8,1	9,3	10
	MPW(N)	5,3	5,3	5,4	5,5	5,6	5,8	5,9	6,1	6,3	6,5	6,8	7,2	8,6	9,2
	MPQ(N)E	5,5	5,5	5,6	5,7	5,8	6,0	6,1	6,3	6,5	6,7	7,0	7,3	8,8	8,5

* Intermittent operation: the permissible values may occur for max. 10% of every minute.

** Peak load: the permissible values may occur for max. 1% of every minute.

*** For speeds of 10 RPM or lower, consult factory or your regional manager.

- Intermittent speed and intermittent pressure drop must not occur simultaneously.
- Recommended filtration is per ISO cleanliness code 20/16. A nominal filtration of 25 micron or better.
- Recommended using a premium quality, anti-wear type mineral based hydraulic oil HLP(DIN51524) or HM (ISO 6743/4).
If using synthetic fluids consult the factory for alternative seal materials.
- Recommended minimum oil viscosity 13 mm²/s at operating temperatures.
- Recommended maximum system operating temperature is 82°C.
- To assure optimum motor life fill with fluid prior to loading and run at moderate load and speed for 10-15 minutes.

SPECIFICATION DATA (continued)

Specification Data for MP... motors with CB, KB, OB and HB shafts.
($\varnothing 35$ sealing diameter)

Type	MP													
	25	32	40	50	80	100	125	160	200	250	315	400	500	630
Displacement, [cm ³ /rev.]	25	32	40	49,5	79,2	99	123,8	158,4	198	247,5	316,8	396	495	623,6
Max. Speed, [RPM]	cont.	1600	1560	1500	1210	755	605	486	378	303	242	190	150	95
	int.*	1800	1720	1750	1515	945	755	605	472	378	303	236	189	120
Max. Torque [daNm]	cont.	3,3	4,3	6,2	9,4	15,1	19,3	23,7	31,3	36,6	47	48,6	50	39
	int.*	4,7	6,1	8,2	11,9	19,5	23,7	29,8	37,8	45,6	58,3	56	59	64
	peak**	6,7	8,6	10,7	14,3	22,4	27,5	36,5	43,8	55	68,5	85	85,4	78
Max. Output, [kW]	cont.	4,5	5,8	8,4	10,1	10,2	10,5	10	10,1	9,5	9,5	7,6	6,2	3,5
	int.*	6,1	7,8	11,6	12,2	12,5	12,8	12	12,1	12,5	12	9	7,8	7,2
Max. Pressure Drop [bar]	cont.	100	100	120	140	140	140	140	140	140	140	120	95	60
	int.*	140	140	155	175	175	175	175	175	175	175	140	115	90
	peak**	225	225	225	225	225	225	225	225	225	225	225	180	130
Max. Oil Flow [l/min]	cont.	40	50	60	60	60	60	60	60	60	60	60	60	60
	int.*	45	55	70	70	70	70	70	70	70	70	70	70	70
Max. Inlet Pressure [bar]	cont.	175	175	175	175	175	175	175	175	175	175	175	140	140
	int.*	200	200	200	200	200	200	200	200	200	200	200	175	175
	peak**	225	225	225	225	225	225	225	225	225	225	225	225	225
Max. Return Pressure with Drain Line [bar]	cont.	175	175	175	175	175	175	175	175	175	175	175	140	140
	int.*	200	200	200	200	200	200	200	200	200	200	200	175	175
	peak**	225	225	225	225	225	225	225	225	225	225	225	225	225
Max. Starting Pressure with Unloaded Shaft, [bar]		10	10	10	10	10	10	9	8	7	6	5	5	5
Min. Starting Torque [daNm]	at max. press. drop cont.	3	4	5,4	7,8	13,2	16,6	20,7	28,2	33,5	42,8	45,8	46,8	36
	at max. press. drop int.*	4,2	5,6	6,9	10	16,8	21	26,6	35,5	42,6	54,2	61,9	60,8	54
Min. Speed***, [RPM]		20	15	10	10	10	10	10	10	10	10	10	10	10
Weight, avg. [kg]	MP(F)...B	5,6	5,6	5,7	5,9	6	6,2	6,3	6,5	6,7	6,9	7,2	7,7	9
	MP(F)E...B	6,1	6,1	6,2	6,4	6,5	6,7	6,8	6,9	7,2	7,4	7,7	8,2	10,1

* Intermittent operation: the permissible values may occur for max. 10% of every minute.

** Peak load: the permissible values may occur for max. 1% of every minute.

*** For speeds of 10 RPM or lower, consult factory or your regional manager.

1. Intermittent speed and intermittent pressure drop must not occur simultaneously.
2. Recommended filtration is per ISO cleanliness code 20/16. A nominal filtration of 25 micron or better.
3. Recommended using a premium quality, anti-wear type mineral based hydraulic oil HLP(DIN51524) or HM (ISO 6743/4).
If using synthetic fluids consult the factory for alternative seal materials.
4. Recommended minimum oil viscosity 13 mm²/s at operating temperatures.
5. Recommended maximum system operating temperature is 82°C.
6. To assure optimum motor life fill with fluid prior to loading and run at moderate load and speed for 10-15 minutes.

FUNCTION DIAGRAMS

MP 25

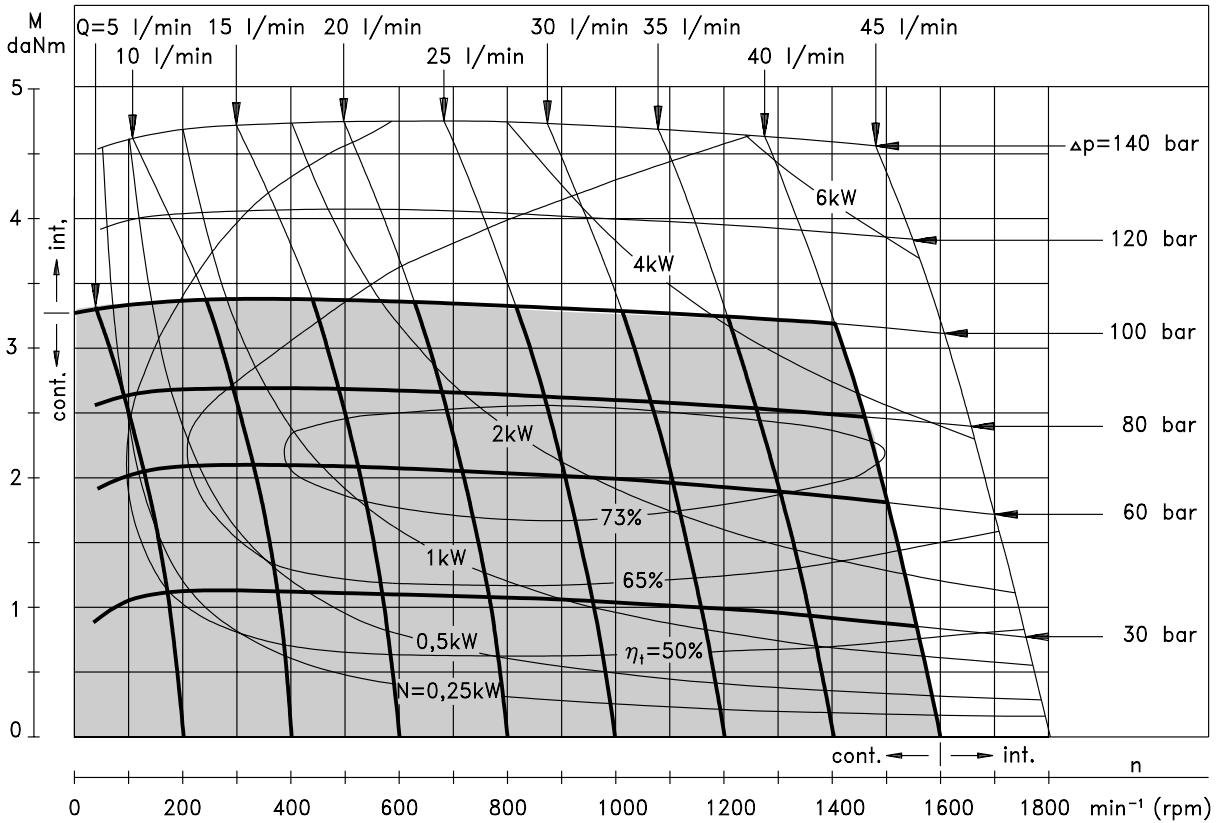

MP 32

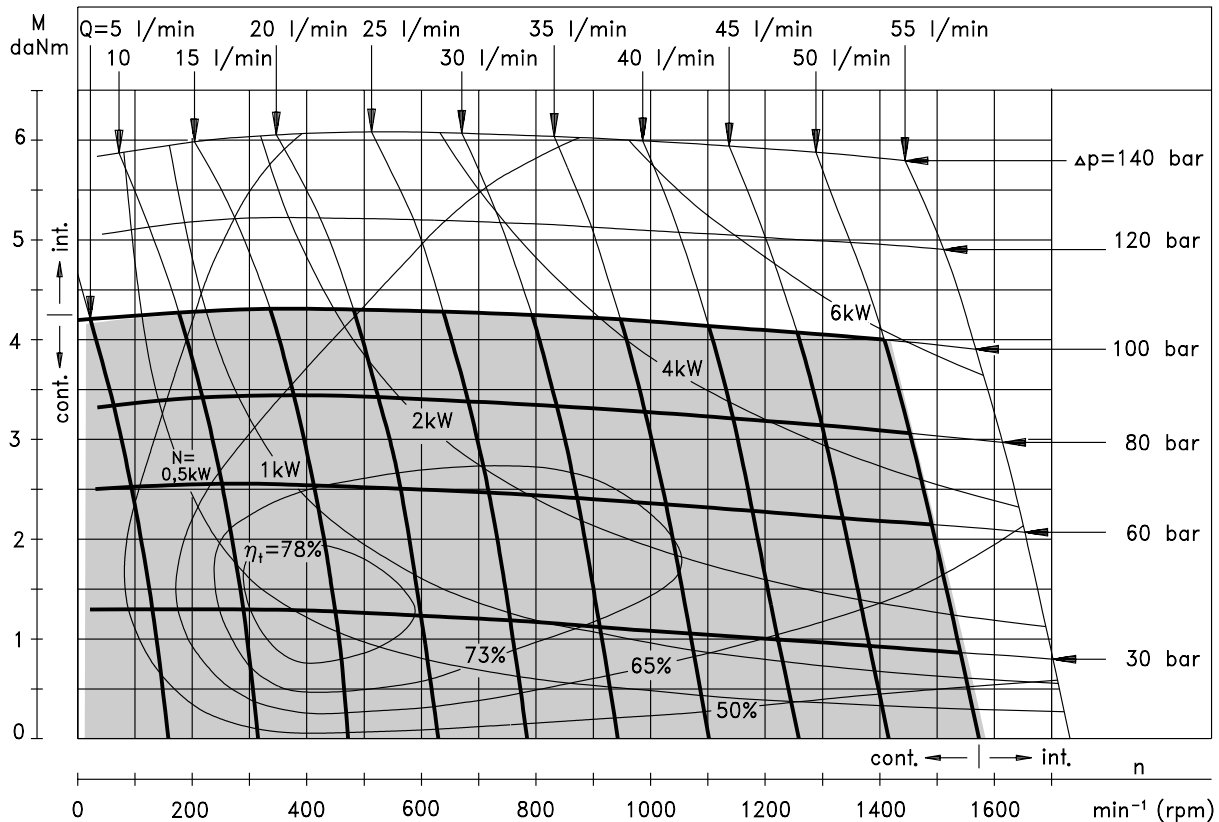

The function diagrams data was collected at back pressure 5 ÷ 10 bar and oil with viscosity of 32 mm^2/s at 50° C.

FUNCTION DIAGRAMS

MP 40

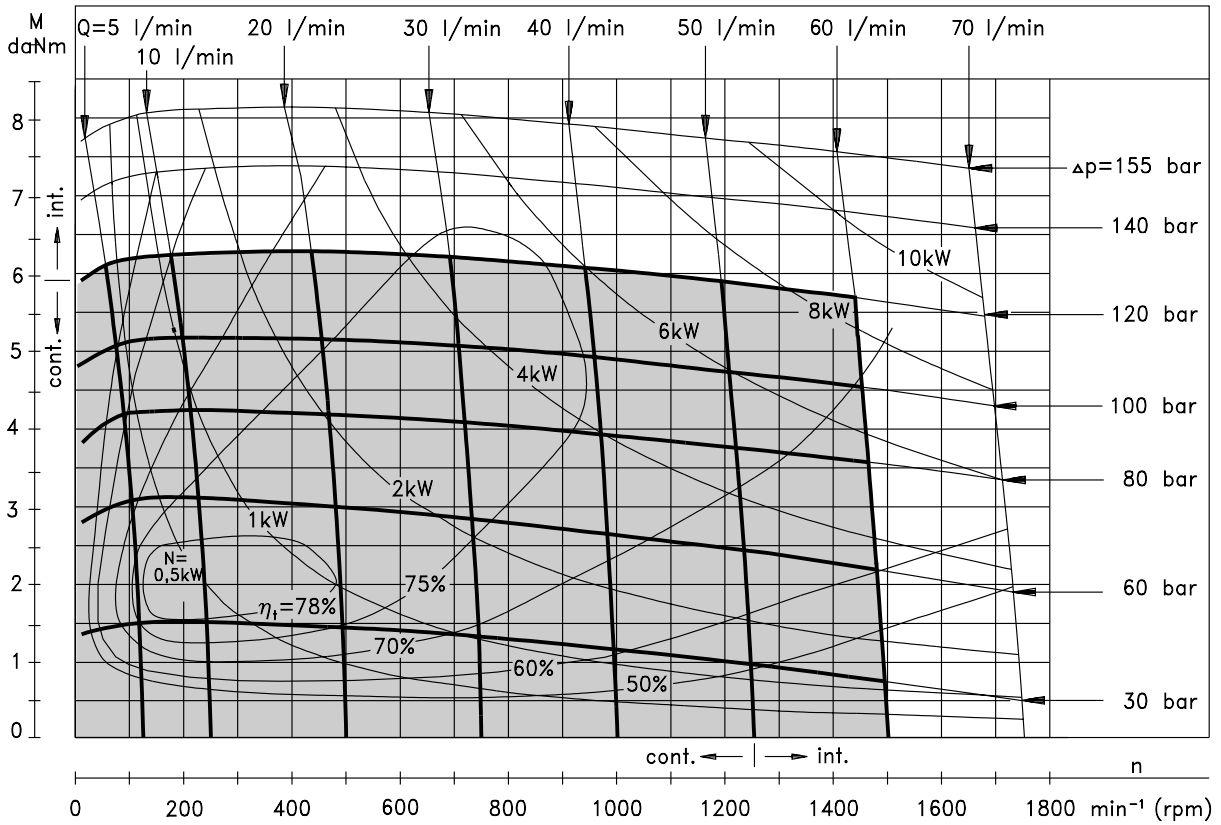

MP 50

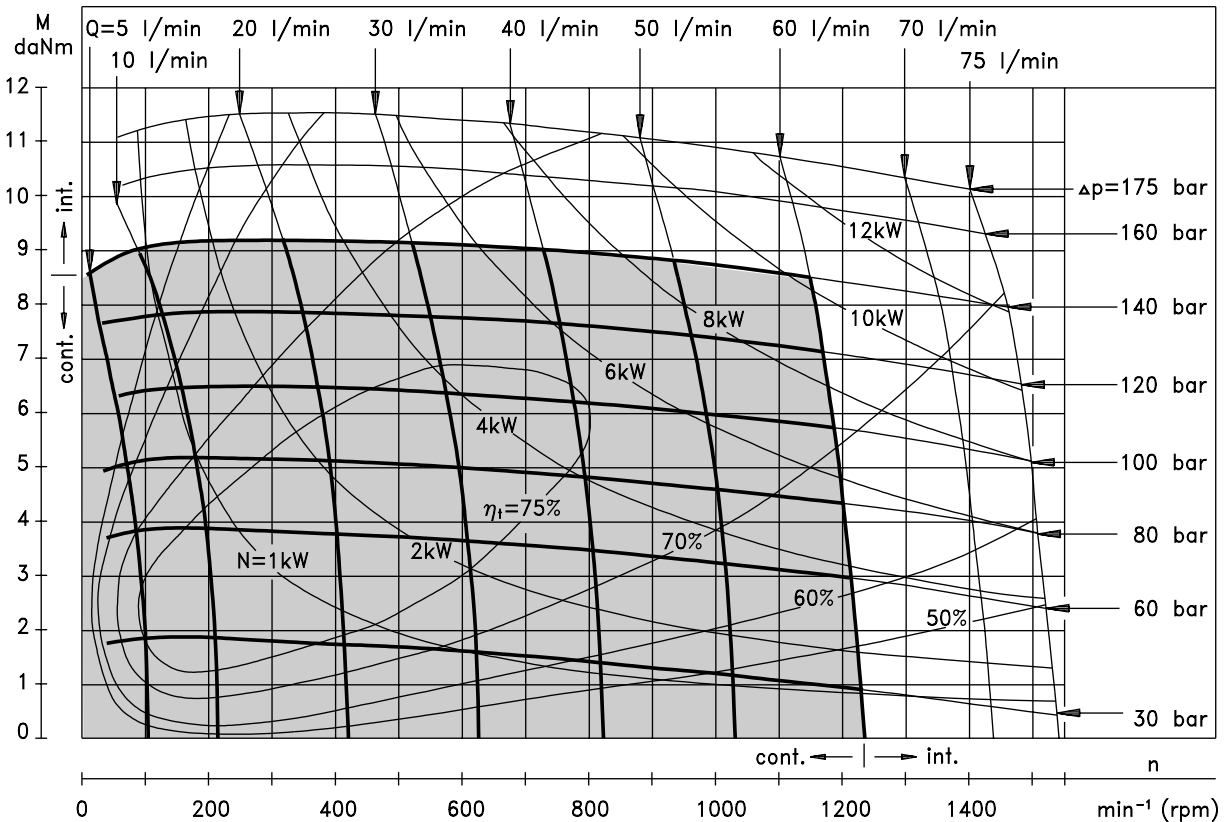

The function diagrams data was collected at back pressure 5 ÷ 10 bar and oil with viscosity of 32 mm²/s at 50° C.

FUNCTION DIAGRAMS

MP 80

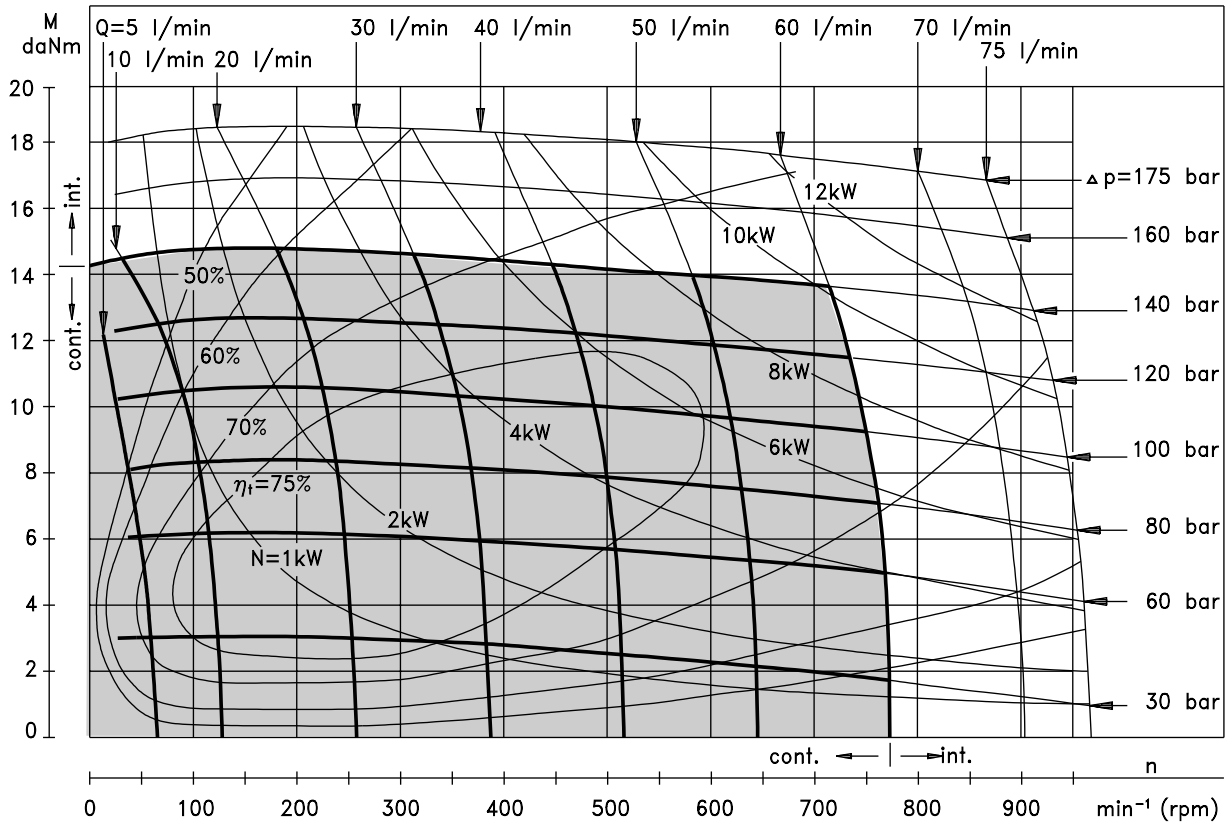

MP 100

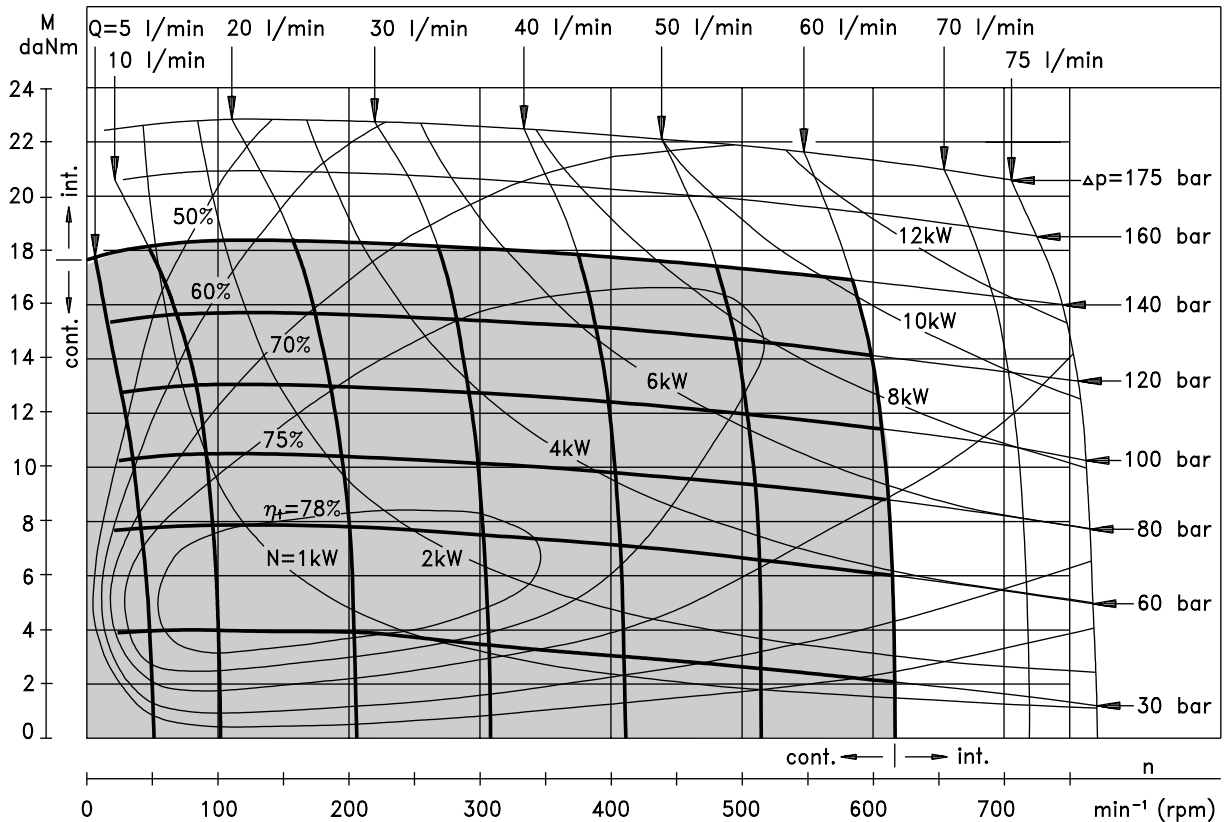

The function diagrams data was collected at back pressure 5 ÷ 10 bar and oil with viscosity of 32 mm²/s at 50° C.

FUNCTION DIAGRAMS

MP 125

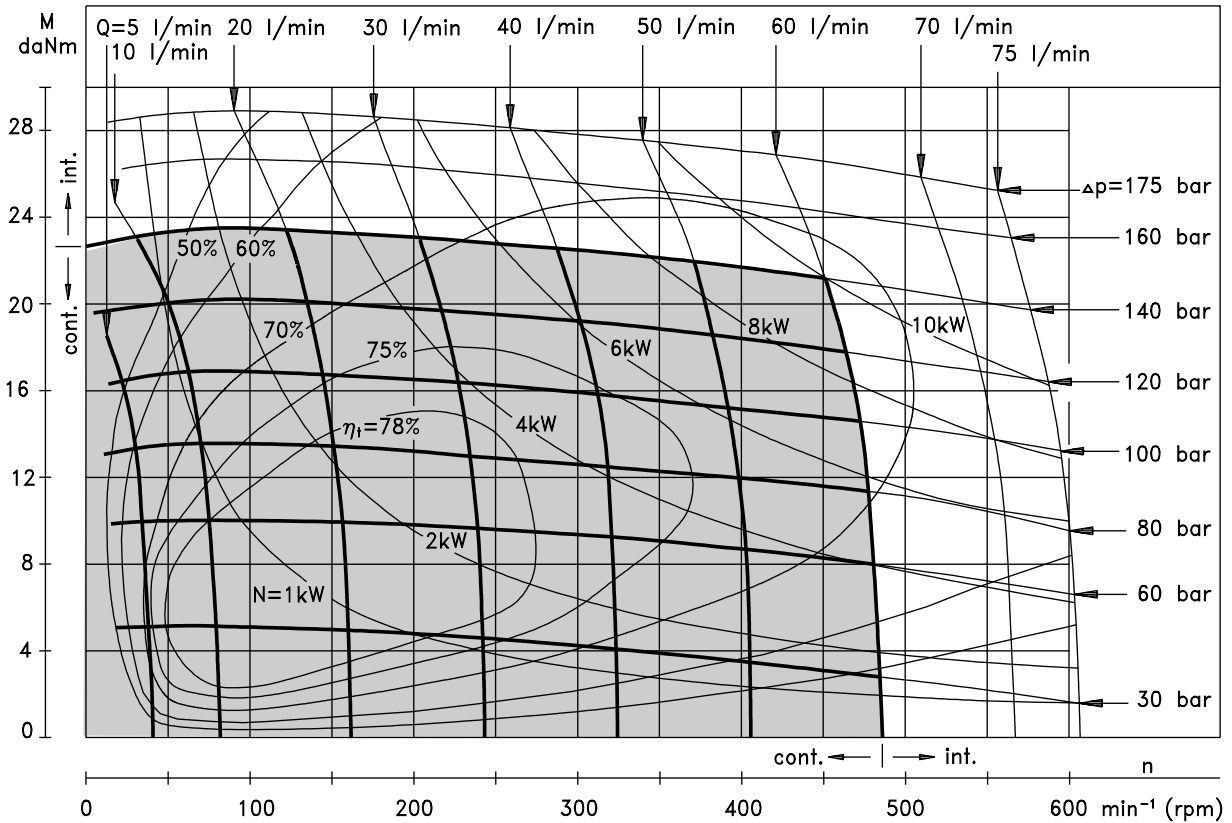

MP 160

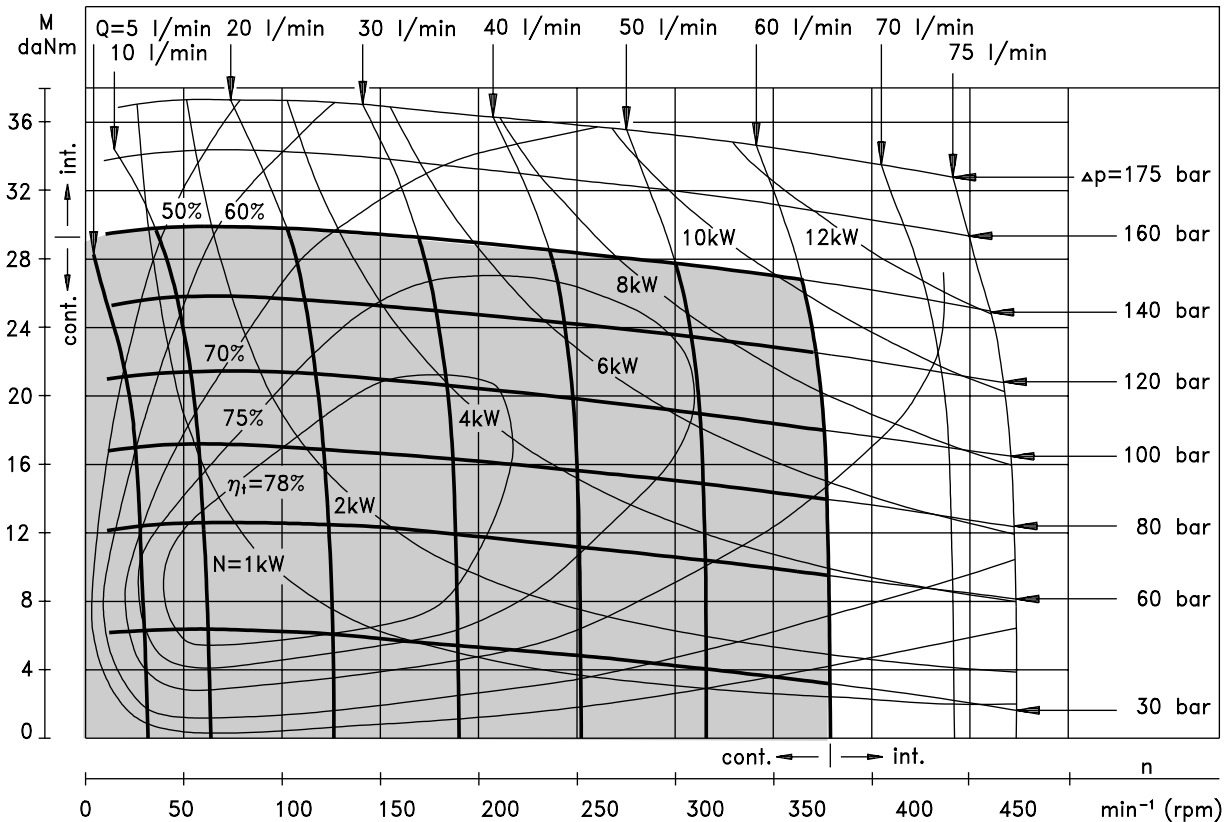

The function diagrams data was collected at back pressure 5 ÷ 10 bar and oil with viscosity of 32 mm²/s at 50° C.

FUNCTION DIAGRAMS

MP 200

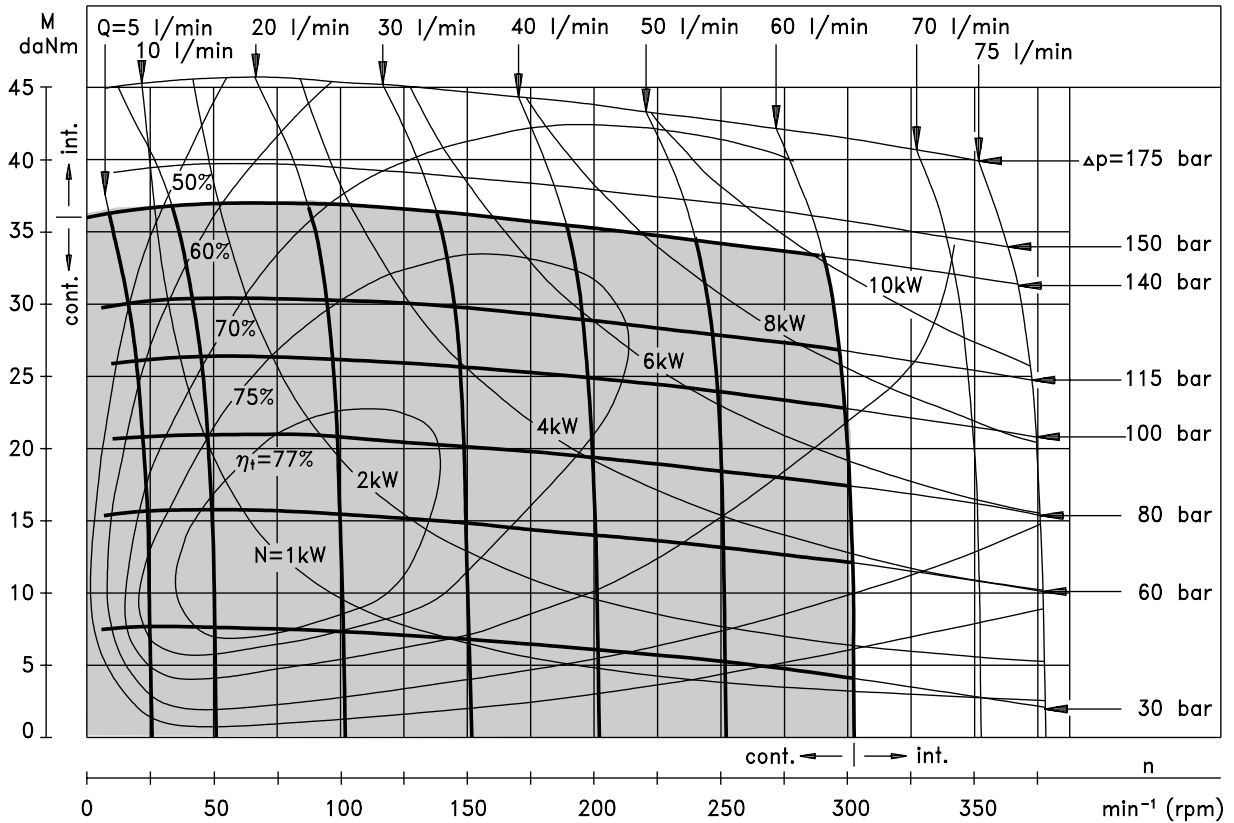

MP 250

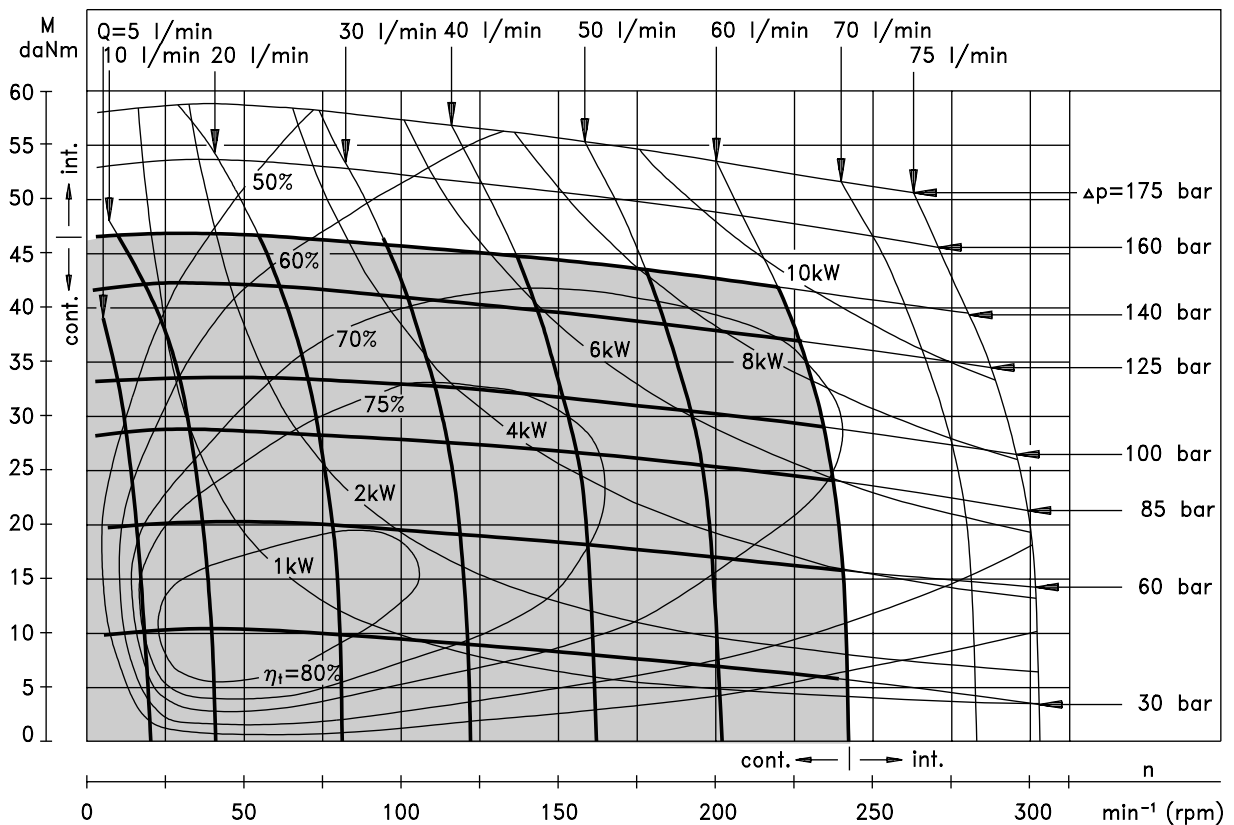

The function diagrams data was collected at back pressure 5 ÷ 10 bar and oil with viscosity of 32 mm²/s at 50° C.

FUNCTION DIAGRAM

MP 315

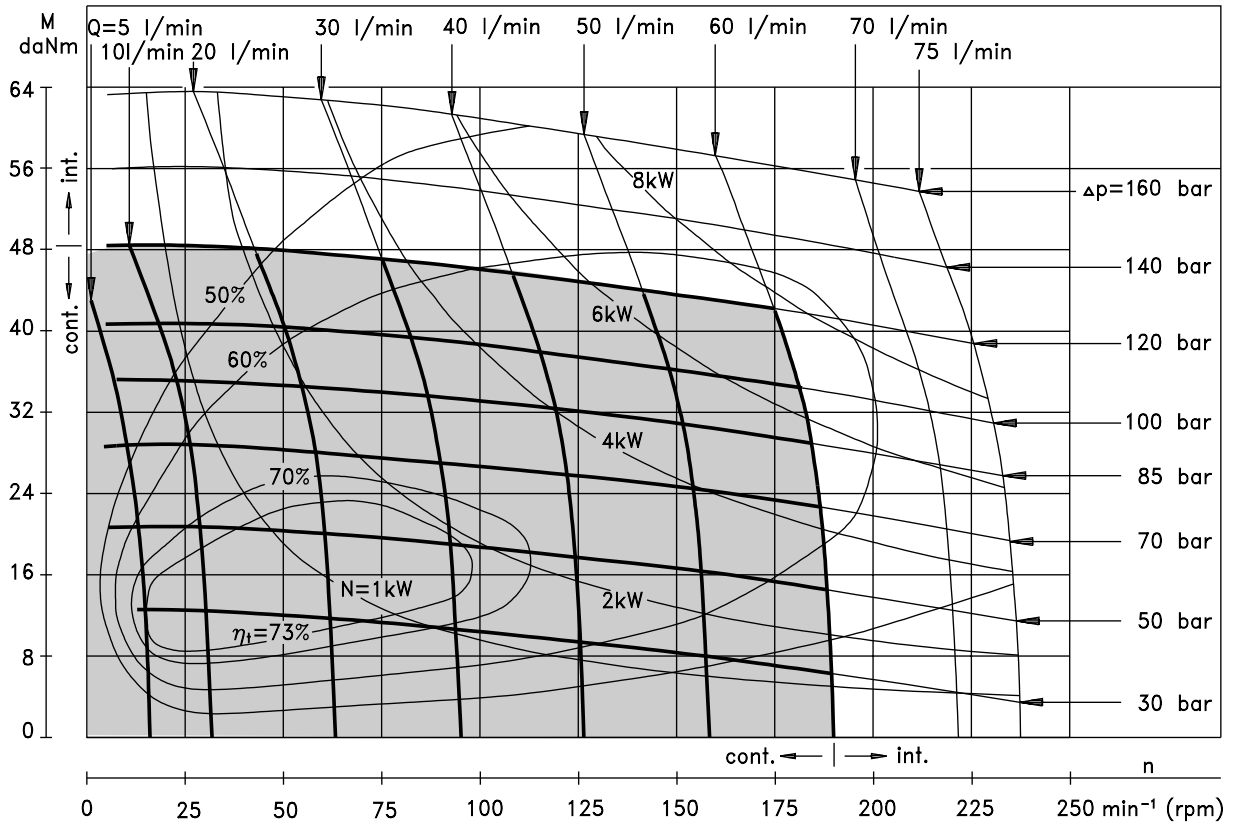

MP 400

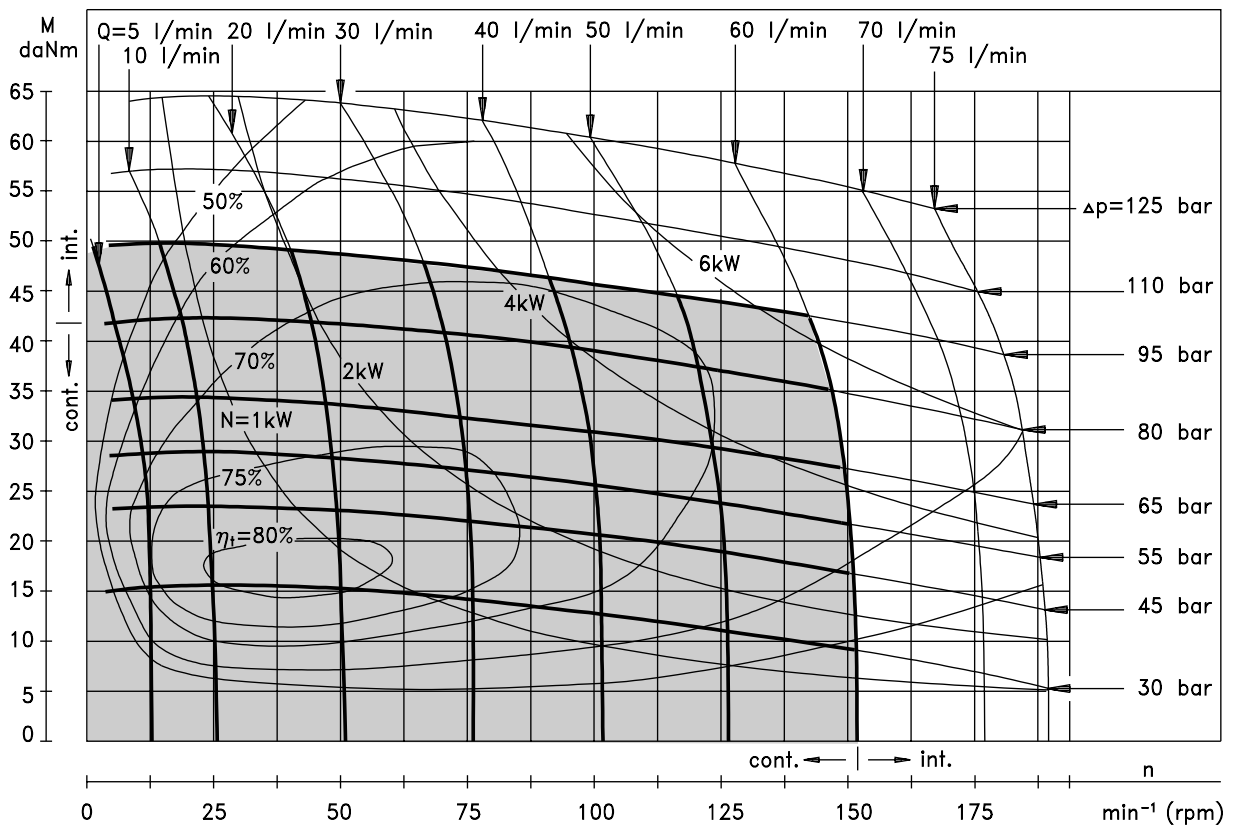

The function diagram data was collected at back pressure 5 ÷ 10 bar and oil with viscosity of 32 mm²/s at 50° C.

FUNCTION DIAGRAM

MP 500

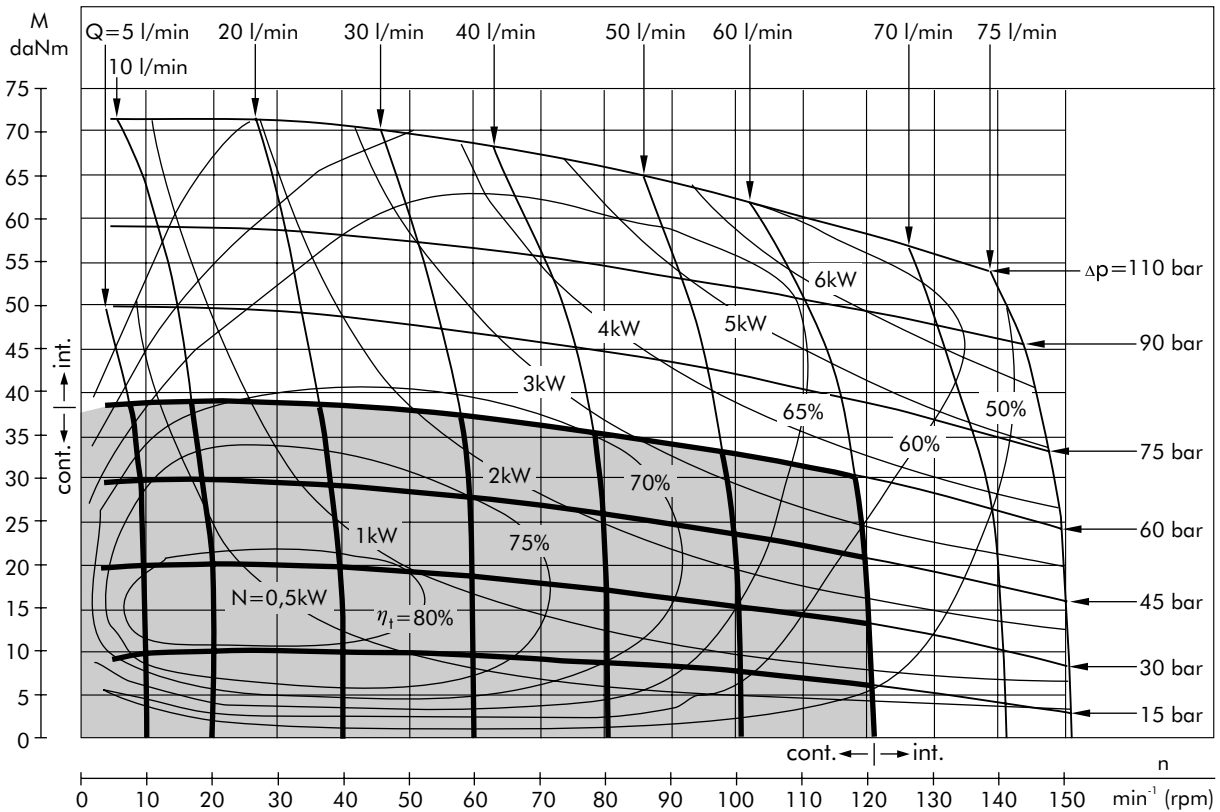

MP 630

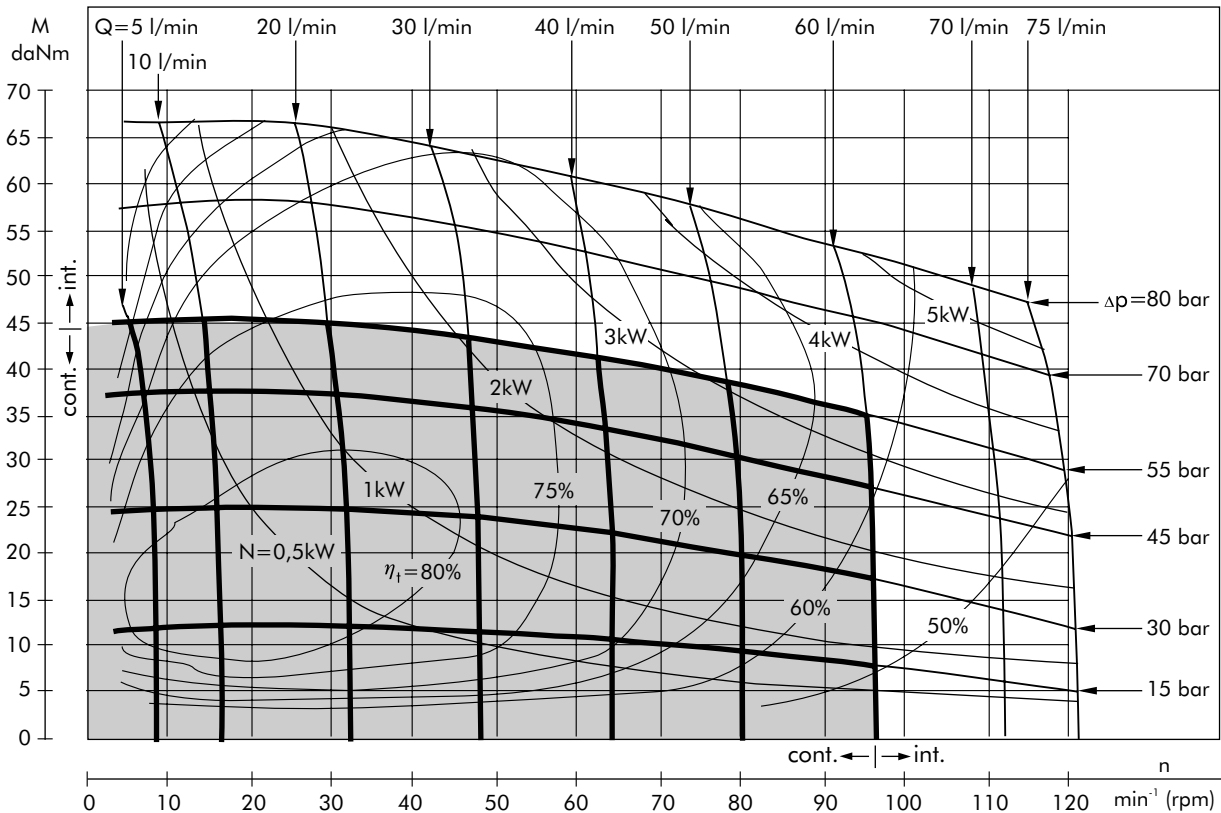

The function diagram data was collected at back pressure 5 ÷ 10 bar and oil with viscosity of 32 mm²/s at 50° C.

DIMENSIONS AND MOUNTING DATA

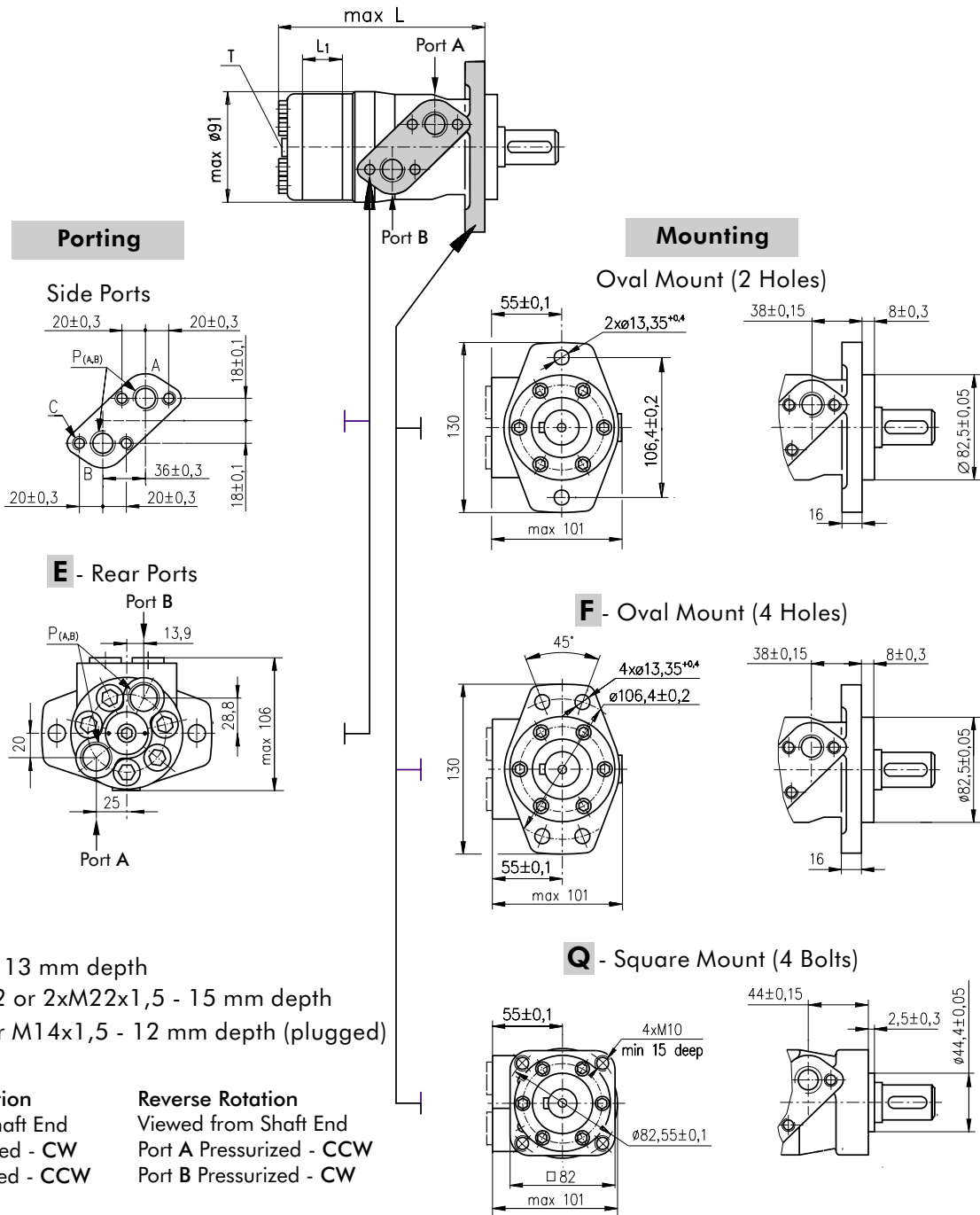

Type	L, mm	Type	L, mm	Type	L, mm	Type	L, mm	L ₁ , mm
MP(F) 25	133,2	MPQ 25	139,4	MP(F)E 25	151,2	MPQE 25	157,4	5,20
MP(F) 32	134,5	MPQ 32	140,7	MP(F)E 32	152,5	MPQE 32	158,7	6,30
MP(F) 40	135,2	MPQ 40	141,4	MP(F)E 40	153,2	MPQE 40	159,4	7,40
MP(F) 50	135,6	MPQ 50	141,8	MP(F)E 50	155,8	MPQE 50	162,0	6,67
MP(F) 80	139,6	MPQ 80	145,8	MP(F)E 80	159,8	MPQE 80	166,0	10,67
MP(F) 100	142,2	MPQ 100	148,4	MP(F)E 100	162,4	MPQE 100	168,6	13,33
MP(F) 125	145,6	MPQ 125	151,8	MP(F)E 125	165,8	MPQE 125	172,0	16,67
MP(F) 160	150,2	MPQ 160	156,4	MP(F)E 160	170,4	MPQE 160	176,6	21,33
MP(F) 200	155,6	MPQ 200	161,8	MP(F)E 200	175,8	MPQE 200	182,0	26,67
MP(F) 250	162,2	MPQ 250	168,4	MP(F)E 250	182,4	MPQE 250	188,6	33,33
MP(F) 315	171,6	MPQ 315	177,8	MP(F)E 315	191,8	MPQE 315	198,0	42,67
MP(F) 400	182,2	MPQ 400	188,4	MP(F)E 400	202,4	MPQE 400	208,6	53,33
MP(F) 500	193,0	MPQ 500	199,0	MP(F)E 500	213,0	MPQE 500	219,0	66,63
MP(F) 630	210,5	MPQ 630	216,5	MP(F)E 630	230,5	MPQE 630	236,5	84,00

DIMENSIONS AND MOUNTING DATA - MPW

W - Wheel Mount

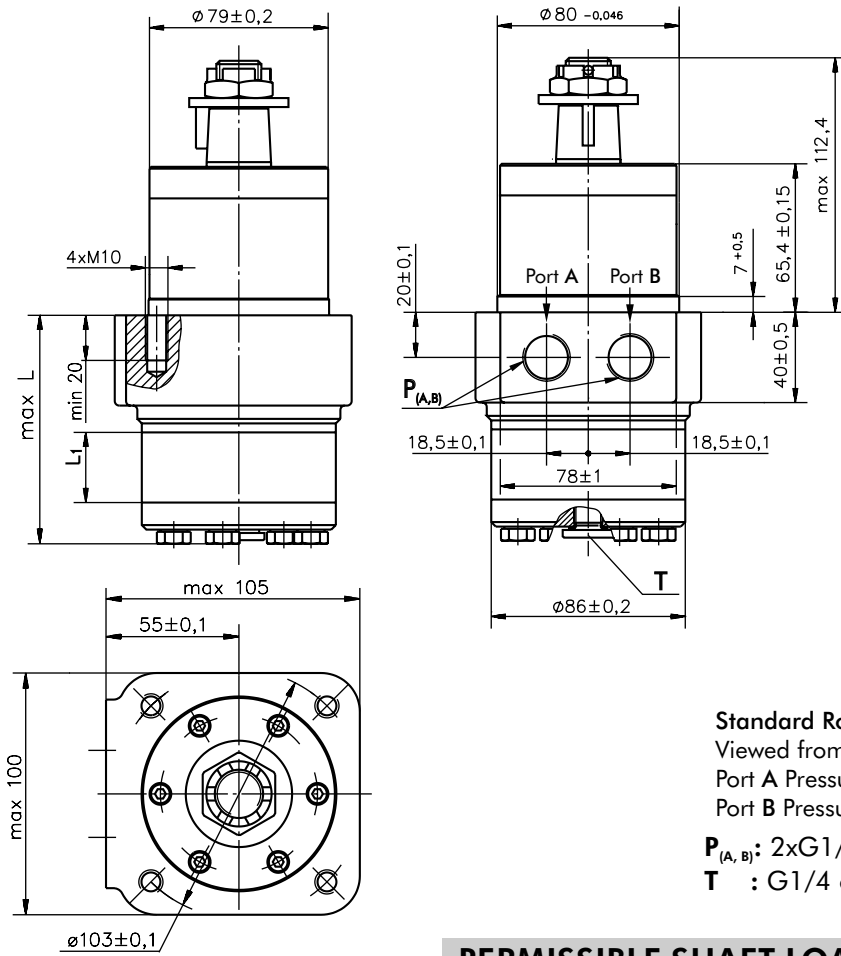

Type	L, mm	L ₁ , mm
MPW(N) 25	77,0	5,2
MPW(N) 32	78,0	6,3
MPW(N) 40	79,5	7,4
MPW(N) 50	78,5	6,67
MPW(N) 80	82,5	10,67
MPW(N) 100	85,0	13,33
MPW(N) 125	88,5	16,67
MPW(N) 160	93,0	21,33
MPW(N) 200	98,5	26,67
MPW(N) 250	105,0	33,33
MPW(N) 315	114,5	42,67
MPW(N) 400	125,0	53,33
MPW(N) 500	138,5	66,63
MPW(N) 630	156,0	84,0

Standard Rotation

Viewed from Shaft End
 Port A Pressurized - CW
 Port B Pressurized - CCW

Reverse Rotation

Viewed from Shaft End
 Port A Pressurized - CCW
 Port B Pressurized - CW

P_(A,B): 2xG1/2 or 2xM22x1,5 - 15 mm depth

T : G1/4 or M14x1,5 - 12 mm depth (plugged)

PERMISSIBLE SHAFT LOADS

MPWN

MPW

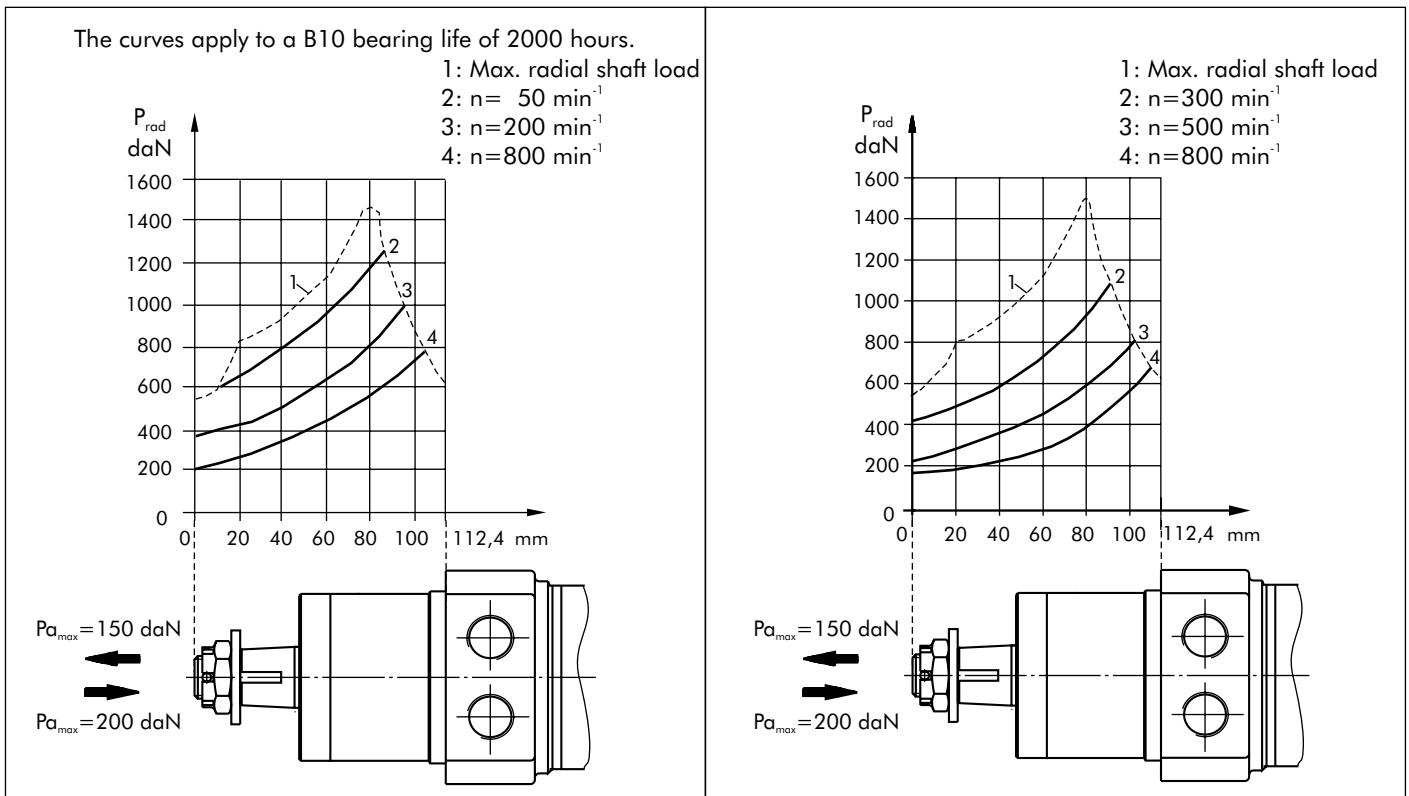

SHAFT EXTENSIONS FOR MP AND MR MOTORS

C - $\varnothing 25$ straight, Parallel key A8x7x32 DIN 6885
Max. Torque 34 daNm

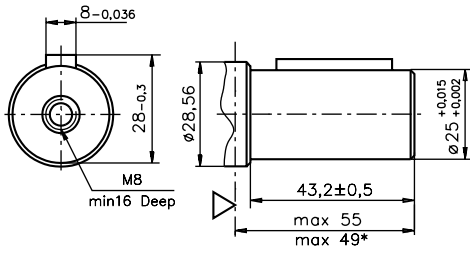

CB - $\varnothing 32$ straight, Parallel key A10x8x45 DIN 6885
Max. Torque 77 daNm

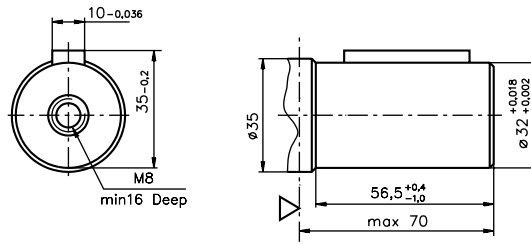

CO - $\varnothing 1"$ straight, Parallel key $\frac{1}{4} \times \frac{1}{4} \times 1 \frac{1}{4}$ " BS46
Max. Torque 34 daNm

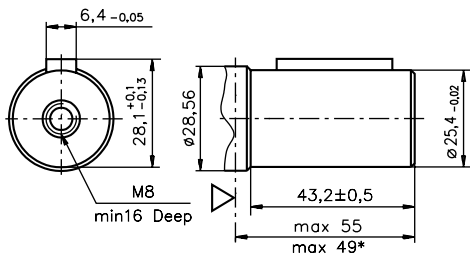

SB - splined A25x22xH10 DIN 5482
Max. Torque 34 daNm

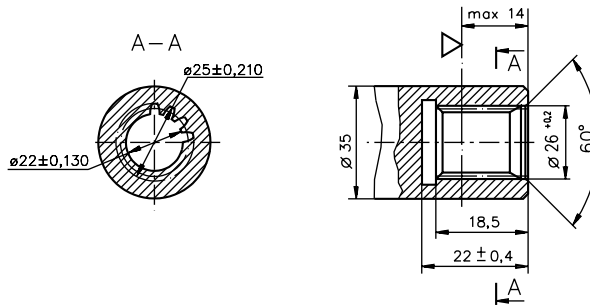

SH - splined, BS 2059 (SAE 6B)
Max. Torque 40 daNm

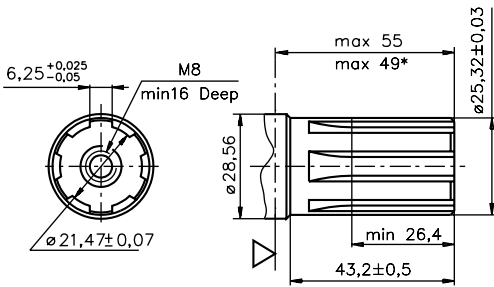

KB - tapered 1:10, Parallel key B6x6x20 DIN 6885
Max. Torque 77 daNm

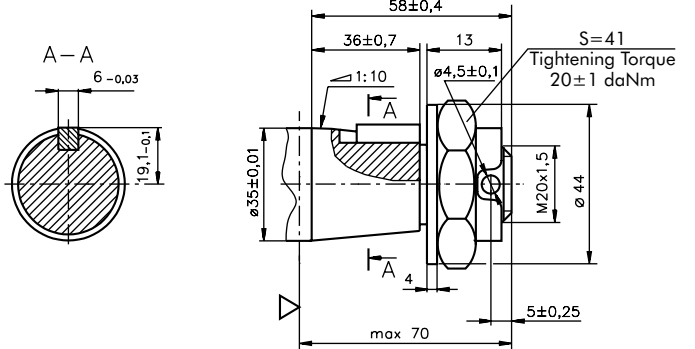

K - tapered 1:10, Parallel key B5x5x14 DIN 6885
Max. Torque 40 daNm

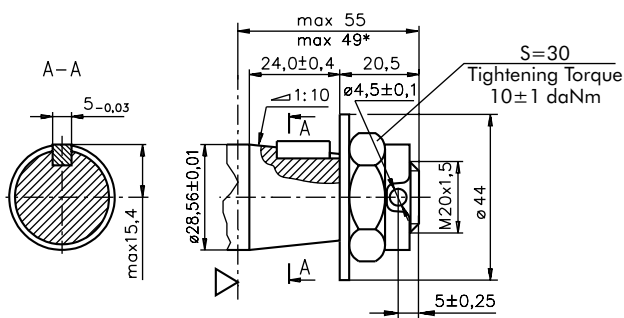

OB - tapered 1:8 SAEJ 501, Parallel key $\frac{5}{16} \times \frac{5}{16} \times 1 \frac{1}{4}$ " BS46
Max. Torque 77 daNm

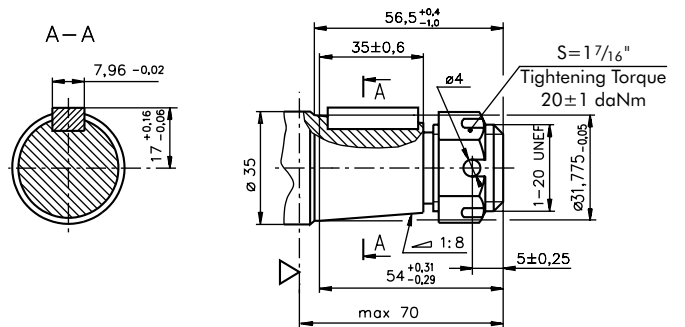

SA - splined, B25x22h9 DIN 5482
Max. Torque 40 daNm

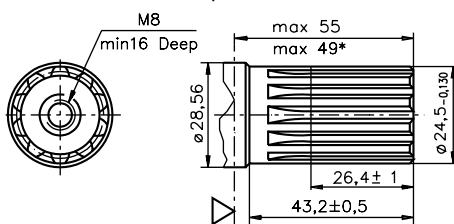

HB - $\varnothing 1 \frac{1}{4}$ " splined 14T, ANSI B92.1-1976 Norm
Max. Torque 77 daNm

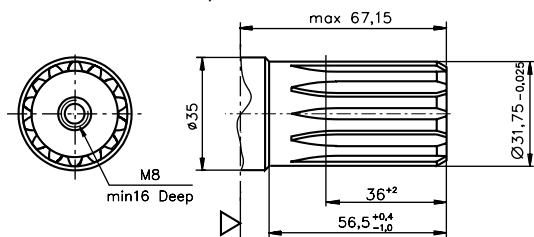

▽ - Motor Mounting Surface

* - For Q-flange

PERMISSIBLE SHAFT LOADS FOR MP AND MR MOTORS

The permissible radial shaft load P_{rad} depends on the speed (RPM) and distance (L) from the point of load to the mounting flange.

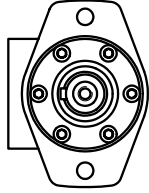
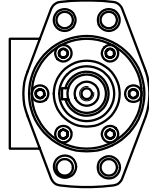
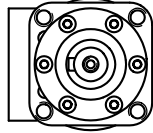
Mounting Flange			
Shaft Version	cylindrical - C, CO tapered - K, splined - SH	splined - HB cylindrical - CB	cylindrical - C, CO
Radial Shaft Load P_{rad}^*	$\frac{800}{n} \times \frac{25000}{95+L}$, daN	$\frac{800}{n} \times \frac{18750}{95+L}$, daN	$\frac{800}{n} \times \frac{25000}{101+L}$, daN

$n < 200 \text{ min}^{-1}$; max $P_{rad} = 800 \text{ daN}$

* $n \geq 200 \text{ min}^{-1}$; $L < 55 \text{ mm}$

MPN and MRN

MP and MR

The curves apply to a B10 bearing life of 2000 hours.

- 1: Max. radial shaft load
- 2: $n = 50 \text{ min}^{-1}$
- 3: $n = 200 \text{ min}^{-1}$
- 4: $n = 800 \text{ min}^{-1}$

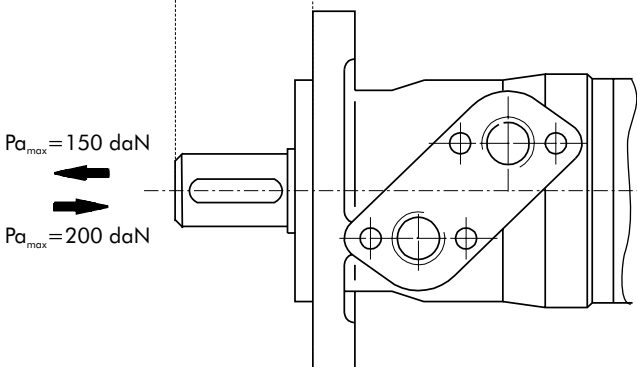
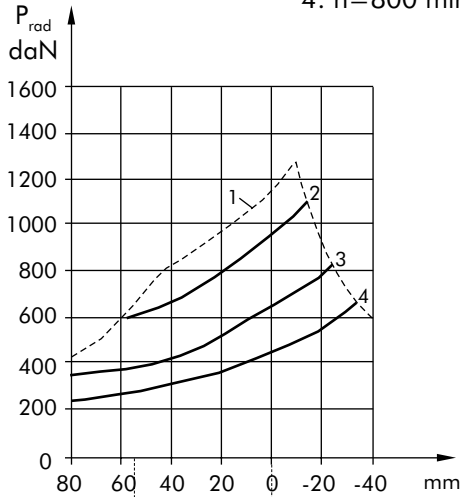

Radial Shaft Load P_{rad} for C, CO Shaft Extensions by $L = 30 \text{ (24) mm}$

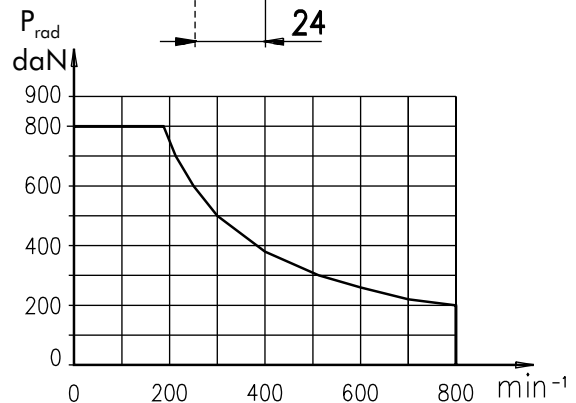
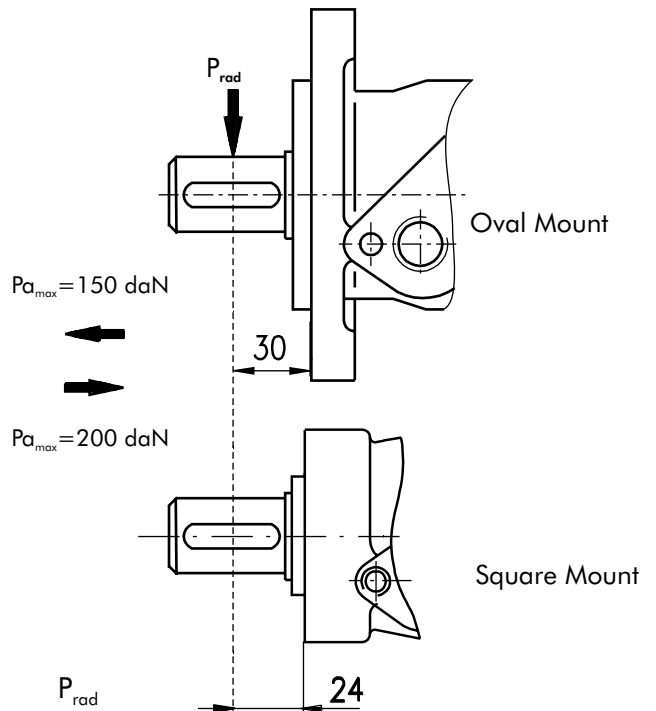

MAX. PERMISSIBLE SHAFT SEAL PRESSURE FOR MP AND MR MOTORS

MP/MR...U1 motors with high pressure seal and without drain connection:

The shaft seal pressure equals the average of input pressure and return pressure.

$$P_{\text{seal}} = \frac{P_{\text{input}} + P_{\text{return}}}{2}$$

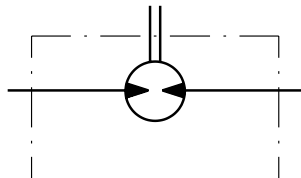

MP/MR...U motors with high pressure seal and drain connection:

The shaft seal pressure equals the pressure in the drain line.

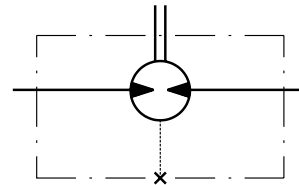

MP/MR...1 motors with low pressure seal or standard shaft seal and without drain connection:

The shaft seal pressure never exceeds the pressure in the return line.

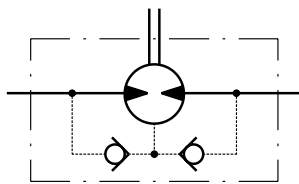

MP/MR... motors with low pressure seal or standard shaft seal and with drain connection:

The shaft seal pressure equals the pressure in the drain line.

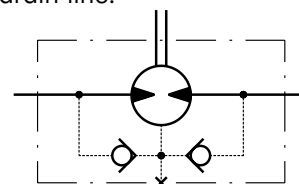

Max. return pressure without drain line or max. pressure in the drain line

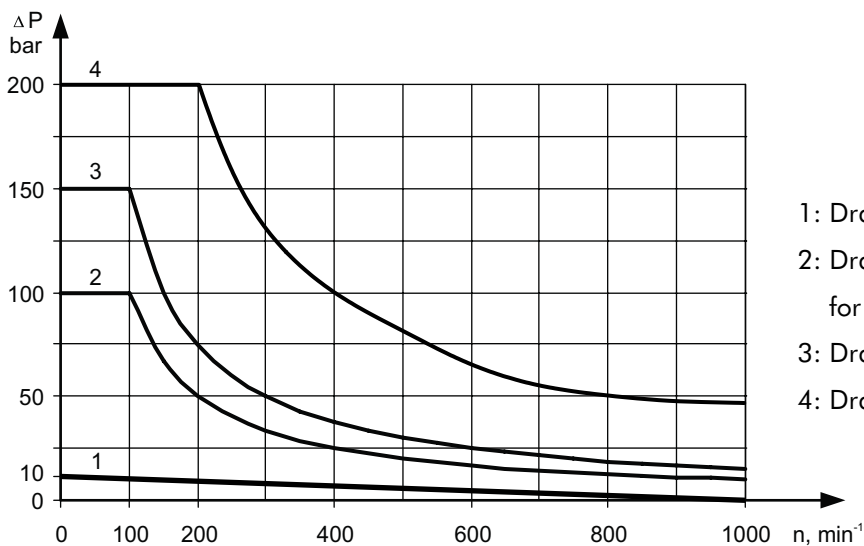

- 1: Drawing for Low Pressure Seal
- 2: Drawing for Standard Shaft Seal for "...B" shafts
- 3: Drawing for Standard Shaft Seal ("D" Seal)
- 4: Drawing for High Pressure Seal ("U" Seal)

ORDER CODE

	1	2	3	4	5	6	7	8	9	10
M P										

Pos.1 - Mounting Flange

omit - Oval mount, two holes

F - Oval mount, four holes

Q - Square mount, four bolts

W - Wheel mount

Pos.2 - Option (needle bearings)

omit - none

N - with needle bearings

Pos.3 - Port type

omit - Side ports

E - Rear ports

Pos.4 - Displacement code

25* - 25,0 [cm³/rev]

32* - 32,0 [cm³/rev]

40* - 40,0 [cm³/rev]

50 - 49,5 [cm³/rev]

80 - 79,2 [cm³/rev]

100 - 99,0 [cm³/rev]

125 - 123,8 [cm³/rev]

160 - 158,4 [cm³/rev]

200 - 198,0 [cm³/rev]

250 - 247,5 [cm³/rev]

315 - 316,8 [cm³/rev]

400 - 396,0 [cm³/rev]

500 - 495,0 [cm³/rev]

630 - 623,6 [cm³/rev]

Pos.5 - Shaft Extensions** (see page 24)

C - ø25 straight, Parallel key A8x7x32 DIN6885

VC - ø25 straight, Parallel key A8x7x32 DIN6885 with corrosion resistant bushing

CO - ø1" straight, Parallel key ¼"x¼"x1¼" BS46

VCO - ø1" straight, Parallel key ¼"x¼"x1¼" BS46 with corrosion resistant bushing

SH - ø25,32 splined BS 2059 (SAE 6B)

VSH - ø25,32 splined BS 2059 (SAE 6B) with corrosion resistant bushing

K - ø28,56 tapered 1:10, Parallel key B5x5x14 DIN6885

SA - ø24,5 splined B 25x22 DIN 5482

VSA - ø24,5 splined B 25x22 DIN 5482 with corrosion resistant bushing

CB - ø32 straight, Parallel key A10x8x45 DIN6885

KB - ø35 tapered 1:10, Parallel key B6x6x20 DIN6885

SB - splined A 25x22 DIN 5482

OB - ø1¼" tapered 1:8, Parallel key 5/16"x5/16"x1¼" BS46

HB - ø1¼" splined 14T ANSI B92.1 - 1976

Pos. 6 - Shaft Seal Version (see page 26)

omit - Low pressure shaft seal or Standard shaft seal for "...B" shaft

D - Standard shaft seal

U - High pressure shaft seal (without check valves)

Pos. 7 - Drain Port

omit - with drain port

1 - without drain port

Pos. 8 - Ports

omit - BSPP (ISO 228)

M - Metric (ISO 262)

Pos. 9 - Special Features (see page 46)

Pos.10 - Design Series

omit - Factory specified

* Not with Low Pressure Seal

** The permissible output torque for shafts must not be exceeded!

NOTES: The following combinations are not allowed:

- **Q** flange with "...B" shafts;
- **W** flange with "...B" shafts, **U** option or **E** rear ports;
- **N** option with "...B" shafts, Low Pressure Seal or **U** option;
- "...B" shafts with **D** and **U** shaft seals.

The hydraulic motors are manganophosphatized as standard.

HYDRAULIC MOTORS MR



APPLICATION

- » Conveyors
- » Feeding mechanism of robots and manipulators
- » Metal working machines
- » Textile machines
- » Machines for agriculture
- » Food industries
- » Grass cutting machinery etc.

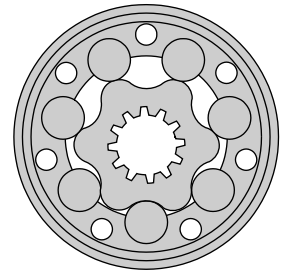

CONTENTS

Specification data29 ÷ 30
 Function diagrams31 ÷ 35
 Dimensions and mounting 36
 Shaft extensions 24
 Permissible shaft loads 25
 Permissible shaft Seal Pressure ... 26
 Order code 37

OPTIONS

- » Model- Spool valve, roll-gerotor
- » Flange mount
- » Motor with needle bearing
- » Side and rear ports
- » Shafts- straight, splined and tapered
- » Shaft seal for high and low pressure
- » Metric and BSPP ports
- » Speed sensing
- » Other special features

GENERAL

Displacement, [cm ³ /rev.]	51,5 ÷ 397
Max. Speed, [RPM]	150 ÷ 775
Max. Torque, [daNm]	10,1 ÷ 61
Max. Output, [kW]	5 ÷ 13
Max. Pressure Drop, [bar]	70 ÷ 175
Max. Oil Flow, [l/min]	40 ÷ 60
Min. Speed, [RPM]	10
Pressure fluid	Mineral based- HLP(DIN 51524) or HM(ISO 6743/4)
Temperature range, [°C]	-30 ÷ 90
Optimal Viscosity range, [mm ² /s]	20 ÷ 75
Filtration	ISO code 20/16 (Min. recommended fluid filtration of 25 micron)

Oil flow in drain line

Pressure drop (bar)	Viscosity (mm ² /s)	Oil flow in drain line (l/min)
100	20	2,5
	35	1,8
140	20	3,5
	35	2,8

Pressure Losses

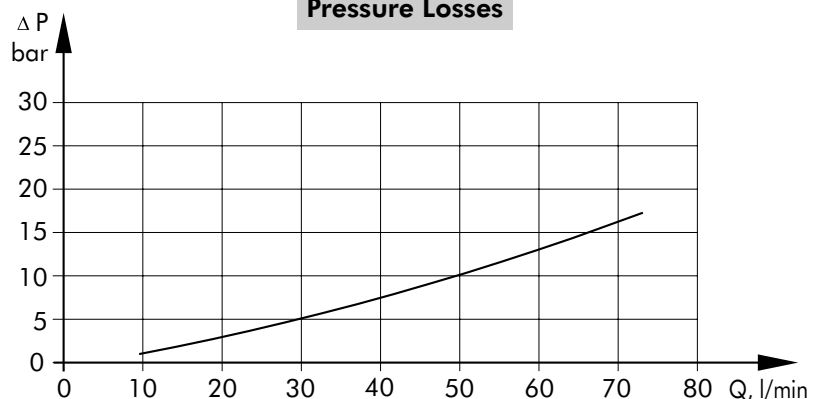

SPECIFICATION DATA

Specification Data for MR... motors with C, CO, SH, K and SA shafts.
($\varnothing 28,56$ sealing diameter)

Type	MR									
	50	80	100	125	160	200	250	315	400	
Displacement, [cm ³ /rev.]	51,5	80,3	99,8	125,7	159,6	199,8	250,1	315,7	397	
Max. Speed, [RPM]	cont.	775	750	600	475	375	300	240	190	150
	int.*	970	940	750	600	470	375	300	240	190
Max. Torque [daNm]	cont.	10	20	24	30	39	38,5	39	36	38
	int.*	13	22	28	34	43	46	47	47	47
	peak**	17	27	32	37	46	56	60	61	61
Max. Output, [kW]	cont.	7	12,5	13	12,5	11,5	9	8	5	4,8
	int.*	8,5	15	15	14,5	14	12	9,5	8	6,8
Max. Pressure Drop [bar]	cont.	140	175	175	175	175	140	110	85	65
	int.*	175	200	200	200	200	175	140	115	90
	peak**	225	225	225	225	225	225	200	150	115
Max. Oil Flow [l/min]	cont.	40	60	60	60	60	60	60	60	60
	int.*	50	75	75	75	75	75	75	75	75
Max. Inlet Pressure [bar]	cont.	175	175	175	175	175	175	175	175	175
	int.*	200	200	200	200	200	200	200	200	200
	peak**	225	225	225	225	225	225	225	225	225
Max. Return Pressure with Drain Line [bar]	cont.	175	175	175	175	175	175	175	175	175
	int.*	200	200	200	200	200	200	200	200	200
	peak**	225	225	225	225	225	225	225	225	225
Max. Starting Pressure with Unloaded Shaft, [bar]		10	10	10	9	7	5	4	3	3
Min. Starting Torque [daNm]	at max. press. drop cont.	8	15	20	25	32	33	31	31,5	31,5
	at max. press. drop int.*	10	17	23	28	37	40	48	50	50
Min. Speed***, [RPM]		10	10	10	10	10	10	10	10	10
Weight, avg. [kg] For rear ports: +0,650 kg	MR(F)	6,8	6,9	7,2	7,3	7,5	8	8,4	9,1	9,8
	MRQ(N)	6,2	6,3	6,6	6,8	7,0	7,2	7,8	8,6	9,3

* Intermittent operation: the permissible values may occur for max. 10% of every minute.

** Peak load: the permissible values may occur for max. 1% for every minute.

*** For speeds of 10 RPM or lower, consult factory or your regional manager.

1. Intermittent speed and intermittent pressure drop must not occur simultaneously!
2. Recommended filtration is per ISO cleanliness code 20/16. A nominal filtration of 25 micron or better.
3. Recommended using a premium quality, anti-wear type mineral based hydraulic oil HLP(DIN51524) or HM (ISO 6743/4).
If using synthetic fluids consult the factory for alternative seal materials.
4. Recommended minimum oil viscosity 13 mm²/s at operating temperatures.
5. Recommended maximum system operating temperature - 82°C.
6. To assure optimum motor life fill with fluid prior to loading and run at moderate load and speed for 10-15 min.

SPECIFICATION DATA (continued)

Specification Data for MR... motors with CB, KB, OB and HB shafts.
(ø35 sealing diameter)

Type	MR									
	50	80	100	125	160	200	250	315	400	
Displacement, [cm ³ /rev.]	51,5	80,3	99,8	125,7	159,6	199,8	250,1	315,7	397	
Max. Speed, [RPM]	cont.	775	750	600	475	375	300	240	190	150
	int.*	970	940	750	600	470	375	300	240	190
Max. Torque [daNm]	cont.	10	20	24	30	39	45	54	55	61
	int.*	13	22	28	34	43	50	61	69	69
	peak**	17	27	32	37	46	56	71	84	87
Max. Output, [kW]	cont.	7	12,5	13	12,5	11,5	11	10	9	7,8
	int.*	8,5	15	15	14,5	14	13	12	10	10,6
Max. Pressure Drop [bar]	cont.	140	175	175	175	175	175	175	135	110
Drop [bar]	int.*	175	200	200	200	200	200	200	175	140
	peak**	225	225	225	225	225	225	225	210	175
Max. Oil Flow [l/min]	cont.	40	60	60	60	60	60	60	60	60
	int.*	50	75	75	75	75	75	75	75	75
Max. Inlet Pressure [bar]	cont.	175	175	175	175	175	175	175	175	175
	int.*	200	200	200	200	200	200	200	200	200
	peak**	225	225	225	225	225	225	225	225	225
Max. Return Pressure with Drain Line [bar]	cont.	175	175	175	175	175	175	175	175	175
	int.*	200	200	200	200	200	200	200	200	200
	peak**	225	225	225	225	225	225	225	225	225
Max. Starting Pressure with Unloaded Shaft, [bar]		10	10	10	9	7	5	4	3	3
Min. Starting Torque [daNm]	at max. press. drop cont.	8	15	20	25	32	41	50	50	50
	at max. press. drop int.*	10	17	23	28	37	46	55	66	61
Min. Speed***, [RPM]		10	10	10	10	10	10	10	10	10
Weight, avg. [kg] For rear ports: +0,650 kg	MR(F)	6,9	7	7,3	7,4	7,6	8,1	8,5	9,2	9,9

* Intermittent operation: the permissible values may occur for max. 10% of every minute.

** Peak load: the permissible values may occur for max. 1% for every minute.

*** For speeds of 10 RPM or lower, consult factory or your regional manager.

1. Intermittent speed and intermittent pressure drop must not occur simultaneously!

2. Recommended filtration is per ISO cleanliness code 20/16. A nominal filtration of 25 micron or better.

3. Recommended using a premium quality, anti-wear type mineral based hydraulic oil HLP(DIN51524) or HM (ISO 6743/4).

If using synthetic fluids consult the factory for alternative seal materials.

4. Recommended minimum oil viscosity 13 mm²/s at operating temperatures.

5. Recommended maximum system operating temperature - 82°C.

6. To assure optimum motor life fill with fluid prior to loading and run at moderate load and speed for 10-15 min.

FUNCTION DIAGRAMS

MR 50

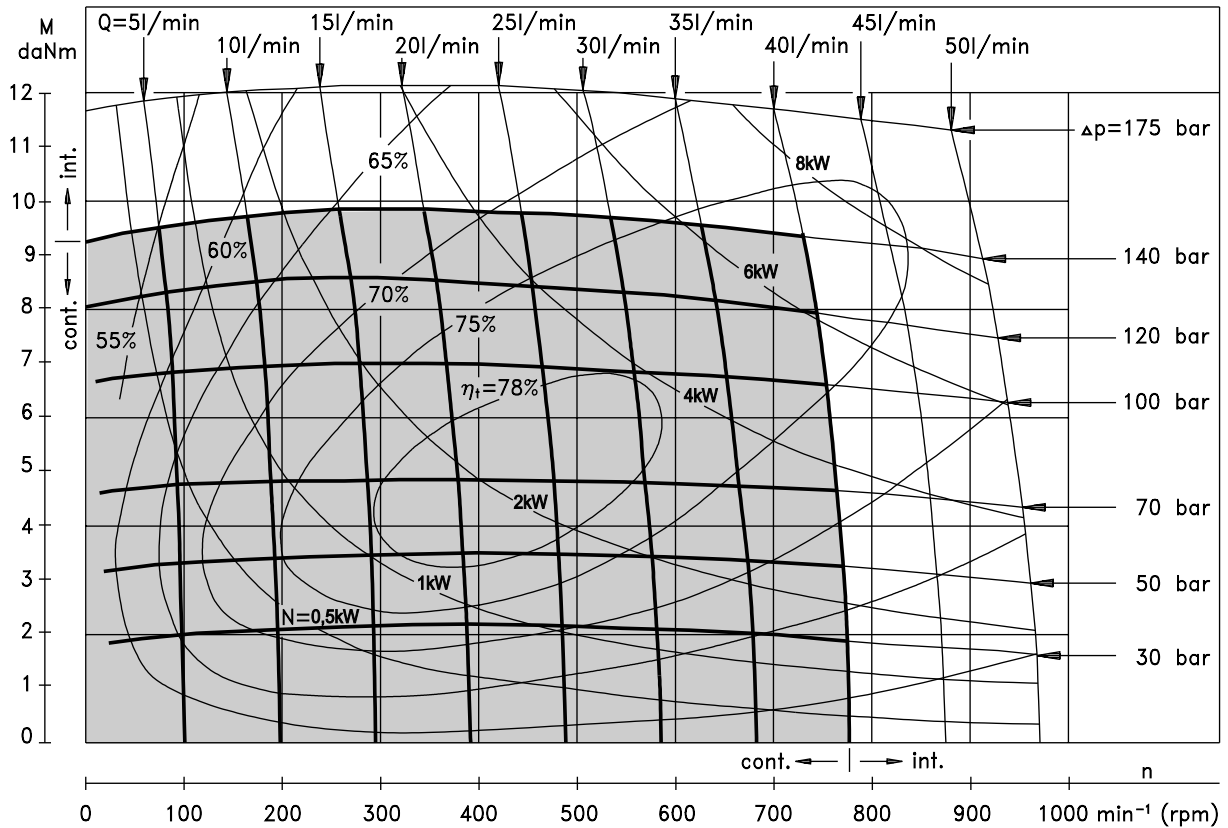

MR 80

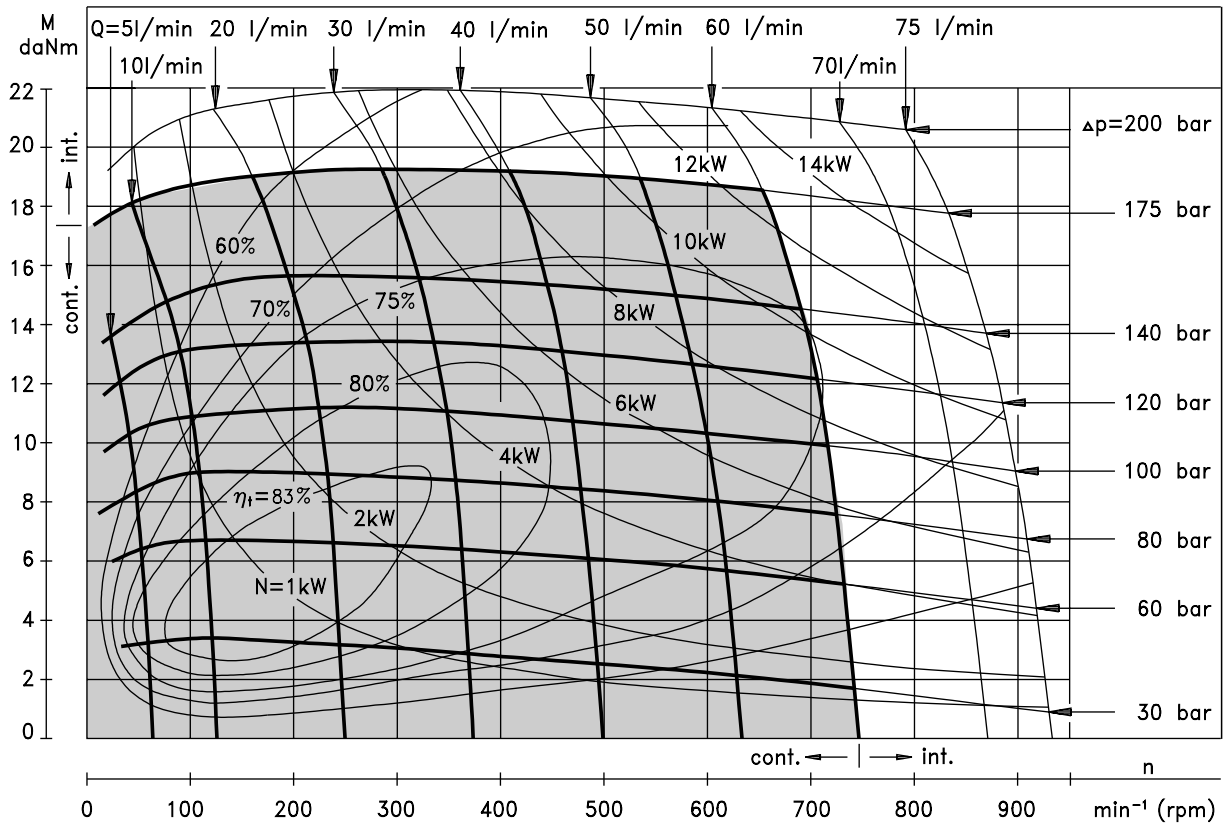

The function diagrams data was collected at back pressure 5 ÷ 10 bar and oil with viscosity of 32 mm²/s at 50° C.

FUNCTION DIAGRAMS

MR 100

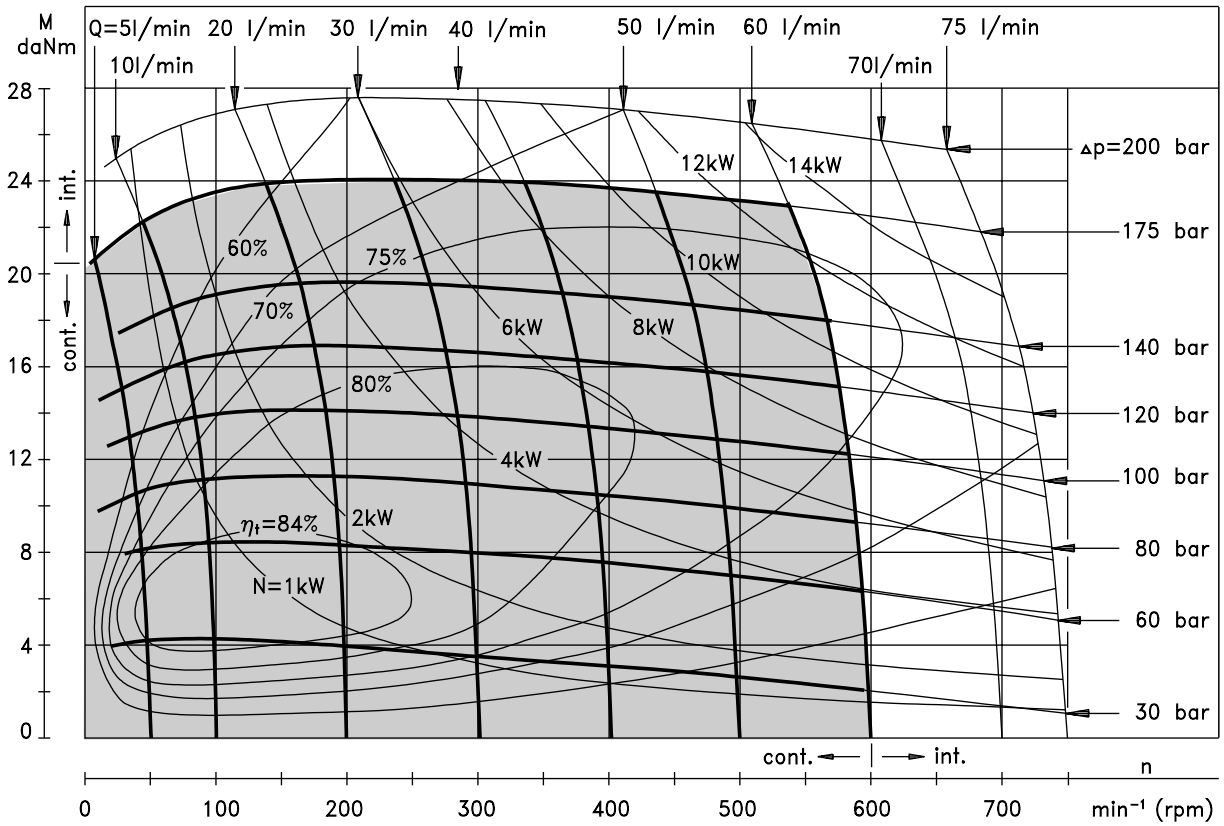

MR 125

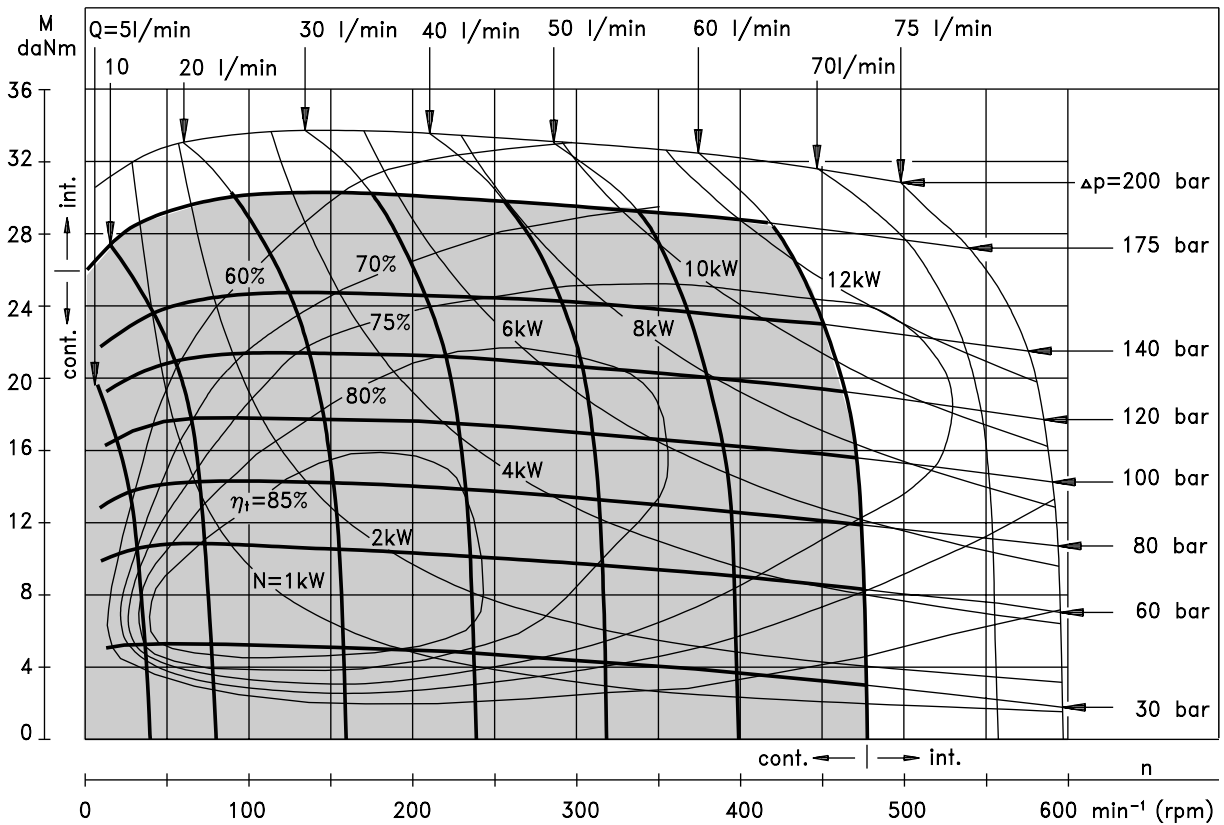

The function diagrams data was collected at back pressure $5 \div 10$ bar and oil with viscosity of $32 \text{ mm}^2/\text{s}$ at 50°C .

FUNCTION DIAGRAMS

MR 160

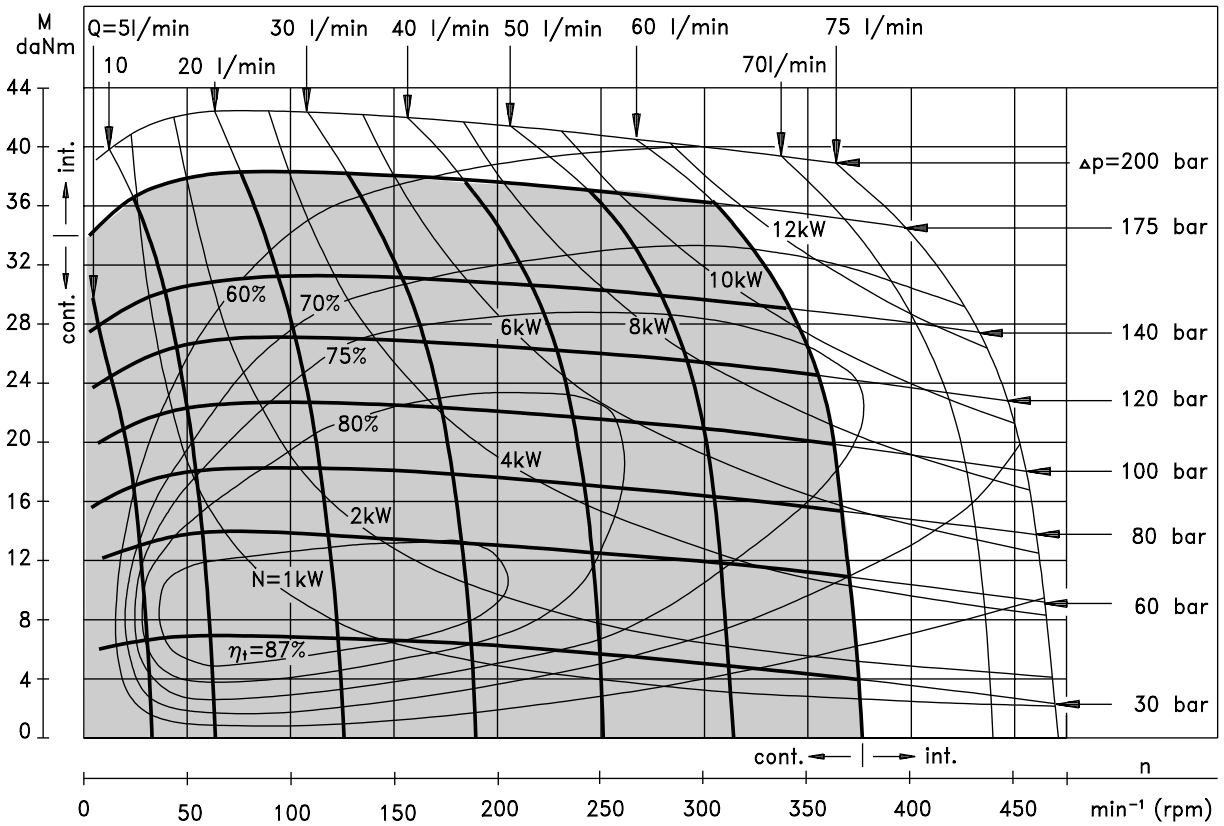

MR 200

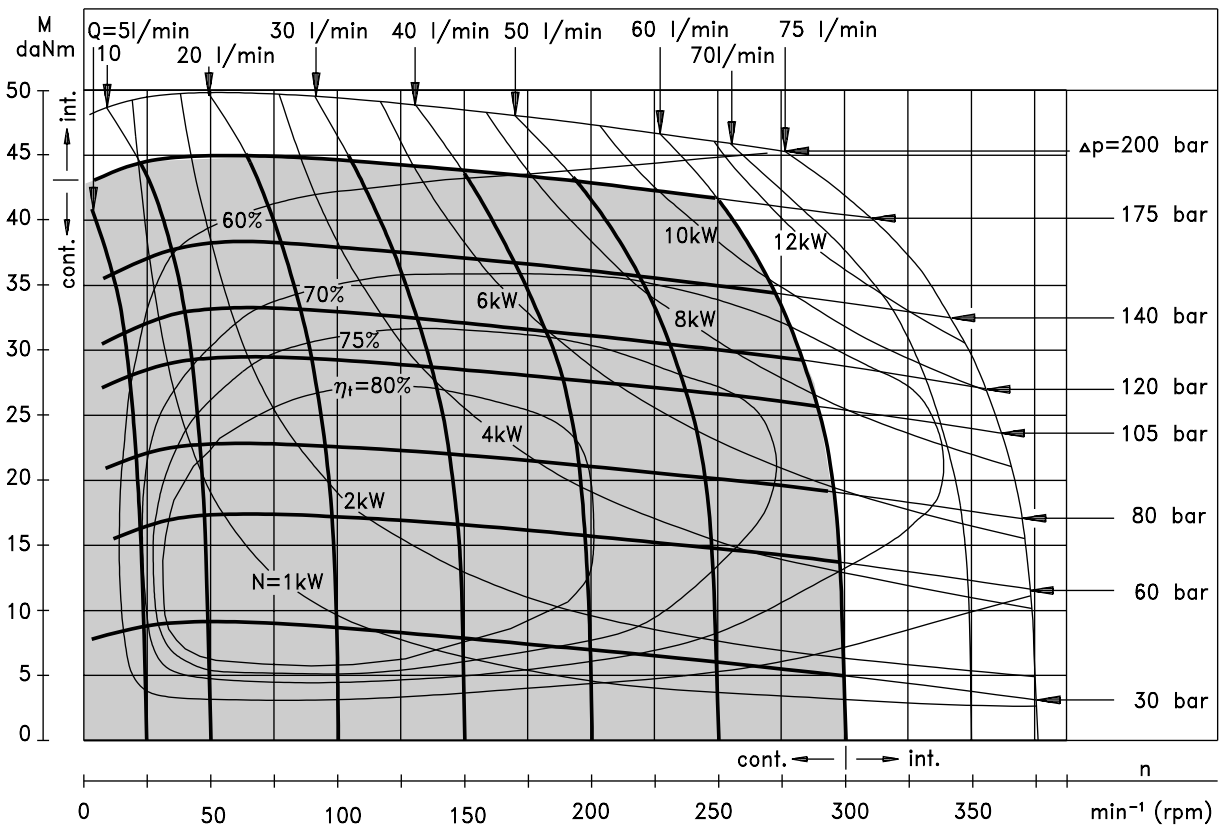

The function diagrams data was collected at back pressure $5 \div 10$ bar and oil with viscosity of $32 \text{ mm}^2/\text{s}$ at 50°C .

FUNCTION DIAGRAMS

MR 250

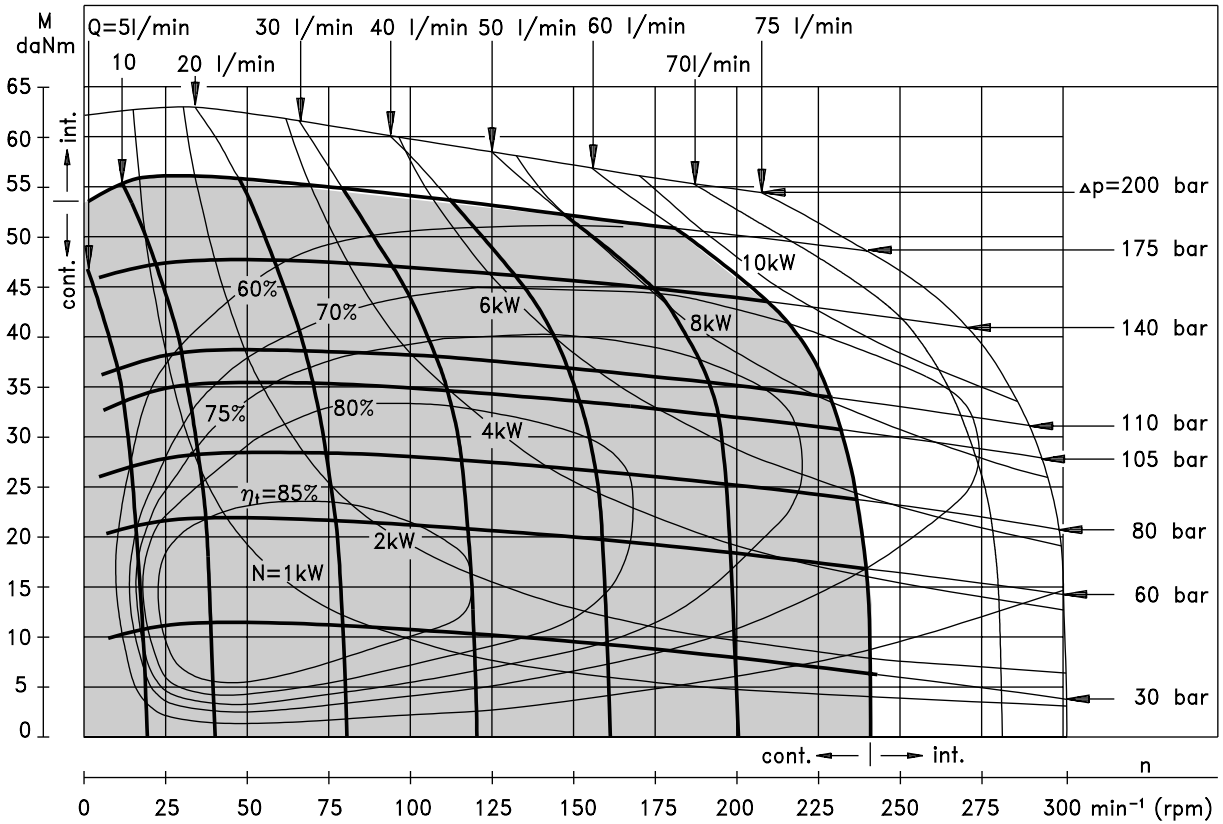

MR 315

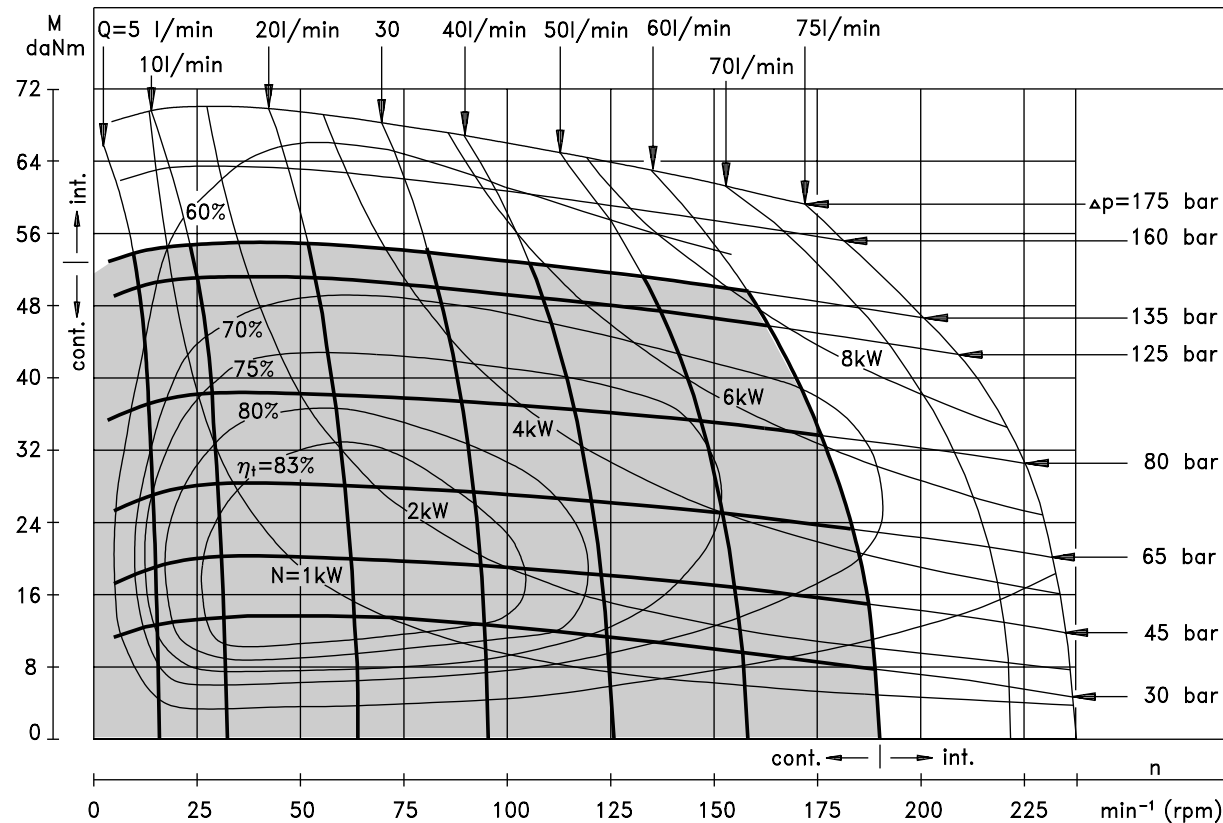

The function diagrams data was collected at back pressure 5 ÷ 10 bar and oil with viscosity of 32 mm²/s at 50° C.

FUNCTION DIAGRAM

MR 400

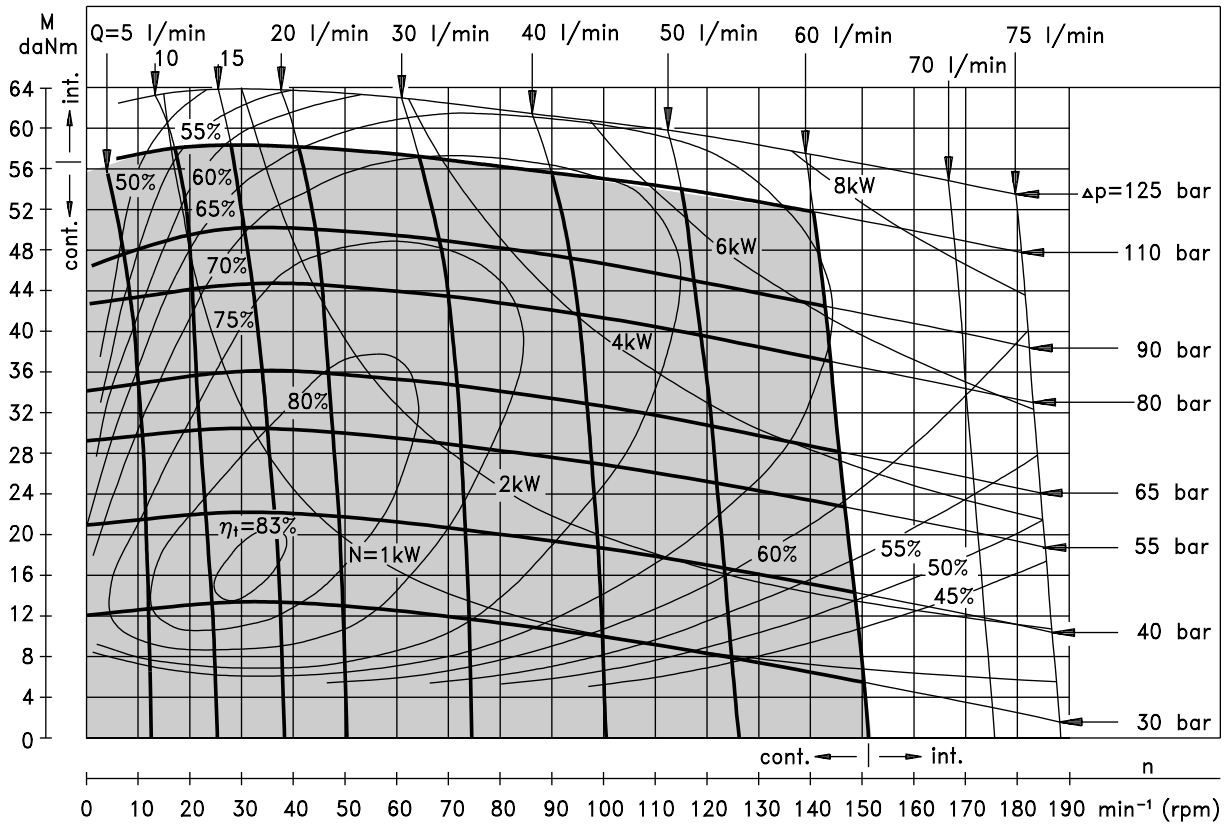

The function diagram data was collected at back pressure 5 ÷ 10 bar and oil with viscosity of 32 mm²/s at 50° C.

DIMENSIONS AND MOUNTING DATA

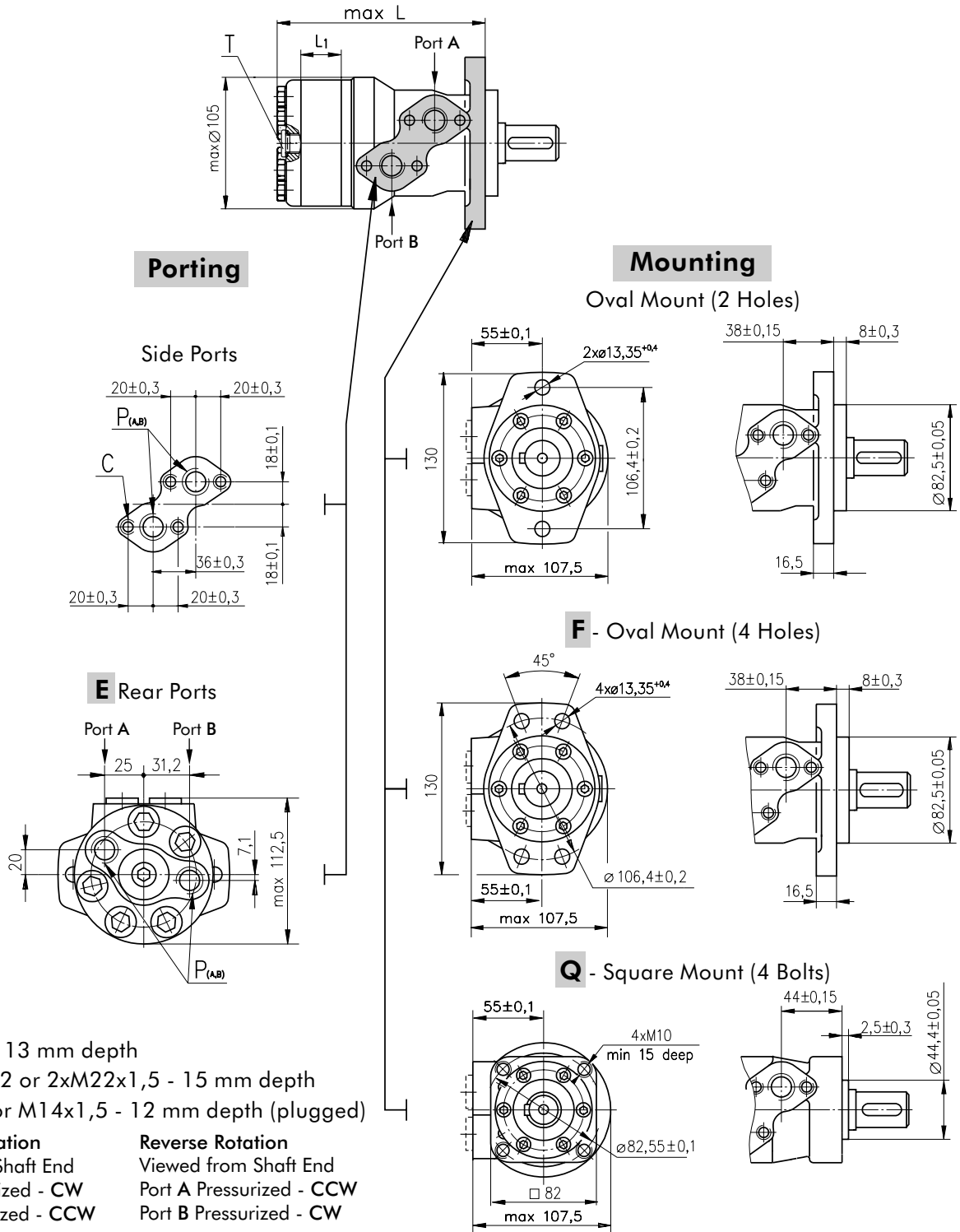

C : 4xM8 - 13 mm depth
P_(A,B): 2xG1/2 or 2xM22x1,5 - 15 mm depth
T : G1/4 or M14x1,5 - 12 mm depth (plugged)

Standard Rotation Viewed from Shaft End
 Port A Pressurized - CW
 Port B Pressurized - CCW

Reverse Rotation Viewed from Shaft End
 Port A Pressurized - CCW
 Port B Pressurized - CW

Type	L, mm	Type	L, mm	Type	L, mm	Type	L, mm	L ₁ , mm
MR(F) 50	138,0	MRQ 50	143,5	MR(F)E 50	157,5	MRQE 50	163,5	9,0
MR(F) 80	143,0	MRQ 80	148,5	MR(F)E 80	162,5	MRQE 80	168,5	14,0
MR(F) 100	146,0	MRQ 100	152,0	MR(F)E 100	165,5	MRQE 100	171,5	17,4
MR(F) 125	150,5	MRQ 125	156,5	MR(F)E 125	170,0	MRQE 125	176,0	21,8
MR(F) 160	156,5	MRQ 160	162,5	MR(F)E 160	176,0	MRQE 160	182,0	27,8
MR(F) 200	163,5	MRQ 200	169,5	MR(F)E 200	183,0	MRQE 200	189,0	34,8
MR(F) 250	172,0	MRQ 250	179,0	MR(F)E 250	192,0	MRQE 250	198,0	43,5
MR(F) 315	183,0	MRQ 315	189,0	MR(F)E 315	204,0	MRQE 315	210,0	54,8
MR(F) 400	198,0	MRQ 400	204,0	MR(F)E 400	218,0	MRQE 400	224,0	69,4

ORDER CODE

	1	2	3	4	5	6	7	8	9	10
M R										

Pos.1 - Mounting Flange

omit - Oval mount, two holes

F - Oval mount, four holes

Q - Square mount, four bolts

Pos.2 - Option (needle bearings)

omit - none

N - with needle bearings

Pos.3 - Port type

omit - Side ports

E - Rear ports

Pos.4 - Displacement code

50 - 51,5 [cm³/rev]

80 - 80,3 [cm³/rev]

100 - 99,8 [cm³/rev]

125 - 125,7 [cm³/rev]

160 - 159,6 [cm³/rev]

200 - 199,8 [cm³/rev]

250 - 250,1 [cm³/rev]

315 - 315,7 [cm³/rev]

400 - 397,0 [cm³/rev]

Pos.5 - Shaft Extensions*(see page 24)

C - ø25 straight, Parallel key A8x7x32 DIN6885

VC - ø25 straight, Parallel key A8x7x32 DIN6885
with corrosion resistant bushing

CO - ø1" straight, Parallel key 1/4"x1/4"x1 1/4" BS46

VCO - ø1" straight, Parallel key 1/4"x1/4"x1 1/4" BS46
with corrosion resistant bushing

SH - ø25,32 splined BS 2059 (SAE 6B)

VSH - ø25,32 splined BS 2059 (SAE 6B)
with corrosion resistant bushing

K - ø28,56 tapered 1:10, Parallel key B5x5x14 DIN6885

SA - ø24,5 splined B 25x22 DIN 5482

VSA - ø24,5 splined B 25x22 DIN 5482
with corrosion resistant bushing

CB - ø32 straight, Parallel key A10x8x45 DIN6885

KB - ø35 tapered 1:10, Parallel key B6x6x20 DIN6885

SB - splined A 25x22 DIN 5482

OB - ø1 1/4" tapered 1:8, Parallel key 5/16"x5/16"x1 1/4" BS46

HB - ø1 1/4" splined 14T ANSI B92.1 - 1976

Pos. 6 - Shaft Seal Version (see page 26)

omit - Low pressure shaft seal or Standard shaft seal
for "...B" shaft

D - Standard shaft seal

U - High pressure shaft seal (without check valves)

Pos. 7 - Drain Port

omit - with drain port

1 - without drain port

Pos. 8 - Ports

omit - BSPP (ISO 228)

M - Metric (ISO 262)

Pos. 9 - Special Features (see page 46)

Pos.10 - Design Series

omit - Factory specified

* The permissible output torque for shafts must not be exceeded!

NOTES: 1. The following combinations are not allowed:- **Q** flange with "...B" shafts;
- **N** option with "...B" shafts, Low Pressure Seal or **U** option;
- "...B" shafts with **D** and **U** shaft seals.

The hydraulic motors are mangano-phosphatized as standard.

HYDRAULIC MOTORS MH



APPLICATION

- » Conveyors
- » Feeding mechanism of robots and manipulators
- » Metal working machines
- » Textile machines
- » Machines for agriculture
- » Food industries
- » Mining machinery etc.

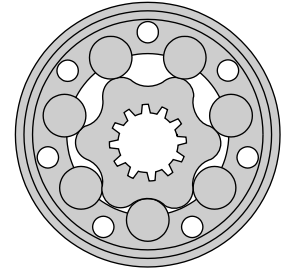

CONTENTS

Specification data 39
 Function diagrams 40÷42
 Permissible shaft loads 43
 Dimensions and mounting ... 44
 Shaft extensions 45
 Order code 45

OPTIONS

- » Model- Spool valve, roll-gerotor
- » Flange mount
- » Shafts- straight, splined and tapered
- » Metric and BSPP ports
- » Other special features

GENERAL

Displacement, [cm ³ /rev.]	201,3÷502,4
Max. Speed, [RPM]	150÷370
Max. Torque, [daNm]	51÷85
Max. Output, [kW]	11÷16
Max. Pressure Drop, [bar]	175÷125
Max. Oil Flow, [l/min]	75
Min. Speed, [RPM]	5÷10
Pressure fluid	Mineral based- HLP(DIN 51524) or HM(ISO 6743/4)
Temperature range, [°C]	-30÷90
Optimal Viscosity range, [mm ² /s]	20÷75
Filtration	ISO code 20/16 (Min. recommended fluid filtration of 25 micron)

Oil flow in drain line

Pressure drop (bar)	Viscosity (mm ² /s)	Oil flow in drain line (l/min)
100	20	2,5
	35	1,8
140	20	3,5
	35	2,8

Pressure Losses

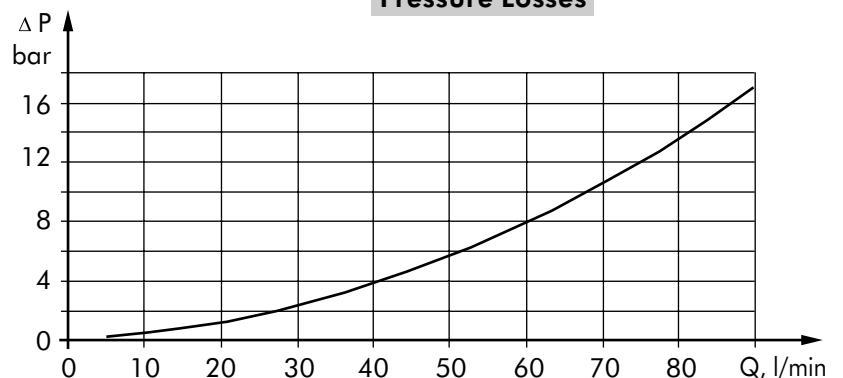

SPECIFICATION DATA

Type	MH					
	200	250	315	400	500	
Displacement, [cm ³ /rev.]	201,3	252	314,9	396,8	502,4	
Max. Speed, [RPM]	cont.	370	295	235	185	150
	int.*	445	350	285	225	180
Max. Torque [daNm]	cont.	51	61	74	84	85
	int.*	58	70	82	98	104
	peak**	64	79	98	109	117
Max. Output, [kW]	cont.	16	16	14	12,5	11
	int.*	18,5	18,5	15,5	15	14
Max. Pressure Drop [bar]	cont.	175	175	175	155	125
	int.*	200	200	200	190	160
	peak**	225	225	225	210	180
Max. Oil Flow [l/min]	cont.	75	75	75	75	75
	int.*	90	90	90	90	90
Max. Inlet Pressure [bar]	cont.	200	200	200	200	200
	int.*	225	225	225	225	225
	peak**	250	250	250	250	250
Max. Starting Pressure with Unloaded Shaft, [bar]	5	5	5	5	5	
Min. Starting Torque [daNm]	at max. press. drop cont.	39	52	66	72	72
	at max. press. drop int.*	45	59	73	88	88
Min. Speed***, [RPM]	10	10	8	5	5	
Weight, avg. [kg]	10,5	11	11,5	12,3	13	

* Intermittent operation: the permissible values may occur for max. 10% of every minute.

** Peak load: the permissible values may occur for max. 1% of every minute.

*** For speeds of 5 RPM lower than given, consult factory or your regional manager.

- 1) Intermittent speed and intermittent pressure must not occur simultaneously.
- 2) Recommended filtration is per ISO cleanliness code 20/16. A nominal filtration of 25 micron or better.
- 3) Recommend using a premium quality, anti-wear type mineral based hydraulic oil, HLP(DIN51524) or HM(ISO6743/4).
If using synthetic fluids consult the factory for alternative seal materials.
- 4) Recommended minimum oil viscosity 13 mm²/s at 50°C.
- 5) Recommended maximum system operating temperature is 82°C.
- 6) To assure optimum motor life fill with fluid prior to loading and run at moderate load and speed for 10-15 minutes.

FUNCTION DIAGRAMS

MH 200

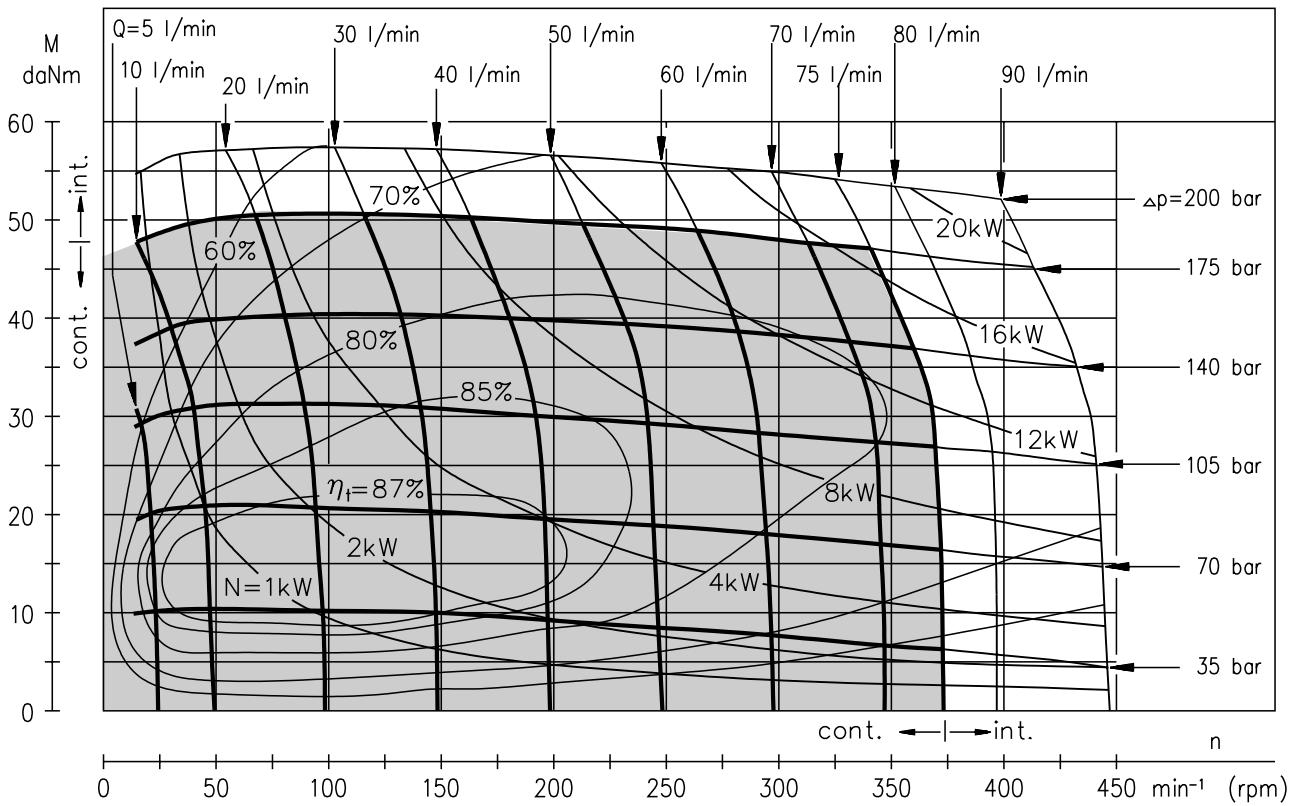

MH 250

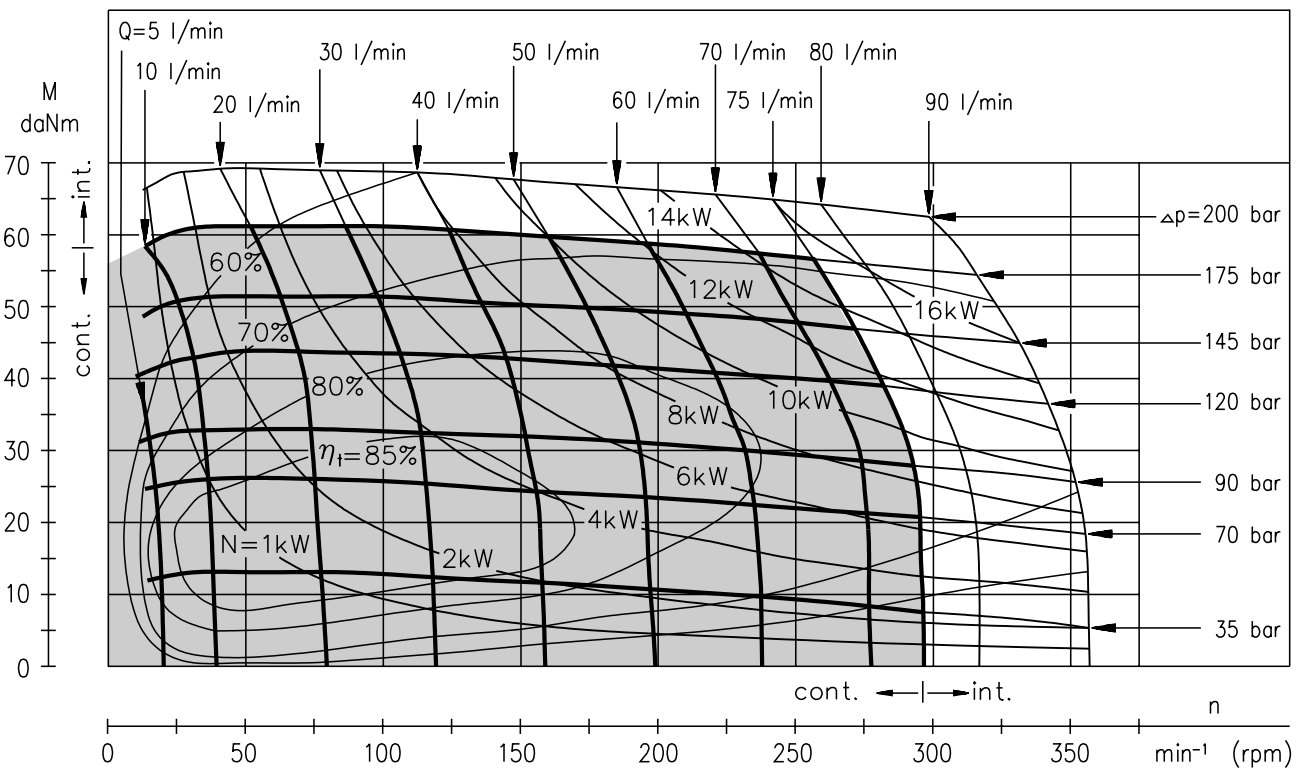

The function diagrams data was collected at back pressure 5 ÷ 10 bar and oil with viscosity of 32 mm²/s at 50° C.

FUNCTION DIAGRAMS

MH 315

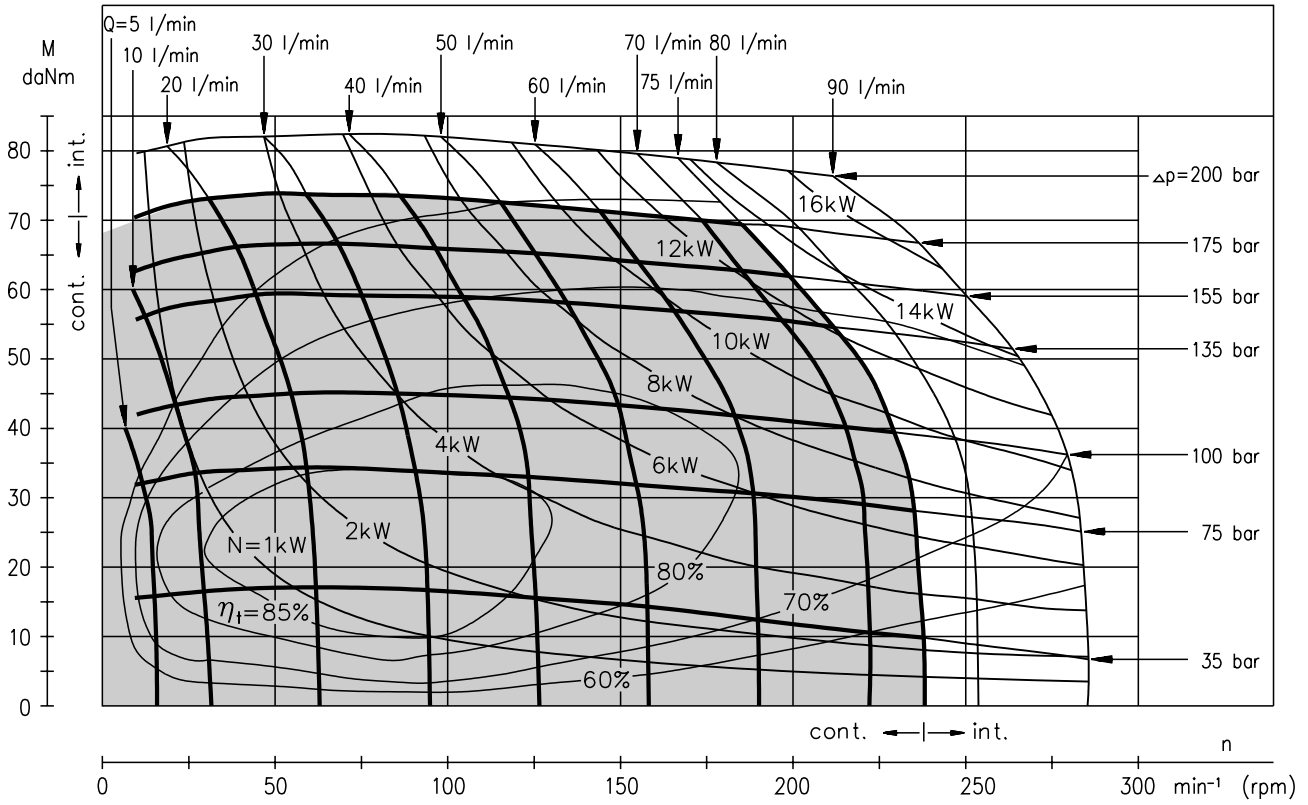

MH 400

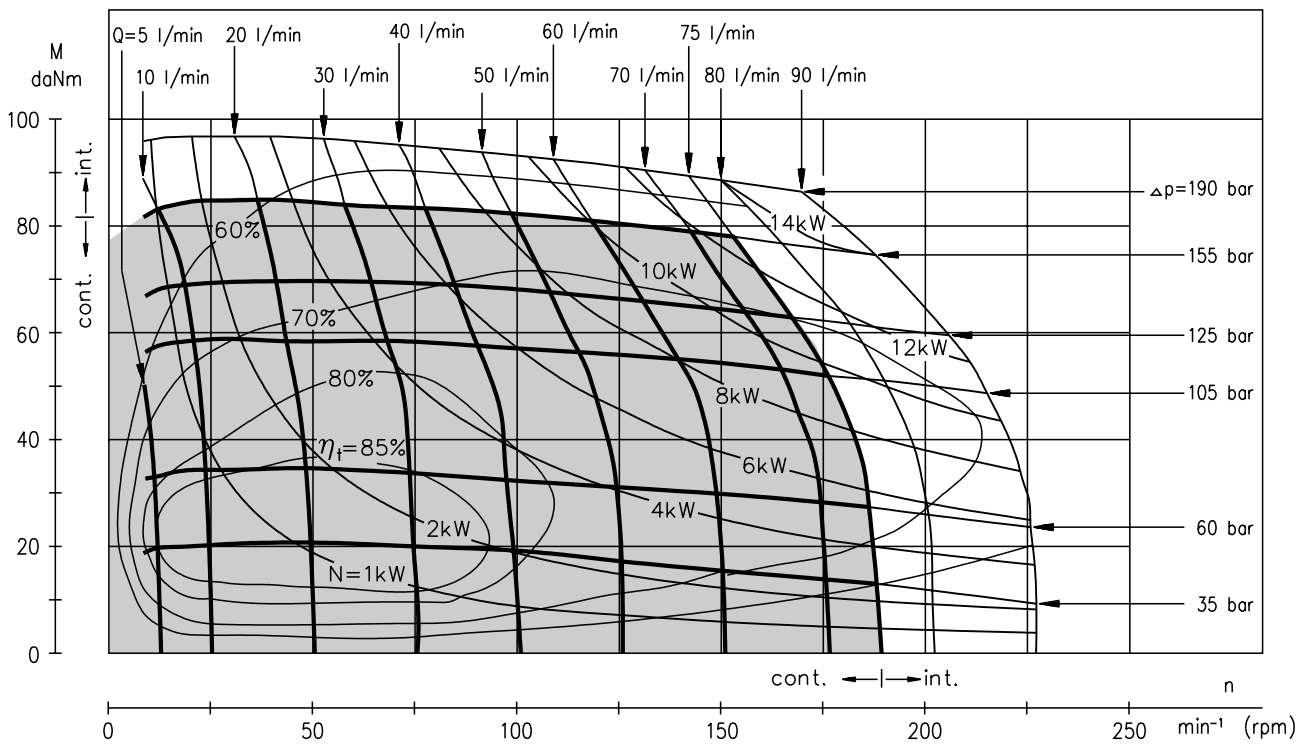

The function diagrams data was collected at back pressure 5 ÷ 10 bar and oil with viscosity of 32 mm²/s at 50° C.

FUNCTION DIAGRAMS

MH 500

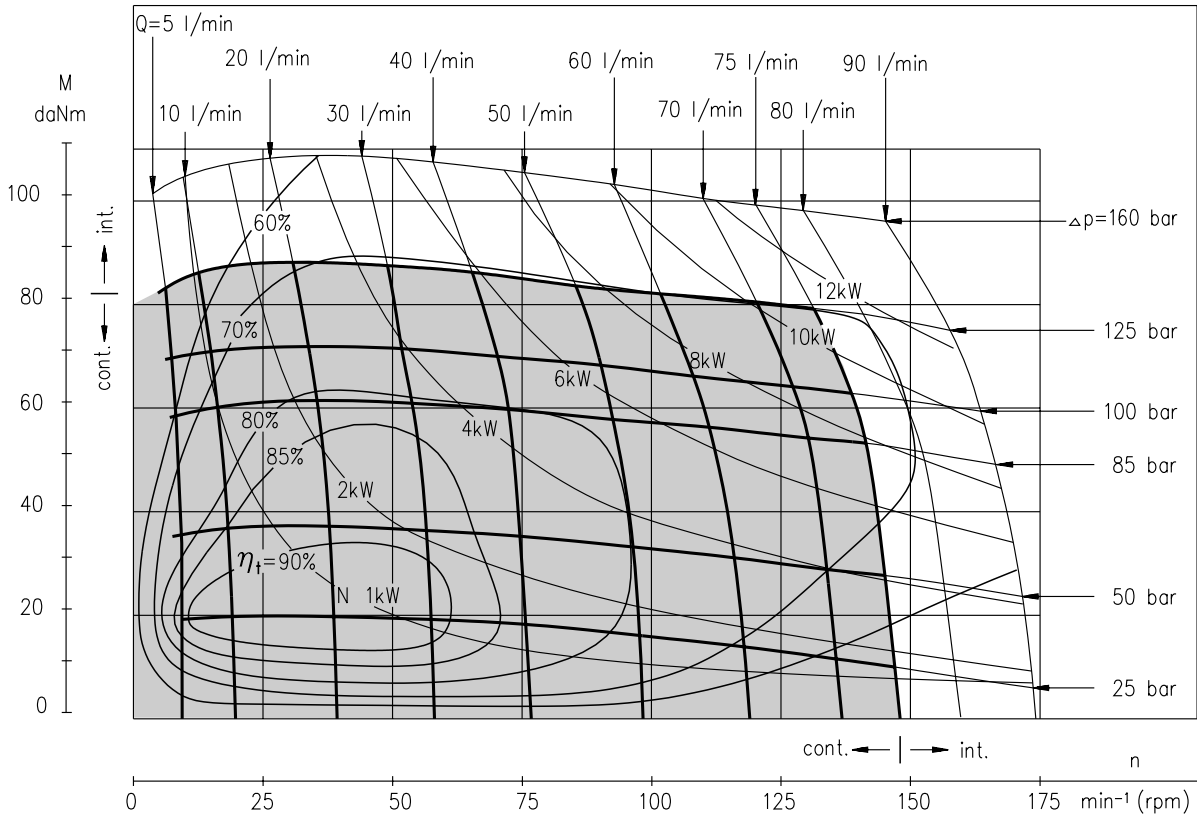

The function diagrams data was collected at back pressure 5 ÷ 10 bar and oil with viscosity of 32 mm²/s at 50° C.

PERMISSIBLE SHAFT LOADS FOR MH MOTORS

The permissible radial shaft load P_{rad} depends on the speed (RPM) and distance (L) from the point of load to the mounting flange.

$$\text{Radial Shaft Load } P_{rad} = \frac{1100}{n} \times \frac{25000}{103,5+L}, \text{ daN}^*$$

*L < 60 mm; n ≥ 200 min⁻¹

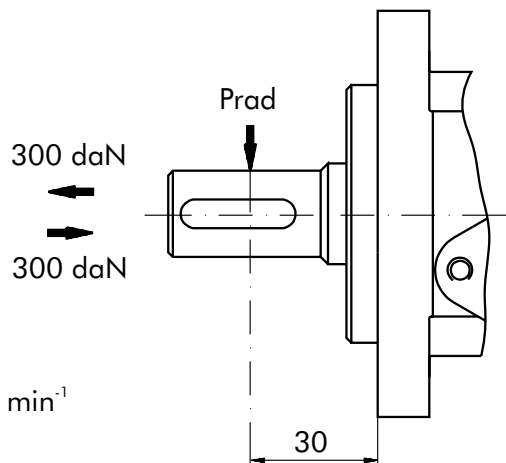
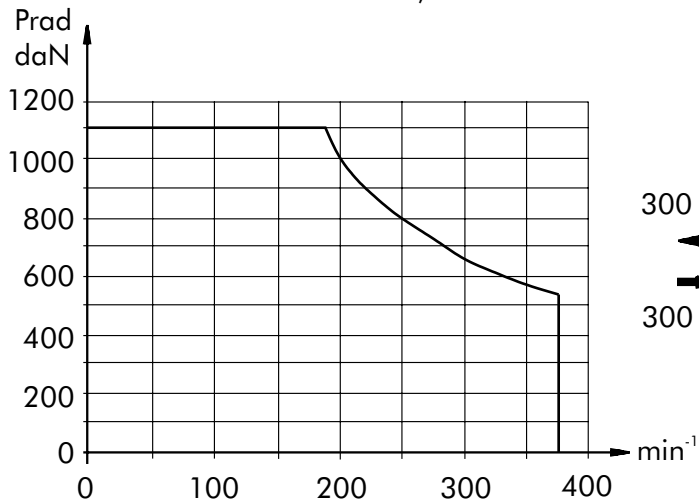

DIMENSIONS AND MOUNTING DATA

Magneto Maunt (4 holes)

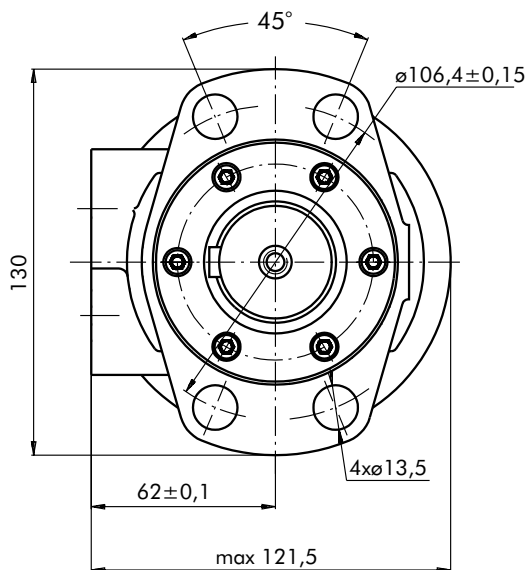
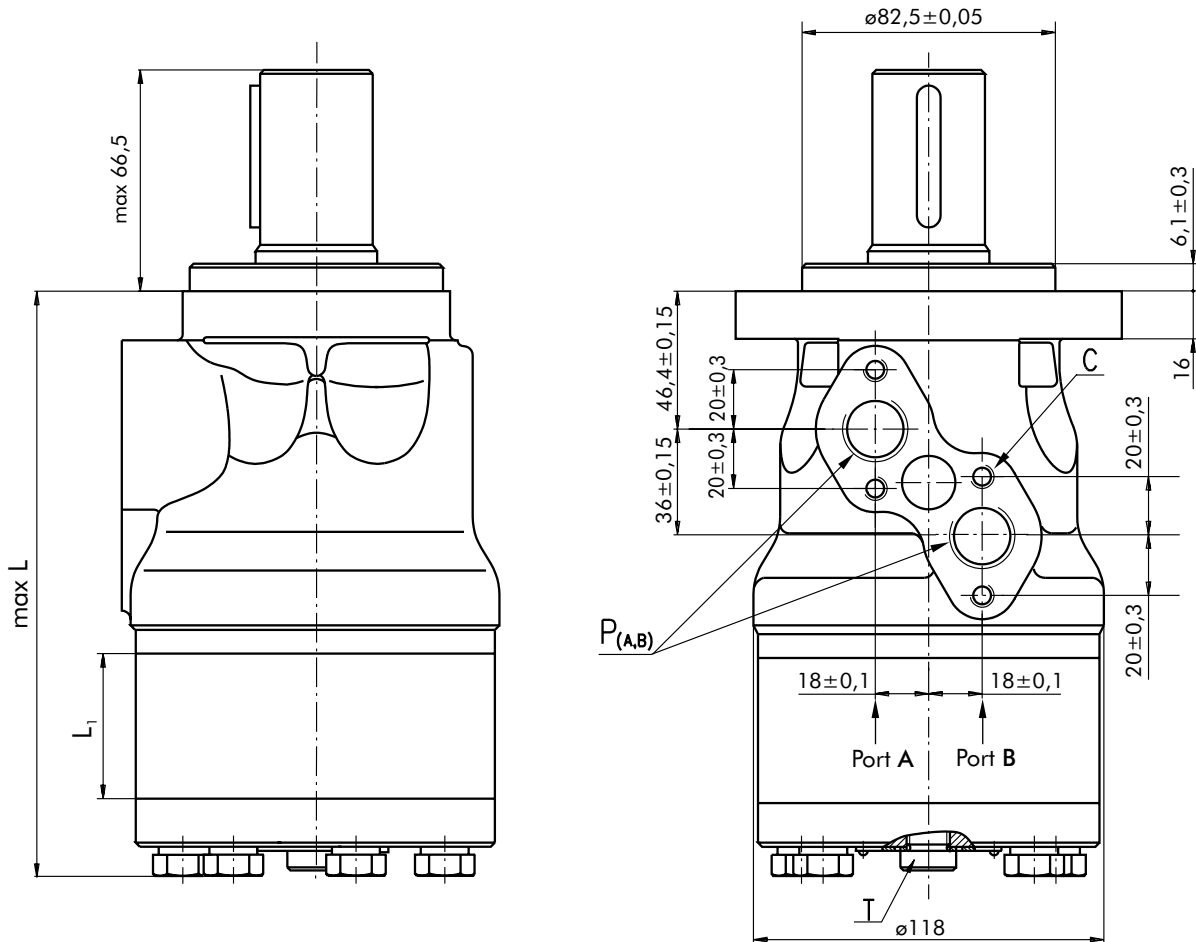

Type	L, mm	L ₁ , mm
MH 200	169	27,8
MH 250	176	34,8
MH 315	184	43,5
MH 400	196	54,8
MH 500	211	69,4

- C** : 4xM8-13 mm depth
- P_(A,B)**: 2xG1/2 or 2xM22x1,5-15 mm depth
- T** : G1/4 or M14x1,5-12 mm depth (plugged)

Standard Rotation
Viewed from Shaft End
Port A Pressurized - CW
Port B Pressurized - CCW

Reverse Rotation
Viewed from Shaft End
Port A Pressurized - CCW
Port B Pressurized - CW

MAX. PERMISSIBLE SHAFT SEAL PRESSURE FOR MH MOTORS

MH...U1 motors with high pressure seal and without drain connection:

The shaft seal pressure equals the average of input pressure and return pressure.

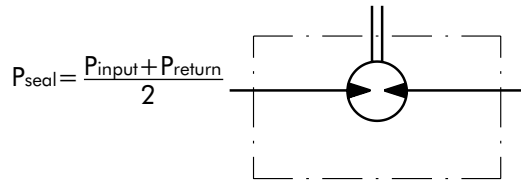

MH...U motors with high pressure seal and drain connection:

The shaft seal pressure equals the pressure in the drain line.

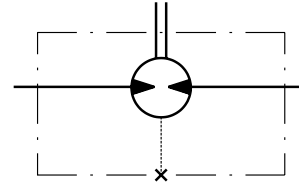

MH...1 motors with standard shaft seal and without drain connection:

The shaft seal pressure never exceeds the pressure in the return line.

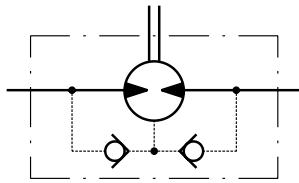

MH... motors with standard shaft seal and with drain connection:

The shaft seal pressure equals the pressure in the drain line.

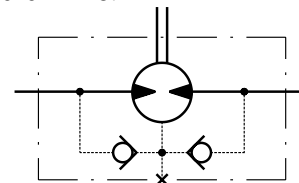

Max. return pressure without drain line or max. pressure in the drain line

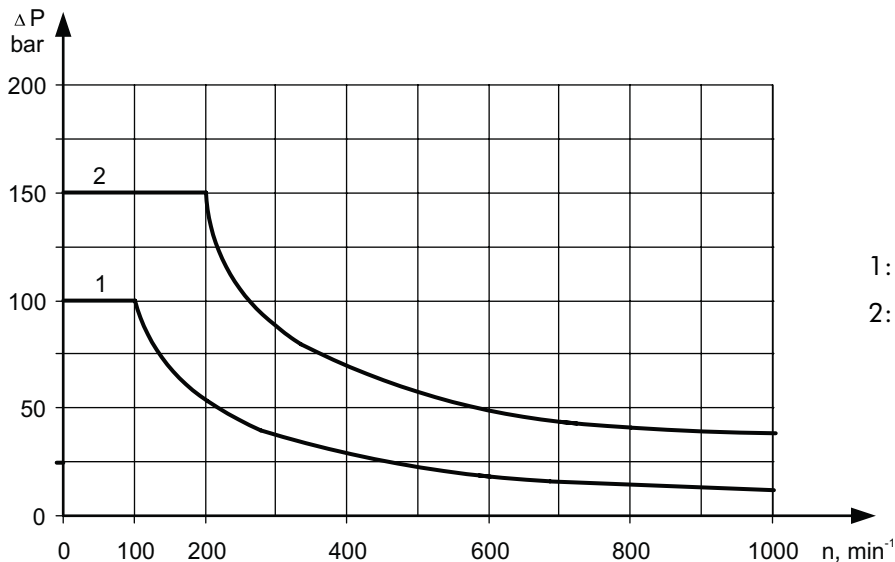

1: Drawing for Standard Shaft Seal
2: Drawing for High Pressure Seal ("U" Seal)

SHAFT EXTENSIONS

C - $\varnothing 32$ straight, Parallel key A10x8x45 DIN 6885
Max. Torque 77 daNm

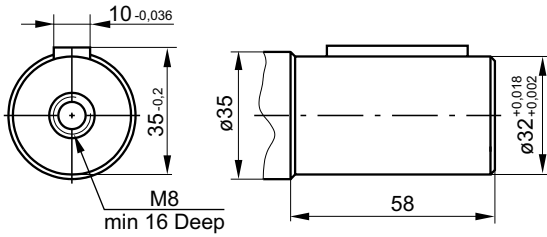

SH - $\varnothing 1\frac{1}{4}$ " splined 14T, DP 12/24 ANSI B92.1-1976
Max. Torque 95 daNm

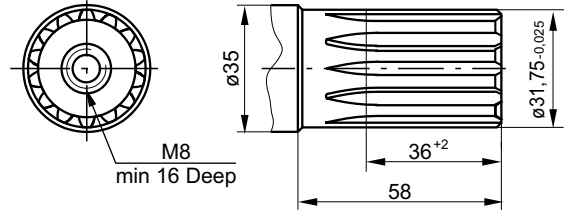

CB - $\varnothing 35$ straight, Parallel key A10x8x45 DIN 6885
Max. Torque 95 daNm

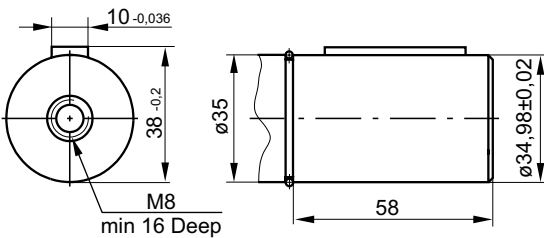

K - tapered 1:10, Parallel key B6x6x20 DIN 6885
Max. Torque 95 daNm

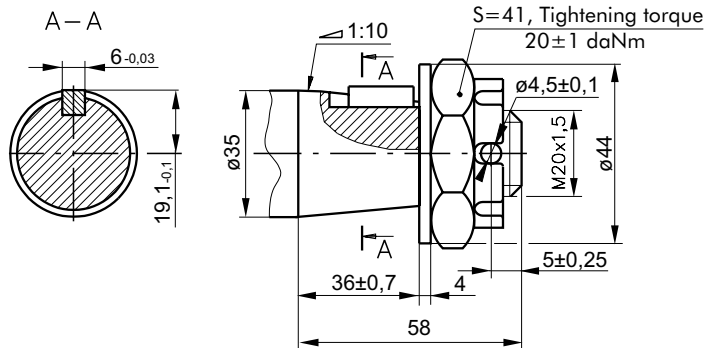

ORDER CODE

	1	2	3	4	5	6	7
MH							

Pos. 1 - Displacement code

200	- 201,3 [cm ³ /rev]
250	- 252,0 [cm ³ /rev]
315	- 314,9 [cm ³ /rev]
400	- 396,8 [cm ³ /rev]
500	- 502,4 [cm ³ /rev]

Pos. 2 - Shaft Extensions *

C	- $\varnothing 32$ straight, Parallel key A10x8x45 DIN 6885
SH	- $\varnothing 1\frac{1}{4}$ " splined 14T ANSI B92.1-1976
CB	- $\varnothing 35$ straight, Parallel key A10x8x45 DIN 6885
K	- $\varnothing 35$ tapered 1:10, Parallel key B6x6x20 DIN 6885

Pos. 3 - Shaft Seal Version (see page 44)

omit	- Standard shaft seal
U	- High pressure shaft seal (without check valves)

Pos. 4 - Drain Port

omit	- with drain port
1	- without drain port

Pos. 5 - Ports

omit	- BSPP (ISO 228)
M	- Metric (ISO 262)

Pos. 6 - Special Features (see page 46)

Pos. 7 - Design Series

omit	- Factory specified
------	---------------------

NOTES:

- * The permissible output torque for shafts must be not exceeded!
- The hydraulic motors are mangano-phosphatized as standard.

MOTOR SPECIAL FEATURES

Special Feature Description	Order Code	Motor type						
		MM	MP	MPN	MPW	MR	MRN	MH
Motor for Speed Sensor*	RS	○	○	-	-	○	-	○
Low Leakage	LL	○	○	-	○	○	-	○
Low Speed Valving	LSV	○	○	-	○	○	-	○
Free Running	FR	○	○	-	○	○	-	○
Reverse Rotation	R	○	○	○	○	○	○	○
Paint**	P	○	○	○	○	○	○	○
Corrosion Protected Paint**	PC	○	○	○	○	○	○	○
Check Valves		S	S***	S	S	S***	S	S

- Optional
- Not applicable
- S Standard

* for sensor ordering see pages 47-48

** color at customer's request.

*** without check valves for "U" shaft seal versions (see page 26)

MOTORS WITH SPEED SENSOR

MM...RS

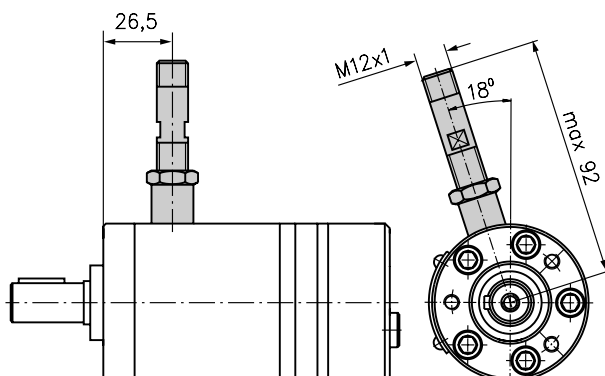

MP...RS and MR...RS

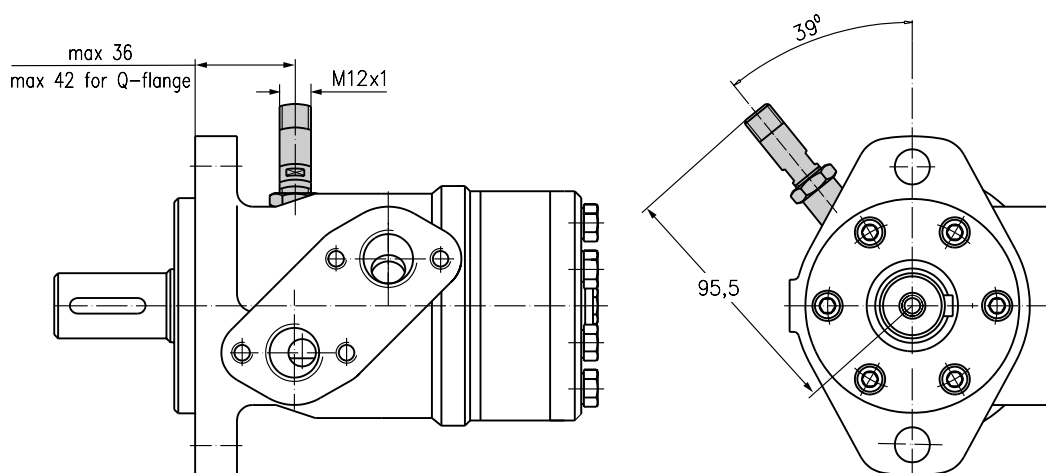

MH...RS

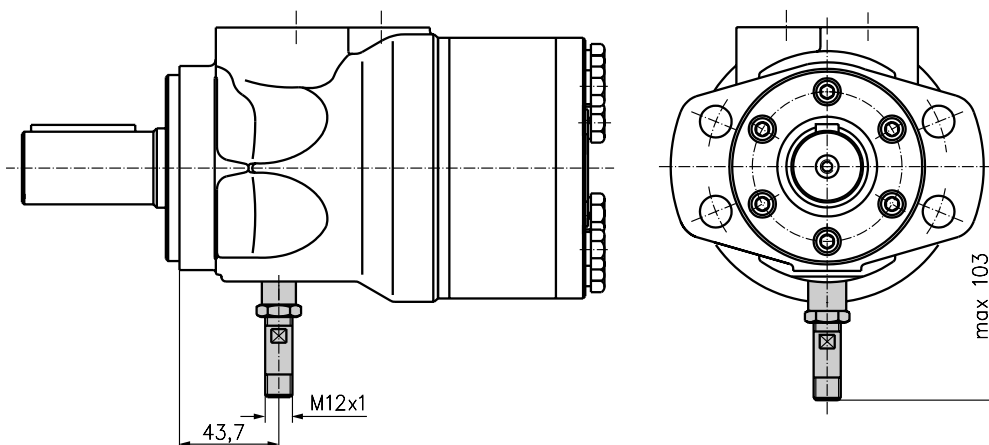

TECHNICAL DATA OF THE SPEED SENSOR

Technical data

Frequency range	3...20 000 Hz
Output	PNP, NPN
Power supply	10...36 VDC
Current input	20 mA (@24 VDC)
Current load	500 mA (@24 VDC; 24°C)
Ambient Temperature	minus 40... plus 125°C
Protection	IP 67
Plug connector	M12-Series
Mounting principle	ISO 6149

Output signal

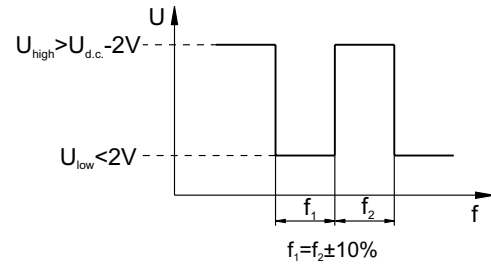

Load max.: $I_{high} = I_{low} < 50\text{mA}$
 No load current, max: 20 mA

Motor type	MM	MP	MR	MH
Pulses per revolution	30	36	36	42

Wiring diagrams

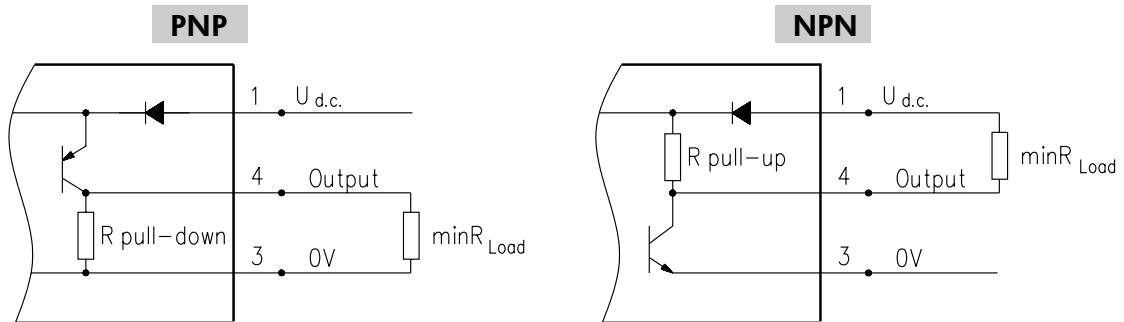

$$R_{Load} = U_{d.c.} / I_{max} (=50\text{mA})$$

Stick type

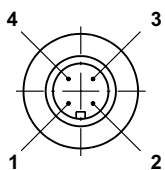

Terminal No.	Connection	Cable Output
1	$U_{d.c.}$	Brown
2	No connection	White
3	0V	Blue
4	Output signal	Black

Order Code for Speed Sensor

Sensor Code	Output type	Electric connection
RSN	NPN	Connector BINDER 713 series
RSP	PNP	Connector BINDER 713 series
RSNL5	NPN	Cable output 3x0,25; 5m long
RSPL5	PNP	Cable output 3x0,25; 5m long

NOTE: * - The speed sensor is not fitted at the factory, but is supplied in a plastic bag with the motor. For installation see enclosed instructions.

MOTOR APPLICATION

VEHICLE DRIVE CALCULATIONS

1. Motor speed: n , [min^{-1}]

$$n = \frac{2,65 \times v \times i}{R}$$

v - vehicle speed, [km/h];

R - wheel rolling radius, [m];

i - gear ratio between motor and wheels.

If no gearbox, use $i = 1$.

2. Rolling resistance: RR , [daN]

The resistance force resulted in wheels contact with different surfaces:

$$RR = G \times \rho$$

G - total weight loaded on vehicle, [daN];

ρ - rolling resistance coefficient (Table 1).

Table 1

Rolling resistance coefficient In case of rubber tire rolling on different surfaces	
Surface	ρ
Concrete- faultless	0,010
Concrete- good	0,015
Concrete- bad	0,020
Asphalt- faultless	0,012
Asphalt- good	0,017
Asphalt- bad	0,022
Macadam- faultless	0,015
Macadam- good	0,022
Macadam- bad	0,037
Snow- 5 cm	0,025
Snow- 10 cm	0,037
Polluted covering- smooth	0,025
Polluted covering- sandy	0,040
Mud	$0,037 \div 0,150$
Sand- Gravel	$0,060 \div 0,150$
Sand- loose	$0,160 \div 0,300$

3. Grade resistance: GR , [daN]

$$GR = G \times (\sin \alpha + \rho \times \cos \alpha)$$

α - gradient negotiation angle (Table 2)

Table 2

Grade %	α Degrees	Grade %	α Degrees
1%	$0^\circ 35'$	12%	$6^\circ 5'$
2%	$1^\circ 9'$	15%	$8^\circ 31'$
5%	$2^\circ 51'$	20%	$11^\circ 19'$
6%	$3^\circ 26'$	25%	$14^\circ 3'$
8%	$4^\circ 35'$	32%	18°
10%	$5^\circ 43'$	60%	31°

4. Accelerate force: FA , [daN]

Force FA necessary for acceleration from 0 to maximum speed v and time t can be calculated with a formula:

$$FA = \frac{v \times G}{3,6 \times t}, [\text{daN}]$$

FA - accelerate force, [daN];

t - time, [s].

5. Tractive effort: DP , [daN]

Tractive effort DP is the additional force of trailer. This value will be established as follows:

-acc.to constructor's assessment;

-as calculating forces in items 2, 3 and 4 of trailer; the calculated sum corresponds to the tractive effort requested.

6. Total tractive effort: TE , [daN]

Total tractive effort TE is total effort necessary for vehicle motion; that the sum of forces calculated in items from 2 to 5 and increased with 10 % because of air resistance.

$$TE = 1,1 \times (RR + GR + FA + DP)$$

RR - force acquired to overcome the rolling resistance;

GR - force acquired to slope upwards;

FA - force acquired to accelerate (acceleration force);

DP - additional tractive effort (trailer).

7. Motor Torque: M , [daNm]

Necessary torque moment for every hydraulic motor:

$$M = \frac{TE \times R}{N \times i \times \eta_M}$$

N - motor numbers;

η_M - mechanical gear efficiency (if it is available).

8. Cohesion between tire and road covering: M_w , [daNm]

$$M_w = \frac{G_w \times f \times R}{i \times \eta_M}$$

To avoid wheel slipping, it should be observed the following condition $M_w > M$

f - frictional factor;

G_w - total weight over the wheels, [daN].

Table 3

Surface	Frictional factor f
Steel on steel	$0,15 \div 0,20$
Rubber tire on polluted surface	$0,5 \div 0,7$
Rubber tire on asphalt	$0,8 \div 1,0$
Rubber tire on concrete	$0,8 \div 1,0$
Rubber tire on grass	0,4

9.Radial motor loading: P_{rad} , [daN]

When motor is used for vehicle motion with wheels mounted directly on motor shaft, the total radial loading of motor shaft P_{rad} is a sum of motion force and weight force acting on one wheel.

G_w - Weight held by wheel;

P_{rad} - Total radial loading of motor shaft;

M/R - Motion force.

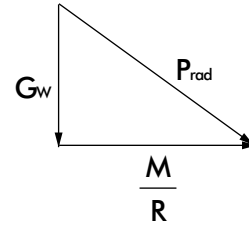

$$P_{rad} = \sqrt{G_w^2 + \left(\frac{M}{R}\right)^2}$$

In accordance with calculated loadings the suitable motor from the catalogue is selected.

DRAINAGE SPACE AND DRAINAGE PRESSURE

Advantages in oil drainage from drain space: Cleaning; Cooling and Seal lifetime prolonging.

