

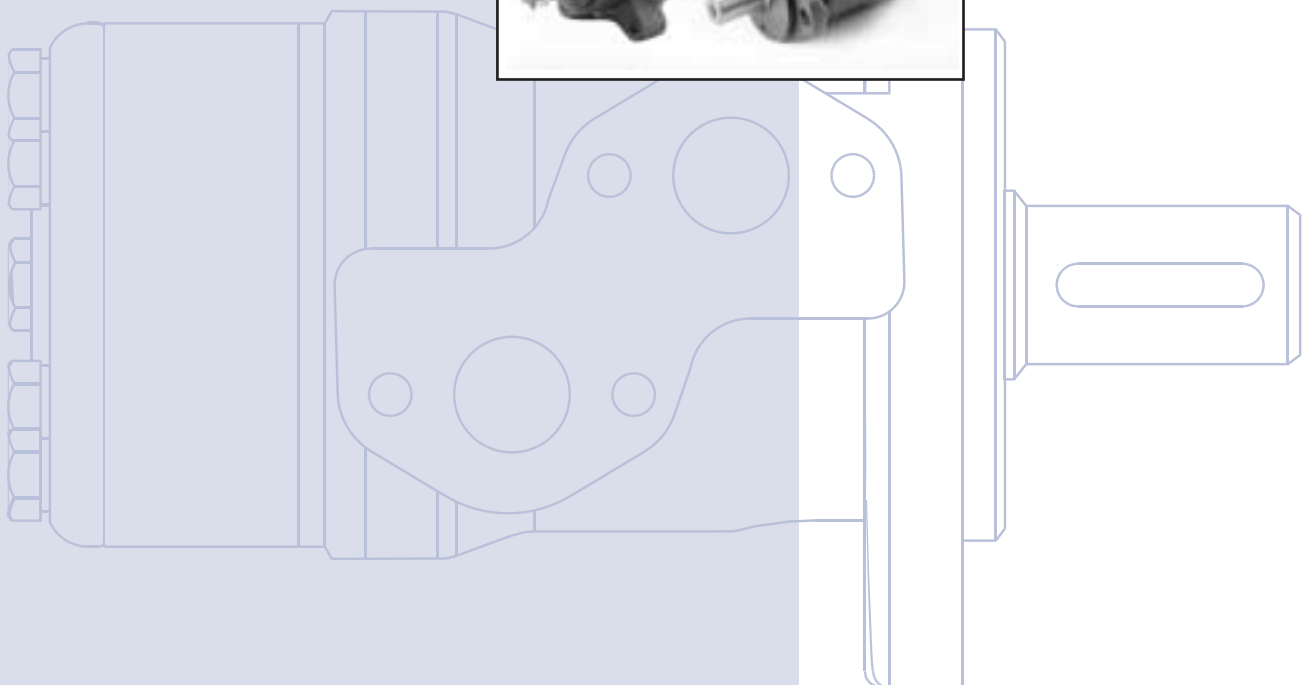

OMP, OMR, OMH
and OMEW

Technical
Information

Hydraulic Motors





Motorer.TIF

**A WIDE RANGE OF
HYDRAULIC MOTORS**

Sauer-Danfoss is a world leader within production of low speed hydraulic motors with high torque. We can offer more than 1600 different hydraulic motors, categorised in types, variants and sizes (incl. different shaft versions).

The motors vary in size (rated displacement) from 8 cm³ (0.50 in³) to 800 cm³ (48.9 in³) per revolution.

Speeds range up to approx. 2500 min⁻¹ (rpm) for the smallest type and up to approx 600 min⁻¹ (rpm) for the largest type.

Maximum operating torques vary from 13 Nm (115 lbf·in) to 2700 Nm (24.000 lbf·in) (peak) and maximum outputs are from 2,0 kW (2,7 hp) to 70 kW (95 hp).

Characteristic features:

- Smooth running over the entire speed range
- Constant operating torque over a wide speed range
- High starting torque
- High return pressure without the use of drain line (High pressure shaft seal)
- High efficiency
- Long life under extreme operating conditions
- Robust and compact design
- High radial and axial bearing capacity
- For applications in both open and closed loop hydraulic systems
- Suitable for a wide variety of hydraulics fluids

© 2001 Sauer-Danfoss

Sauer-Danfoss can accept no responsibility for possible errors in catalogues, brochures and other printed material. Sauer-Danfoss reserves the right to alter its products without prior notice. This also applies to products already ordered provided that such alterations can be made without subsequent changes being necessary in specifications already agreed. All trademarks in this material are properties of the respective companies. Sauer-Danfoss and the Sauer-Danfoss logotype are trademarks of the Sauer-Danfoss Group. All rights reserved.

Frontpage: Drawing 151-1837, F73375.TIF, F73337.TIF, F73338.TIF, F66104.TIF, F71934.eps

OMP, OMR, OMH and OMEW Hydraulic Motor A wide range of hydraulic motors

The programme is characterised by technical features appealing to a large number of applications and a part of the programme is characterised by motors that can be adapted to a given application. Adaptions comprise the following variants among others:

- Motors with corrosion resistant parts
- Wheel motors with recessed mounting flange
- OMP, OMR- motors with needle bearing
- OMR motor in low leakage version
- OMR motors in a super low leakage version
- Short motors without bearings
- Ultra short motors
- Motors with integrated positive holding brake
- Motors with integrated negative holding brake
- Motors with integrated flushing valve
- Motors with speed sensor
- Motors with tacho connection
- All motors are available with black finish paint

Planetary gears

Sauer - Danfoss complements the motor range with a complete programme of planetary gears adapted to suit. The combination of motors and gears makes it possible to obtain smooth running at fractional speeds and with torques up to 650.000 Nm (5.800.000 lbf-in).

The Sauer–Danfoss LSHT motors are used in the following application areas:

- Construction equipment
- Agricultural equipment
- Material handling & Lifting equipment
- Forestry equipment
- Lawn and turf equipment
- Special purpose
- Machine tools and stationary equipment
- Marine equipment

SURVEY OF LITERATURE WITH TECHNICAL DATA ON DANFOSS HYDRAULIC MOTORS

Detailed data on all Sauer-Danfoss motors can be found in our motor catalogue, which is divided into 5 individual subcatalogues:

- General information on Sauer-Danfoss hydraulic motors: function, use, selection of hydraulic motor, hydraulic systems, etc.
- Technical data on small motors: OML and OMM
- Technical data on medium sized motors: OMP, OMR, OMH and OMEW
- Technical data on medium sized motors: DH and DS
- Technical data on large motors: OMS, OMT and OMV
- Technical data on large motors: TMT

A general survey brochure on Sauer-Danfoss hydraulic motors gives a quick motor reference based on power, torque, speed and capabilities.

CONTENTS

	Page
OMP, OMR, OMH and OMEW	6
Speed, torque and output	6
OMP	8
Version.....	8
Code number	9
Technical data	10-26
Technical data (e.g. speed, torque, pressure etc.)	10-12
Max. permissible shaft seal pressure.....	13
Pressure drop in motor, oil flow in drain line, direction of shaft rotation	14
Permissible shaft loads	15-17
Function diagrams	18-23
Shaft version	24-25
Port thread versions.....	26
Dimensions.....	27-35
OMR	36
Version.....	36
Code number	37
Technical data	38-54
Technical data (e.g. speed, torque, pressure etc.)	38-40
Max. permissible shaft seal pressure.....	41
Pressure drop in motor, oil flow in drain line, direction of shaft rotation	42
Permissible shaft loads	43-44
Function diagrams	45-49
Shaft version	50-53
Port thread versions.....	54
Dimensions	55
Dimensions	55-65
OMH	66
Version.....	66
Code number	67
Technical data	68-80
Technical data (e.g. speed, torque, pressure etc.)	68-70
Max. permissible shaft seal pressure.....	71
Pressure drop in motor, oil flow in drain line, direction of shaft rotation	72
Permissible shaft loads	73
Function diagrams	74-76
Shaft version	77-79
Port thread versions.....	80
Dimensions	81
Dimensions	81-82



OMP, OMR, OMH and OMEW
Hydraulic Motor
Contents

CONTENTS

	Page
OMEW	84
Version.....	84
Code number	85
Technical data	86-94
Technical data (e.g. speed, torque, pressure etc.)	86
Max. permissible shaft seal pressure.....	87
Pressure drop in motor, direction of shaft rotation	88
Permissible shaft loads	89
Function diagrams	90-92
Shaft version.....	93
Port thread versions.....	94
Dimensions	95
Dimensions	95-96
Weight of motors	97-99

SPEED, TORQUE AND OUTPUT

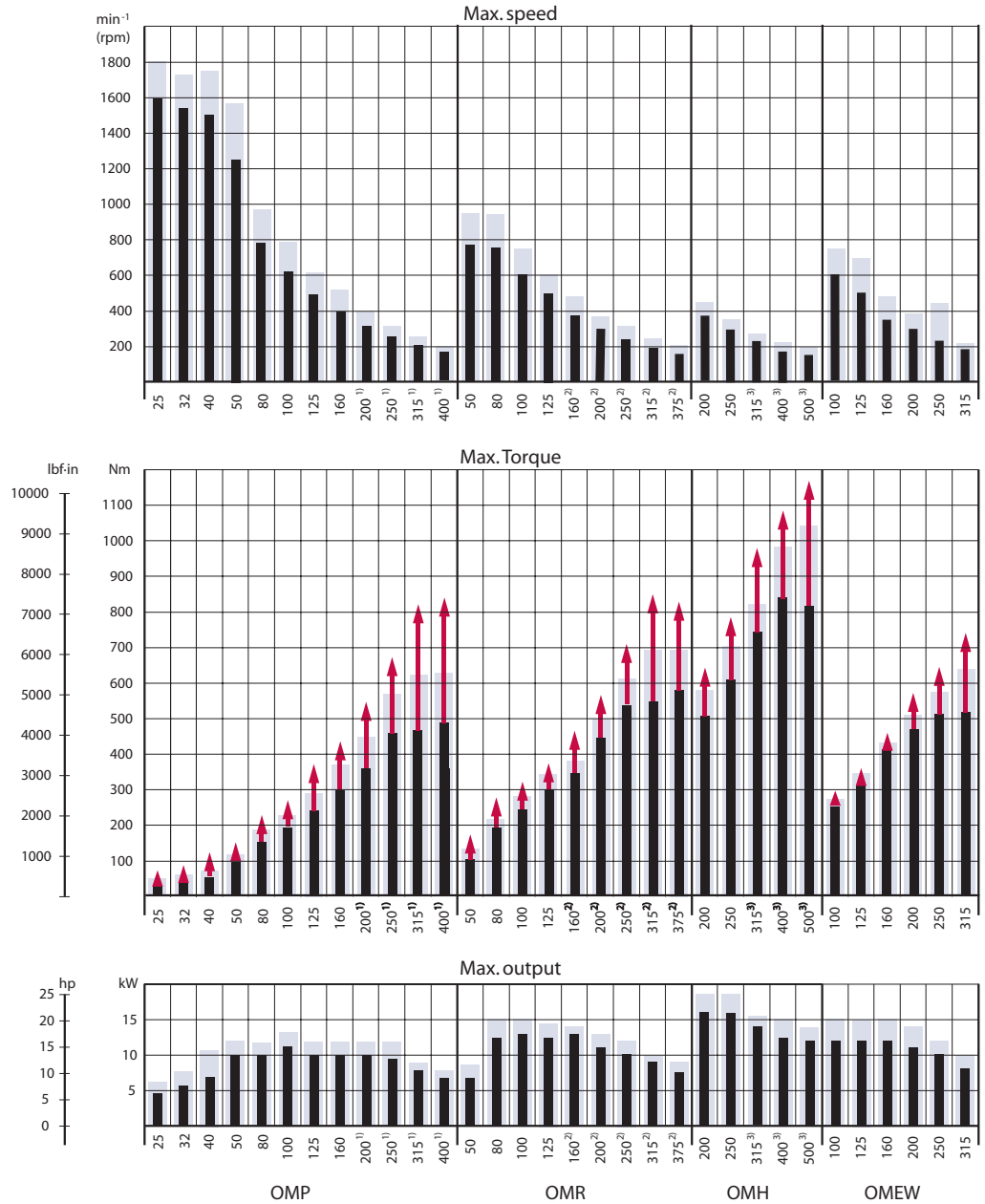

Peak values ↑ Intermittend values █ Continuous values █

151-1410.10

- 1) $\varnothing 1\frac{1}{4}$ in shaft
- 2) $\varnothing 1\frac{1}{4}$ in or $1\frac{1}{4}$ in tapered shaft
- 3) $1\frac{1}{4}$ in splined shaft



OMP, OMR, OMH and OMEW Hydraulic Motor Data survey

SPEED, TORQUE AND OUTPUT

The bar diagrams above are useful for a quick selection of relevant motor size for the application. The final motor size can be determined by using the function diagram for each motor size.

- OMP and OMPW can be found on pages 18 - 23
- OMR and OMRW can be found on pages 45 - 49
- OMH can be found on pages 74 - 76
- OMEW can be found on pages 90 - 92

The function diagrams are based on actual tests on a representative number of motors from our production. The diagrams apply to a return pressure between 5 and 10 bar (75 and 150 psi) when using mineral based hydraulic oil with a viscosity of 35 mm²/s (165 SUS) and a temperature of 50°C (120°F). For further explanation concerning how to read and use the function diagrams, please consult the paragraph "Selection of motor size" in the technical information "General" DHMH.PK.100.G2.02 520L0232.

VERSIONS

Mounting flange	Shaft	Port size	European version	US version	Side port version	End port version	Flange port version	Standard shaft seal	High pressure shaft seal	Drain connection	Check valve	Specials	Main type designation
2 hole oval flange (A2-flange)	Cyl. 25 mm	G 1/2	X		X				X	No	No		OMP
		G 1/2	X		X				X	Yes	No		OMP
		G 1/2	X		X			X		Yes	Yes	A	OMP C
		G 1/2	X			X		X		Yes	Yes		OMP
	Cyl. 1 in	G 1/2	X		X				X	No	No		OMP
		G 1/2	X		X				X	Yes	No		OMP
		7/8 - 14 UNF		X	X			X		Yes	Yes		OMP
	Splined 1 in	G 1/2	X		X				X	No	No		OMP
G 1/2		X		X				X	Yes	No		OMP	
4 hole oval flange (A4 flange)	Cyl. 32 mm	G 1/2	X		X			X		Yes	Yes		OMP
Square flange (C-flange)	Cyl. 25 mm	G 1/2	X			X		X		Yes	Yes		OMP
	Cyl. 1 in	7/8 - 14 UNF		X	X			X		Yes	Yes		OMP
		1/2 - 14 NPTF		X	X			X		Yes	Yes		OMP
Wheel	Cyl. 25 mm	G 1/2	X				X	X		Yes	Yes		OMPW
	Tap. 28.5 mm	G 1/2	X				X	X		Yes	Yes	B	OMPW N

Function diagram – see page : →

Specials:

- A : Corrosion resistant parts
- B : With needle bearings

Features available (options) :

- Free running gerotor
- Low leakage (low speed valve)
- Speed sensor
- Viton shaft seal
- Reverse rotation
- Drain
- Corrosion protected
- Painted
- With needle bearings

CODE NUMBERS

CODE NUMBERS	DISPLACEMENT [cm ³]												Technical data – Page	Dimensions – Page
	25	32	40	50	80	100	125	160	200	250	315	400		
151-	0340	0341	0342	0310	0311	0312	0313	0314	0315	0316	0317	0318	10	27
151-	0640	0641	0642	0610	0611	0612	0613	0614	0615	0616	0617	0618	10	28
151-	-	-	-	1208	1209	1210	1217	1211	1212	1213	1214	1215	10	29
151-	-	-	-	5191	5192	5193	5194	5195	5196	5197	5198	5199	10	30
151-	-	-	-	0300	0301	0302	0303	0304	0305	0306	0307	0308	10	27
151-	-	-	-	0600	0601	0602	0603	0604	0605	0606	0607	0608	10	28
151-	7080	7081	7082	7041	7042	7043	7044 ¹⁾	7045	7046	7047	7048	7049	10	31
151-	-	-	-	0330	0331	0332	0333	0334	0335	0336	0337	0338	11	27
151-	-	-	-	0630	0631	0632	0633	0634	0635	0636	0637	0638	11	28
151-	-	-	-	5001	5002	5003	5004	5005	5006	5007	5008	5009	12	32
151-	-	-	-	5211	5212	5213	5214	5215	5216	5217	5218	5219	10	33
151-	-	-	-	7061	7062	7063	5174	7065	7066	7067	7068	7069	10	34
151-	-	-	-	7021	7022	7023	7024	7025	7026	7027	7028	7029	10	34
151-	-	-	-	7101	7102	7103	7104	7105	7106	7107	7108	7109	10	35
151-	-	-	-	5301	5302	5303	5304	5305	5306	5307	5308	5309	11	35
	18	18	19	19	20	20	21	21	22	22	23	23		

1) Motor is painted black

Ordering

Add the four digit prefix "151-" to the four digit numbers from the chart for complete code number.

Example:

151-0305 for an OMP 200 with A2 flange, cyl. 1 in shaft, port size G 1/2 and high pressure shaft seal.

Note: Orders will not be accepted without the four digit prefix.

TECHNICAL DATA FOR OMP/OMPW WITH 25 MM AND 1 IN CYLINDRICAL SHAFT

Type		OMP	OMP	OMP	OMP	OMP	OMP	OMP	OMP	OMP	OMP	OMP	OMP	
Motor size		25	32	40	50	80	100	125	160	200	250	315	400	
Geometric displacement	cm ³ (in ³)	25.0 (1.53)	32.0 (1.96)	40.0 (2.45)	48.6 (2.97)	77.8 (4.76)	97.3 (5.95)	125.0 (7.65)	155.7 (9.53)	194.6 (11.91)	242.3 (14.83)	306.1 (18.73)	389.2 (23.82)	
Max. speed	min ⁻¹ (rpm)	cont.	1600	1560	1500	1230	770	615	480	385	310	250	195	155
		int. ¹⁾	1800	1720	1750	1540	960	770	600	480	385	310	245	190
Max. torque	Nm (lbf-in)	cont.	33 (290)	43 (380)	52 (460)	93 (820)	150 (1330)	190 (1680)	240 (2120)	300 (2660)	300 (2660)	300 (2660)	300 (2660)	300 (2660)
		int. ¹⁾	47 (420)	61 (540)	74 (660)	120 (1060)	190 (1680)	230 (2040)	290 (2570)	370 (3280)	380 (3360)	410 (3630)	390 (3450)	420 (3720)
		peak ²⁾	67 (590)	86 (760)	107 (950)	140 (1240)	220 (1950)	270 (2390)	370 (3280)	430 (3810)	540 (4780)	550 (4870)	600 (5310)	600 (5310)
Max. output	kW (hp)	cont.	4.5 (6.0)	5.8 (7.8)	7.0 (9.4)	10.0 (13.4)	10.0 (13.4)	11.0 (14.8)	10.0 (13.4)	10.0 (13.4)	8.0 (10.7)	6.0 (8.1)	5.0 (6.7)	4.0 (5.4)
		int. ¹⁾	6.1 (8.2)	7.8 (10.5)	10.6 (14.2)	12.0 (16.1)	12.0 (16.1)	13.0 (17.4)	12.0 (16.1)	12.0 (16.1)	11.0 (14.8)	9.0 (12.1)	7.0 (9.4)	6.0 (8.1)
Max. pressure drop	bar (psi)	cont.	100 (1450)	100 (1450)	100 (1450)	140 (2030)	140 (2030)	140 (2030)	140 (2030)	140 (2030)	115 (1670)	90 (1310)	75 (1090)	60 (870)
		int. ¹⁾	140 (2030)	140 (2030)	140 (2030)	175 (2540)	175 (2540)	175 (2540)	175 (2540)	175 (2540)	150 (2180)	125 (1810)	100 (1450)	80 (1160)
		peak ²⁾	225 (3260)	225 (3260)	225 (3260)	225 (3260)	225 (3260)	225 (3260)	225 (3260)	225 (3260)	225 (3260)	225 (3260)	180 (2610)	160 (2320)
Max. oil flow	l/min (USgal/min)	cont.	40 (10.6)	50 (13.2)	60 (15.9)	60 (15.9)	60 (15.9)	60 (15.9)	60 (15.9)	60 (15.9)	60 (15.9)	60 (15.9)	60 (15.9)	60 (15.9)
		int. ¹⁾	45 (11.9)	55 (14.5)	70 (18.5)	75 (19.8)	75 (19.8)	75 (19.8)	75 (19.8)	75 (19.8)	75 (19.8)	75 (19.8)	75 (19.8)	75 (19.8)
Max. starting pressure with unloaded shaft	bar (psi)	10 (145)	10 (145)	10 (145)	10 (145)	10 (145)	10 (145)	9 (130)	7 (100)	5 (75)	5 (75)	5 (75)	5 (75)	
Min. starting torque	at max. press. drop cont.	30 (270)	40 (350)	45 (400)	80 (710)	135 (1200)	170 (1510)	210 (1860)	280 (2480)	270 (2390)	280 (2480)	280 (2480)	280 (2480)	
	at max. press. drop int. ¹⁾	40 (350)	55 (490)	63 (560)	100 (890)	170 (1510)	210 (1860)	270 (2390)	350 (3100)	360 (3190)	390 (3450)	370 (3280)	400 (3540)	
Min. speed ³⁾	min ⁻¹ (rpm)	20	15	10	10	10	9	9	8	7	5	5	5	

¹⁾ Intermittent operation: the permissible values may occur for max. 10% of every minute.

²⁾ Peak load: the permissible values may occur for max. 1% of every minute.

³⁾ Operation at lower speeds may be slightly less smooth.

TECHNICAL DATA FOR OMP/OMPW WITH 1 IN SPLINED AND 28,5 MM TAPERED SHAFT

Type		OMP	OMP	OMP	OMP	OMP	OMP	OMP	OMP	OMP	
Motor size		50	80	100	125	160	200	250	315	400	
Geometric displacement	cm ³ (in ³)	48.6 (2.97)	77.8 (4.76)	97.3 (5.95)	125.0 (7.65)	155.7 (9.53)	194.6 (11.91)	242.3 (14.83)	306.1 (18.73)	389.2 (23.82)	
Max. speed	min ⁻¹ (rpm)	cont.	1230	770	615	480	385	310	250	195	155
		int. ¹⁾	1540	960	770	600	480	385	310	245	190
Max. torque	Nm (lbf-in)	cont.	93 (820)	150 (1330)	190 (1680)	240 (2120)	300 (2660)	360 (3190)	360 (3190)	360 (3190)	360 (3190)
		int. ¹⁾	120 (1060)	190 (1680)	230 (2040)	290 (2570)	370 (3280)	450 (3980)	460 (4070)	470 (4160)	460 (4070)
		peak ²⁾	140 (1240)	220 (1950)	270 (2390)	370 (3280)	430 (3810)	540 (4780)	550 (4870)	540 (4780)	560 (4960)
Max. output	kW (hp)	cont.	10.0 (13.4)	10.0 (13.4)	11.0 (14.8)	10.0 (13.4)	10.0 (13.4)	10.0 (13.4)	8.0 (10.7)	6.0 (8.0)	5.0 (6.7)
		int. ¹⁾	12.0 (16.1)	12.0 (16.1)	13.0 (17.4)	12.0 (16.1)	12.0 (16.1)	12.0 (16.1)	10.5 (14.1)	7.5 (10.1)	6.0 (8.0)
Max. pressure drop	bar (psi)	cont.	140 (2030)	140 (2030)	140 (2030)	140 (2030)	140 (2030)	140 (2030)	105 (1520)	90 (1310)	70 (1020)
		int. ¹⁾	175 (2540)	175 (2540)	175 (2540)	175 (2540)	175 (2540)	175 (2540)	140 (2030)	120 (1740)	90 (1310)
		peak ²⁾	225 (3260)	225 (3260)	225 (3260)	225 (3260)	225 (3260)	225 (3260)	180 (2610)	160 (2320)	130 (1890)
Max. oil flow	l/min (USgal/min)	cont.	60 (15.9)	60 (15.9)	60 (15.9)	60 (15.9)	60 (15.9)	60 (15.9)	60 (15.9)	60 (15.9)	60 (15.9)
		int. ¹⁾	75 (19.8)	75 (19.8)	75 (19.8)	75 (19.8)	75 (19.8)	75 (19.8)	75 (19.8)	75 (19.8)	75 (19.8)
Max. starting pressure with unloaded shaft	bar (psi)	10 (145)	10 (145)	10 (145)	9 (130)	7 (100)	5 (75)	5 (75)	5 (75)	5 (75)	
Min. starting torque	at max. press. drop cont.	80 (710)	135 (1200)	170 (1510)	210 (1860)	280 (2480)	340 (3010)	330 (2920)	340 (3010)	345 (3050)	
	at max. press. drop int. ¹⁾	100 (890)	170 (1510)	210 (1860)	270 (2390)	350 (3100)	420 (3720)	440 (3890)	450 (3980)	425 (3760)	
Min. speed ³⁾	min ⁻¹ (rpm)	10	10	9	9	8	7	5	5	5	

¹⁾ Intermittent operation: the permissible values may occur for max. 10% of every minute.

²⁾ Peak load: the permissible values may occur for max. 1% of every minute.

³⁾ Operation at lower speeds may be slightly less smooth.

TECHNICAL DATA FOR OMP/OMPW WITH 32 MM CYLINDRICAL SHAFT

Type		OMP	OMP	OMP	OMP	OMP	OMP	OMP	OMP	OMP	
Motor size		50	80	100	125	160	200	250	315	400	
Geometric displacement	cm ³ (in ³)	48.6 (2.97)	77.8 (4.76)	97.3 (5.95)	125.0 (7.65)	155.7 (9.53)	194.6 (11.91)	242.3 (14.83)	306.1 (18.73)	389.2 (23.82)	
Max. speed	min ⁻¹ (rpm)	cont.	1230	770	615	480	385	310	250	195	155
		int. ¹⁾	1540	960	770	600	480	385	310	245	190
Max. torque	Nm (lbf-in)	cont.	93 (820)	150 (1330)	190 (1680)	240 (2120)	300 (2660)	360 (3190)	460 (4070)	470 (4160)	490 (4340)
		int. ¹⁾	120 (1060)	190 (1680)	230 (2040)	290 (2570)	370 (3280)	450 (3980)	570 (5050)	620 (5490)	630 (5580)
		peak ²⁾	140 (1240)	220 (1950)	270 (2390)	370 (3280)	430 (3810)	540 (4780)	670 (5930)	820 (7260)	840 (7440)
Max. output	kW (hp)	cont.	10.0 (13.4)	10.0 (13.4)	11.0 (14.8)	10.0 (13.4)	10.0 (13.4)	10.0 (13.4)	9.5 (12.7)	7.5 (10.1)	6.5 (8.7)
		int. ¹⁾	12.0 (16.1)	12.0 (16.1)	13.0 (17.4)	12.0 (16.1)	12.0 (16.1)	12.0 (16.1)	12.0 (16.1)	9.0 (12.1)	7.5 (10.1)
Max. pressure drop	bar (psi)	cont.	140 (2030)	140 (2030)	140 (2030)	140 (2030)	140 (2030)	140 (2030)	140 (2030)	120 (1741)	95 (1380)
		int. ¹⁾	175 (2540)	175 (2540)	175 (2540)	175 (2540)	175 (2540)	175 (2540)	175 (2540)	160 (2320)	125 (1810)
		peak ²⁾	225 (3260)	225 (3260)	225 (3260)	225 (3260)	225 (3260)	225 (3260)	225 (3260)	225 (3260)	180 (2610)
Max. oil flow	l/min (USgal/min)	cont.	60 (15.9)	60 (15.9)	60 (15.9)	60 (15.9)	60 (15.9)	60 (15.9)	60 (15.9)	60 (15.9)	60 (15.9)
		int. ¹⁾	75 (19.8)	75 (19.8)	75 (19.8)	75 (19.8)	75 (19.8)	75 (19.8)	75 (19.8)	75 (19.8)	75 (19.8)
Max. starting pressure with unloaded shaft	bar (psi)	10 (145)	10 (145)	10 (145)	9 (130)	7 (100)	5 (75)	5 (75)	5 (75)	5 (75)	
Min. starting torque	at max. press. drop cont.	80 (710)	135 (1200)	170 (1510)	210 (1860)	280 (2480)	340 (3010)	420 (3720)	460 (4070)	460 (4070)	
	at max. press. drop int. ¹⁾	100 (890)	170 (1510)	210 (1860)	270 (2390)	350 (3100)	420 (3720)	530 (4690)	600 (5310)	600 (5310)	
	Nm (lbf-in)										
Min. speed ³⁾	min ⁻¹ (rpm)	10	10	9	9	8	7	5	5	5	

Type		Max. inlet pressure	Max. return pressure with drain line
OMP 25 - 400	bar (psi) cont.	175 (2540)	175 (2540)
	bar (psi) int. ¹⁾	200 (2900)	200 (2900)
	bar (psi) peak ²⁾	225 (3260)	225 (3260)

¹⁾ Intermittent operation: the permissible values may occur for max. 10% of every minute.

²⁾ Peak load: the permissible values may occur for max. 1% of every minute.

³⁾ Operation at lower speeds may be slightly less smooth.

OMP WITH HIGH PRESSURE SHAFT SEAL (HPS)

OMP with HPS and without drain connection:
The shaft seal pressure equals the average of input pressure and return pressure.

$$P_{\text{seal}} = \frac{P_{\text{in}} + P_{\text{return}}}{2}$$

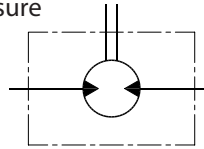

151-1743.10

OMP with HPS and drain connection:
The shaft seal pressure equals the pressure in the drain line.

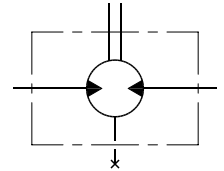

151-1855.10

Max. permissible shaft seal pressure

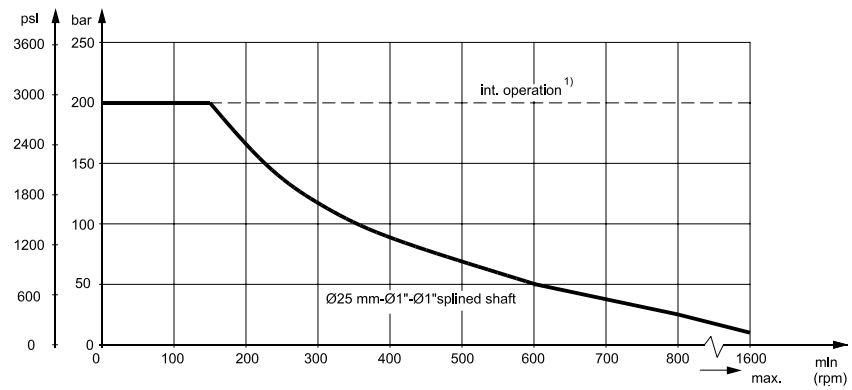

151-1745.10

OMP WITH STANDARD SHAFT SEAL

OMP with standard shaft seal, check valves and without use of drain connection:
The pressure on the shaft seal never exceeds the pressure in the return line

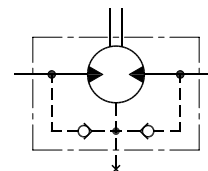

151-320.10

OMP with standard shaft seal, check valves and with drain connection:
The shaft seal pressure equals the pressure on the drain line.

Max. return pressure without drain line or max. pressure in the drain line

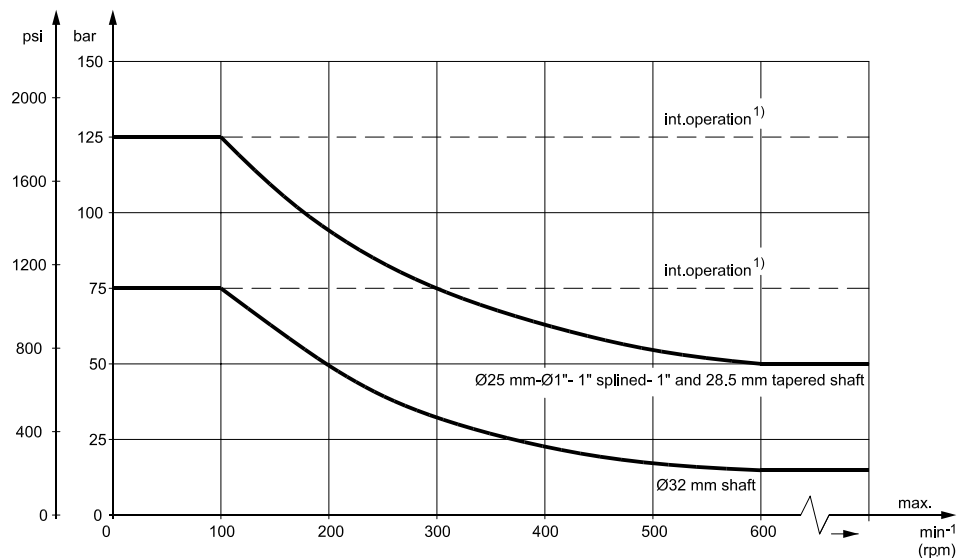

151-1563.10

¹⁾ Intermittent operation: the permissible values may occur for max. 10% of every minute.

PRESSURE DROP IN MOTOR

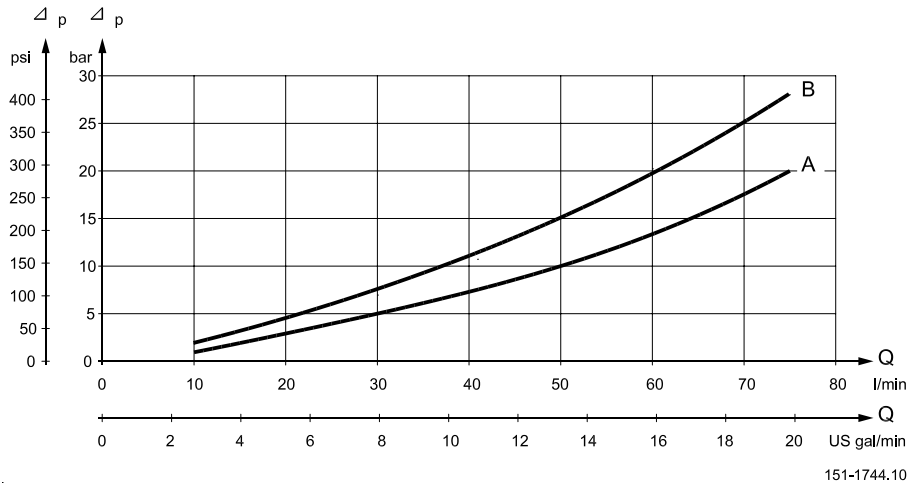

The curve applies to an unloaded motor shaft and an oil viscosity of 35 mm²/s (165 SUS)

A: OMP 50 - 400
B: OMP 25 - 40 / OMPW

OIL FLOW IN DRAIN LINE

The table shows the max. oil flow in the drain line at a return pressure less than 5-10 bar (75-150 psi).

Pressure drop bar (psi)	Viscosity mm ² /s (SUS)	Oil flow in drain line l/min (US gal/min)
100 (1450)	20 (100)	2.5 (0.66)
	35 (165)	1.8 (0.78)
140 (2030)	20 (100)	3.5 (0.93)
	35 (165)	2.8 (0.74)

DIRECTION OF SHAFT ROTATION

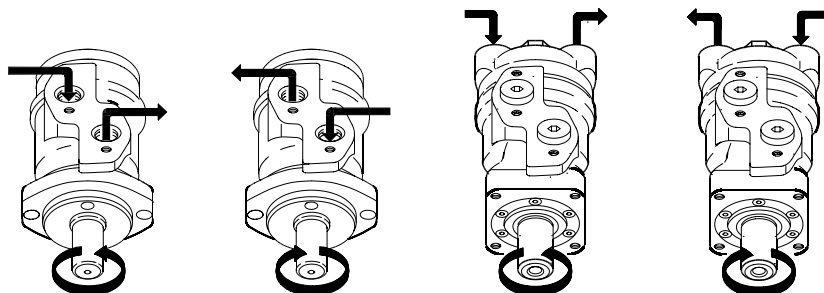

151-1836.10

PERMISSIBLE SHAFT LOADS FOR OMP

The permissible radial shaft load (P_R) depends on

- speed (n)
- distance (l) from the point of load to the mounting flange
- mounting flange version
- shaft version

Mounting flange	4-hole oval flange** 2-hole oval flange (European version)	4-hole oval flange	Square flange** 2-hole oval flange (US version)
Shaft version	25 mm cylindrical shaft 1 in cylindrical shaft 1 in splined shaft	32 mm cylindrical shaft	25 mm cylindrical shaft
Permissible shaft load (P_R) l in mm	$\frac{800}{n} \times \frac{250000}{95+l} \text{ N}^*$	$\frac{800}{n} \times \frac{187500}{95+l} \text{ N}^*$	$\frac{800}{n} \times \frac{250000}{101+l} \text{ N}^*$
Permissible shaft load (P_R) l in inch	$\frac{800}{n} \times \frac{2215}{3.74+l} \text{ lbf}^*$	$\frac{800}{n} \times \frac{1660}{3.74+l} \text{ lbf}^*$	$\frac{800}{n} \times \frac{2215}{3.98+l} \text{ lbf}^*$

* $n \geq 200 \text{ min}^{-1} \text{ (rpm)}$; $l \leq 55 \text{ mm (2.2 in)}$
 $n < 200 \text{ min}^{-1} \text{ (rpm)}$; $\Rightarrow P_{Rmax} = 8000 \text{ N (1800 lbf)}$
 ** For both European and US version

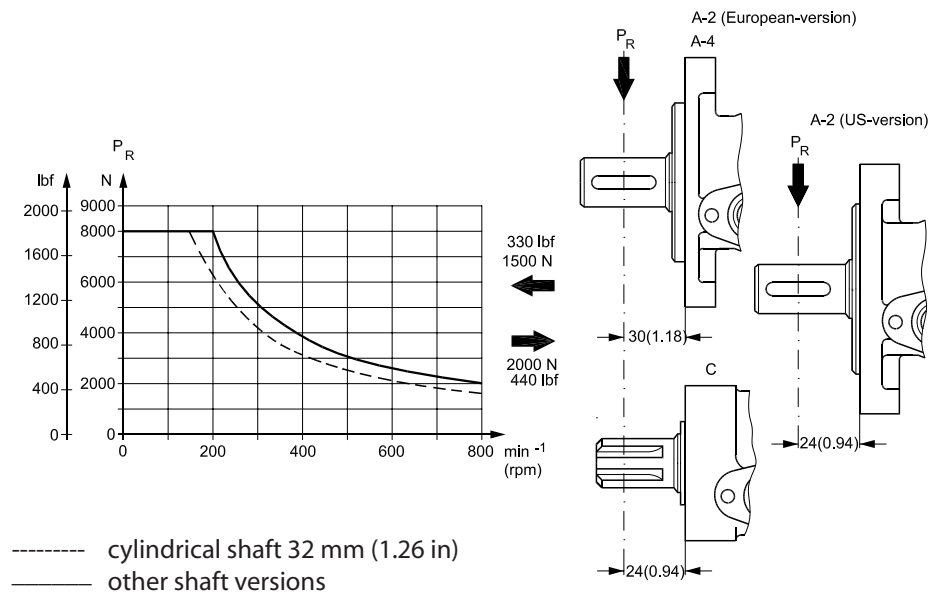

151-1203.10

The curve shows the relation between P_R and n

- when $l = 30 \text{ mm (1.18 in)}$ for motors with oval mounting flange
- when $l = 24 \text{ mm (0.94 in)}$ for motors with square mounting flange

For applications with special performance requirements we recommend OMP with the output shaft running in needle bearings.

**PERMISSIBLE SHAFT
LOAD FOR OMPW WITH
SLIDE BEARINGS**

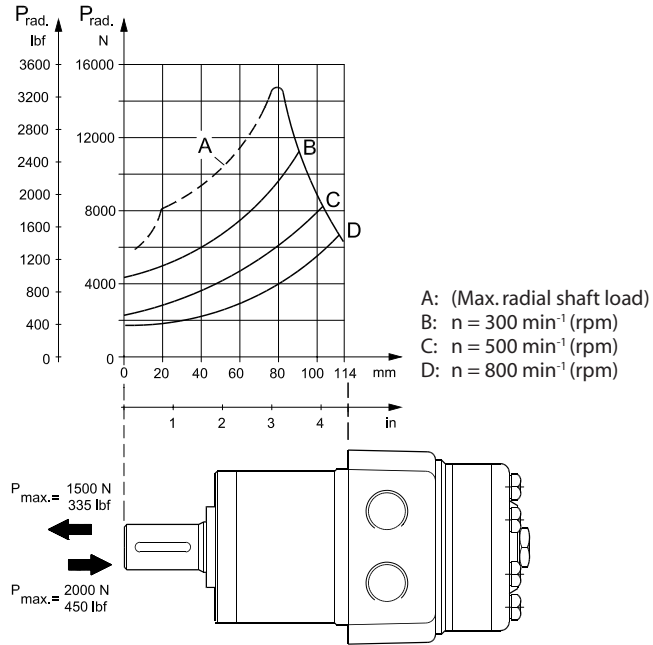

151-1389.10

The output shaft on OMPW can be offered in slide bearings similar to the other OMP-motors. The permissible higher radial load is therefore due to the recessed mounting flange moving the point of load closer to the motor bearings.

The permissible radial load on the shaft is shown for different speeds as a function of the distance from the mounting flange to the point of load application.

The curves are not based on calculations of B10 bearing life. They represent absolute limits that must not be exceeded.

Curve A indicates the max. radial shaft load. Any shaft load exceeding the values quoted in curve A will involve risk of breakage.

**PERMISSIBLE SHAFT
LOAD FOR OMPW N WITH
NEEDLE BEARING**

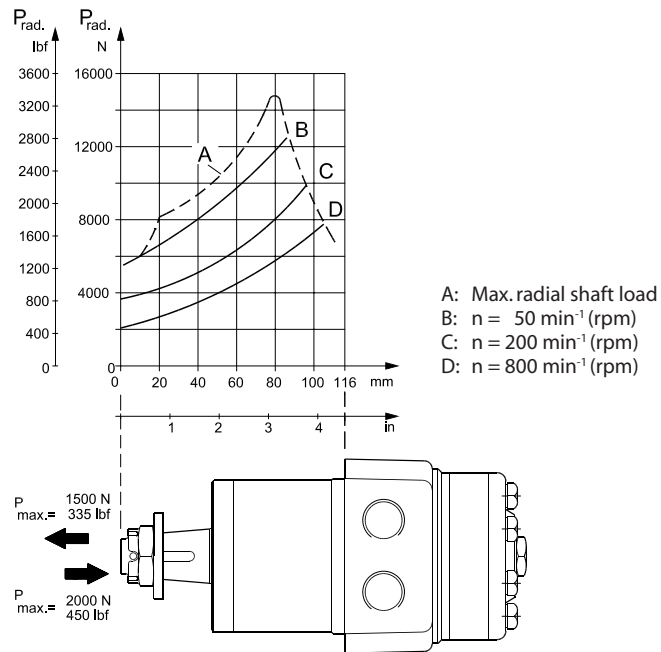

151-1387.10

The output shaft on OMPW N can be offered in needle bearings. These bearings and the recessed mounting flange allow a higher permissible radial load in comparison to OMP motors.

The permissible radial load on the shaft is shown for different speeds as a function of the distance from the mounting flange to the point of load application.

Curve A indicates the max. radial shaft load. Any shaft load exceeding the values quoted in curve A will involve risk of breakage.

The other curves apply to a B10 bearing life of 2000 hours at the number of revolutions indicated by the curve letter. Mineral based hydraulic oil with a sufficient content of anti-wear additives must be used.

Bearing life calculations can be made using the explanation and formula provided in the chapter "Bearing dimensioning" in the technical information "General" DHMH.PK.100.G2.02 520L0232.

FUNCTION DIAGRAMS

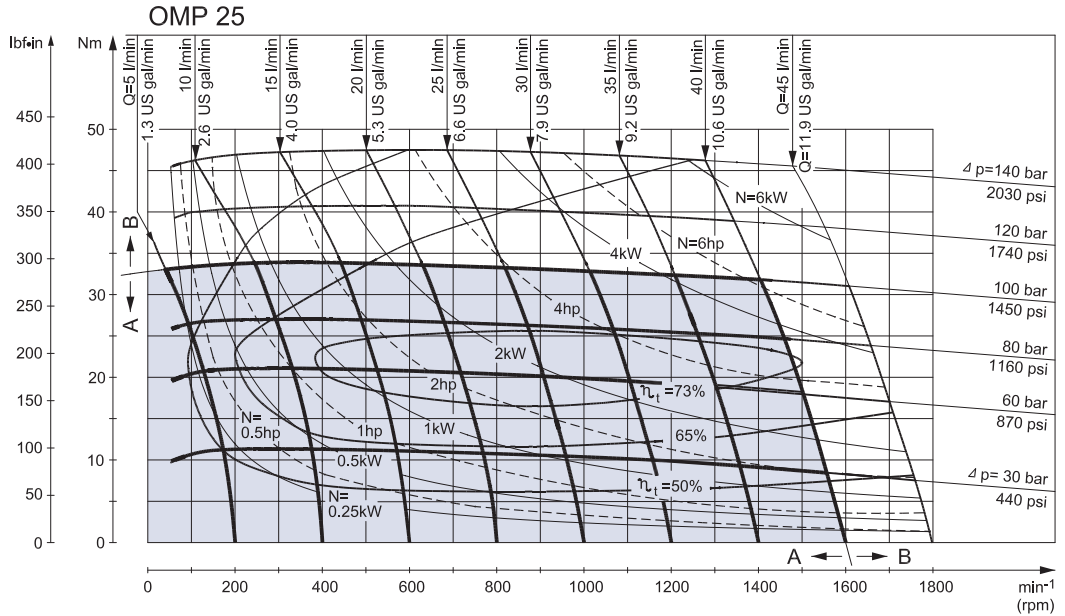

151-1369.10

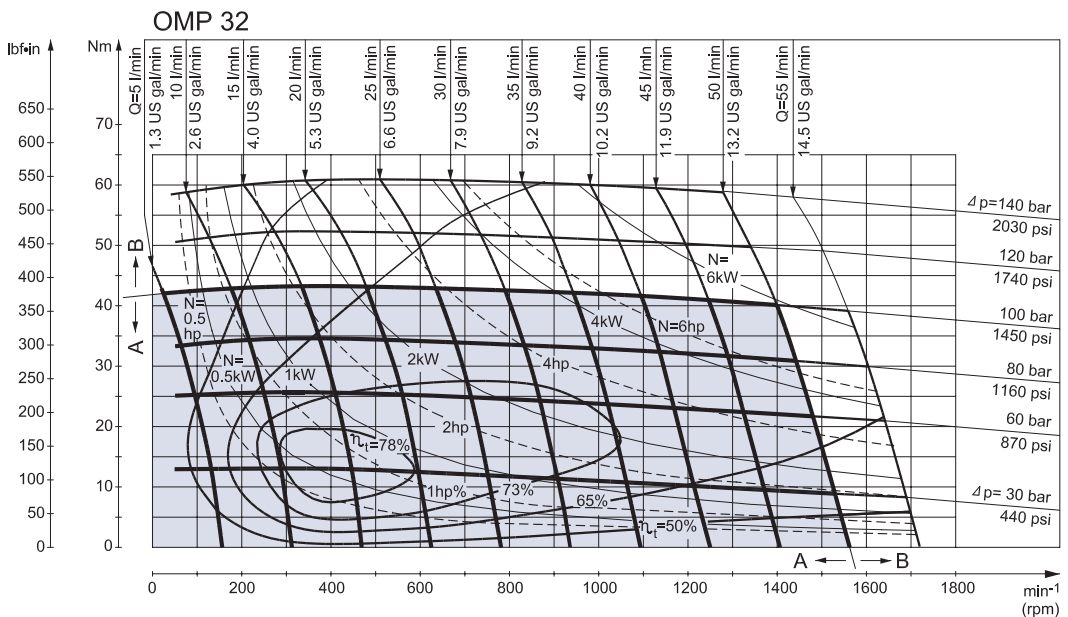

151-1383.10

Explanation of function diagram use, basis and conditions can be found on page 7.

- A: Continuous range
- B: Intermittent range (max. 10% operation every minute)

Max. permissible continuous/intermittent pressure drop for the actual shaft version can be found on page 10-12.

Note: Intermittent pressure drop and oil flow must not occur simultaneously.

FUNCTION DIAGRAMS

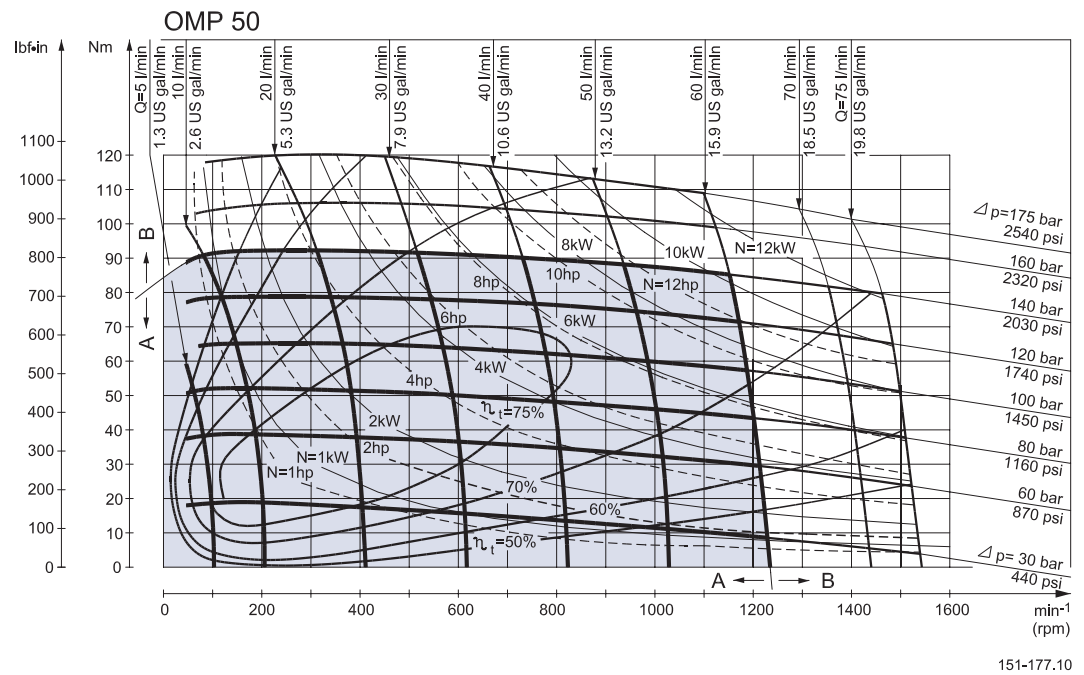
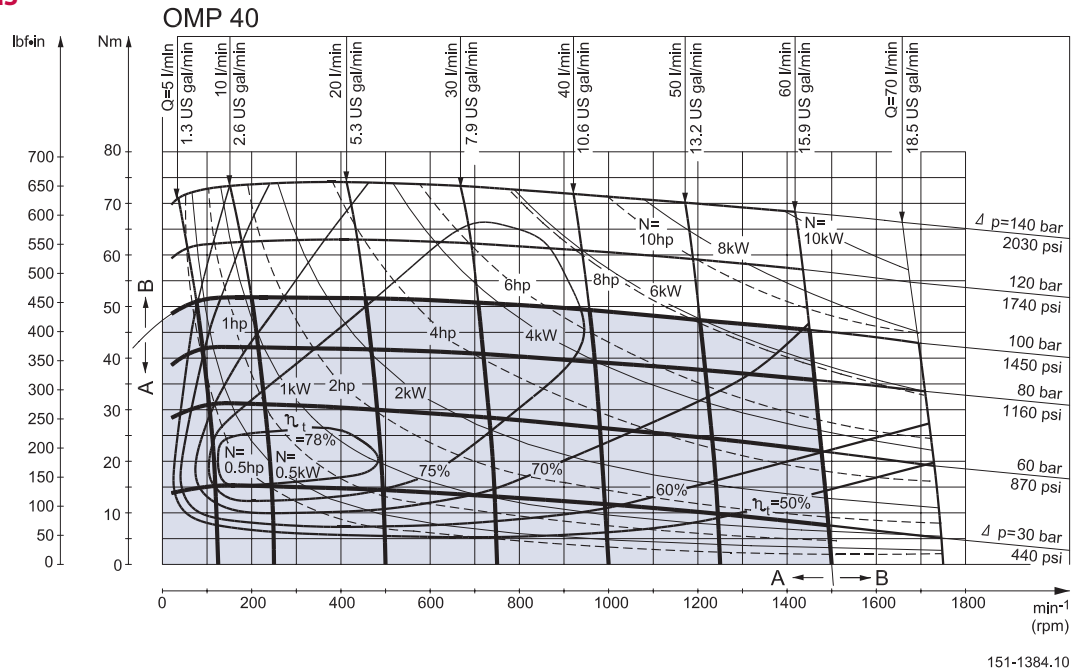

Explanation of function diagram use, basis and conditions can be found on page 7.

- A: Continuous range
- B: Intermittent range (max. 10% operation every minute)

Max. permissible continuous/intermittent pressure drop for the actual shaft version can be found on page 10-12.

Note: Intermittent pressure drop and oil flow must not occur simultaneously.

FUNCTION DIAGRAMS

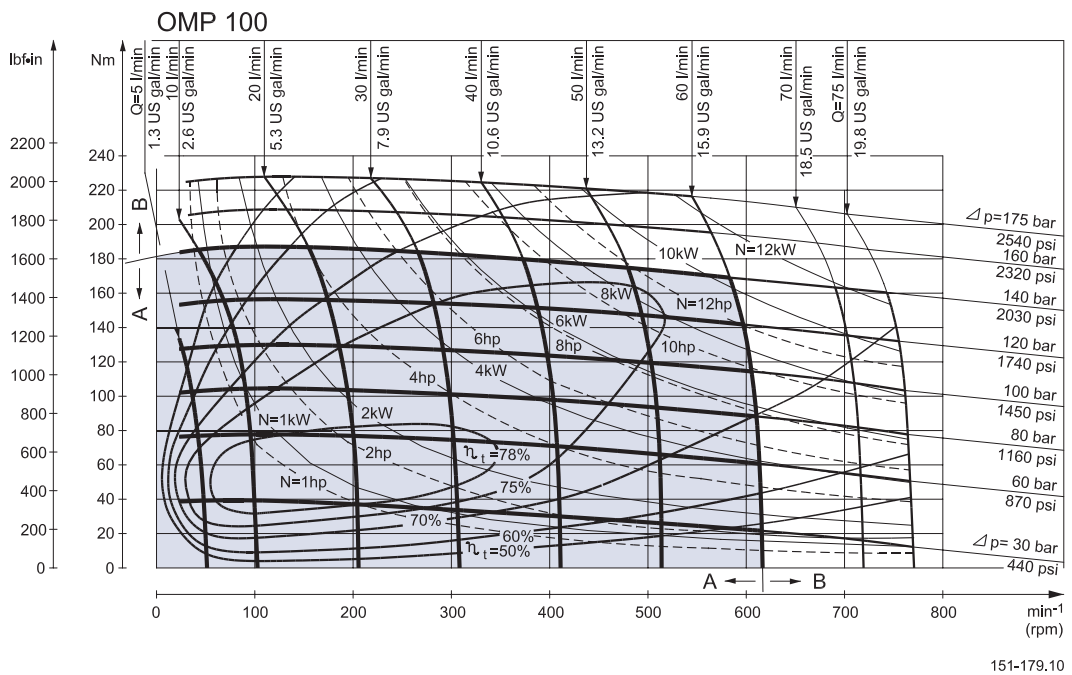
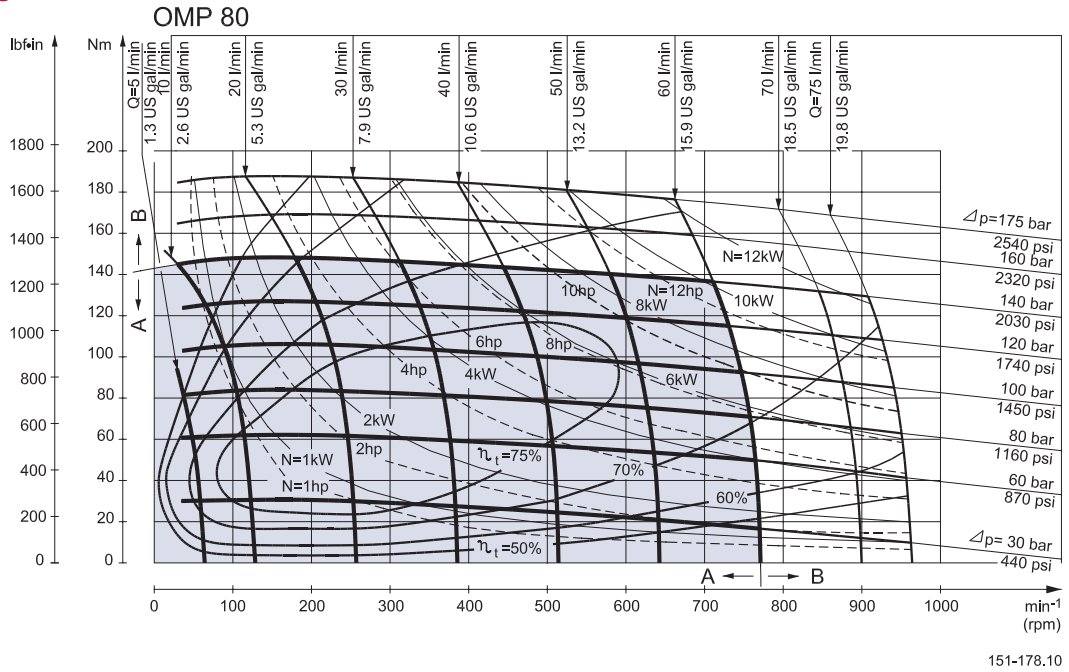

Explanation of function diagram use, basis and conditions can be found on page 7.

- A: Continuous range
- B: Intermittent range (max. 10% operation every minute)

Max. permissible continuous/intermittent pressure drop for the actual shaft version can be found on page 10-12.

Note: Intermittent pressure drop and oil flow must not occur simultaneously.

FUNCTION DIAGRAMS

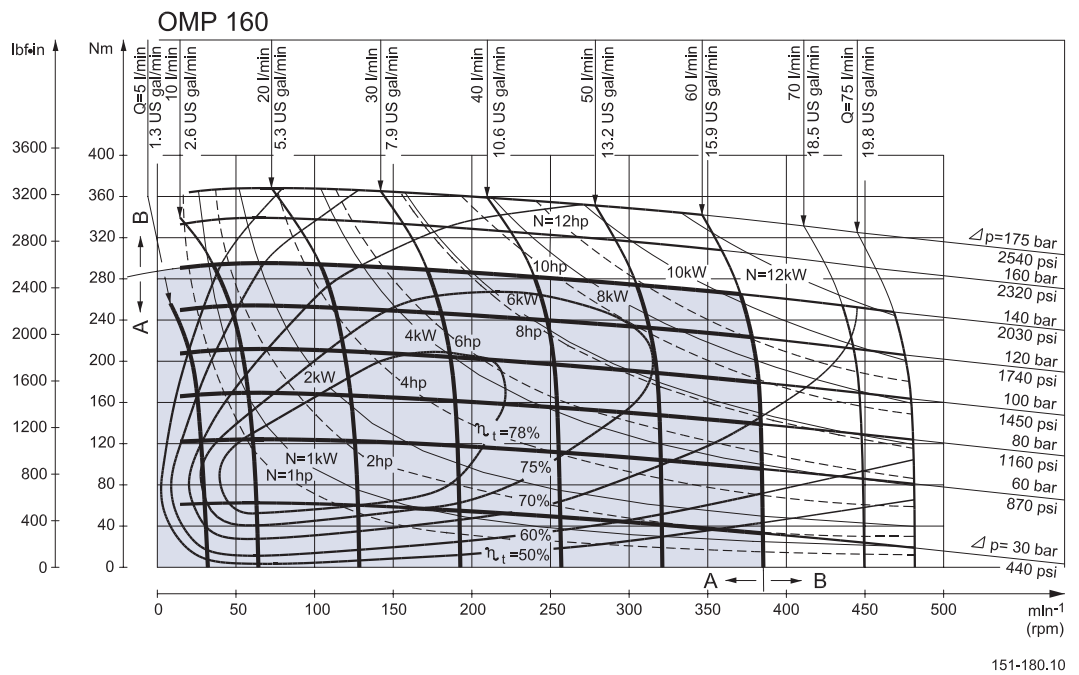
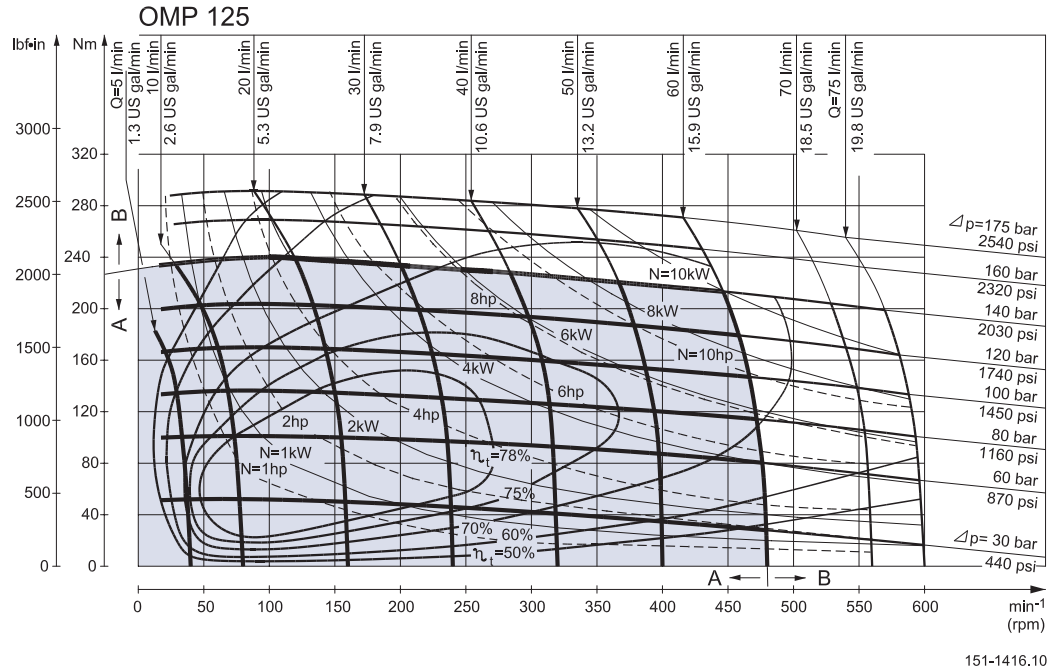

Explanation of function diagram use, basis and conditions can be found on page 7.

- A: Continuous range
- B: Intermittent range (max. 10% operation every minute)

Max. permissible continuous/intermittent pressure drop for the actual shaft version can be found on page 10-12.

Note: Intermittent pressure drop and oil flow must not occur simultaneously.

FUNCTION DIAGRAMS

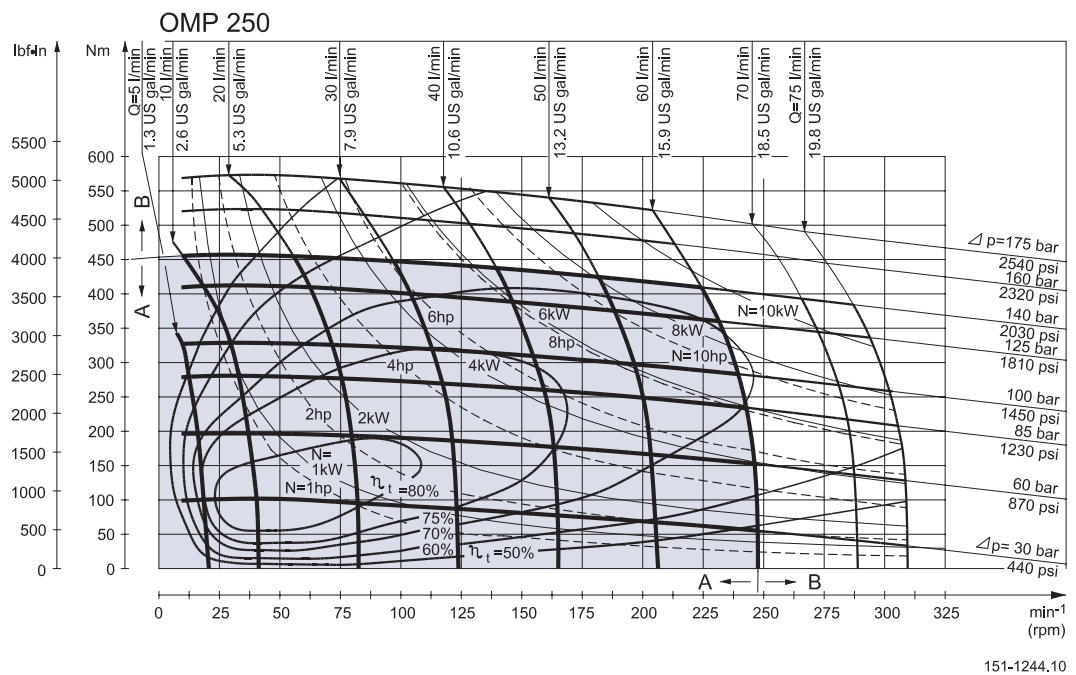
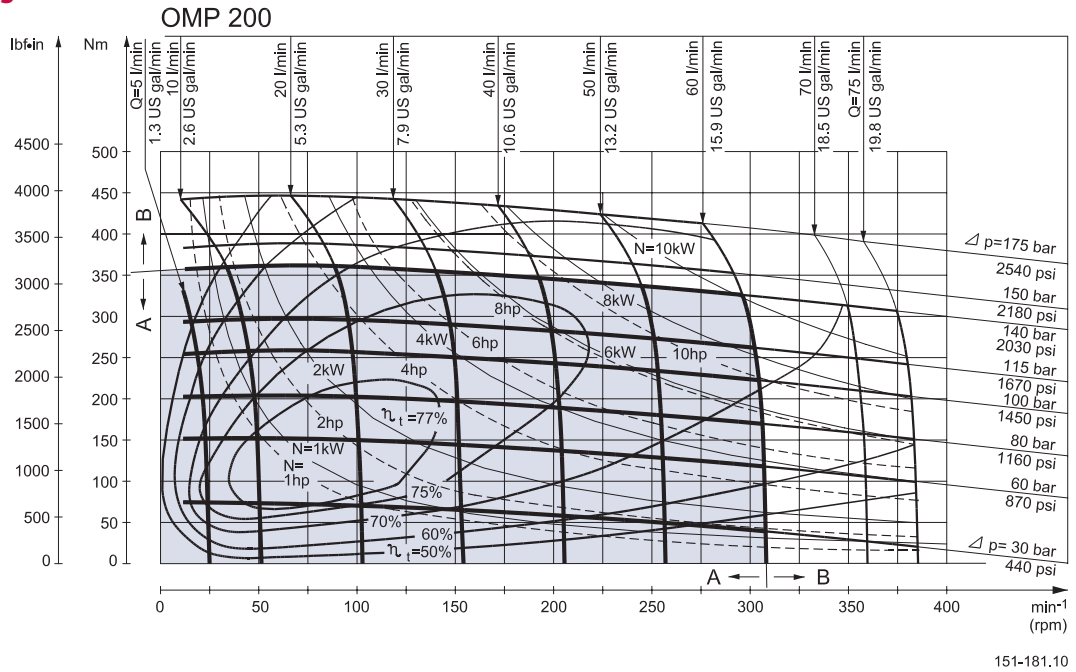

Explanation of function diagram use, basis and conditions can be found on page 7.

- A: Continuous range
- B: Intermittent range (max. 10% operation every minute)

Max. permissible continuous/intermittent pressure drop for the actual shaft version can be found on page 10-12.

Note: Intermittent pressure drop and oil flow must not occur simultaneously.

FUNCTION DIAGRAMS

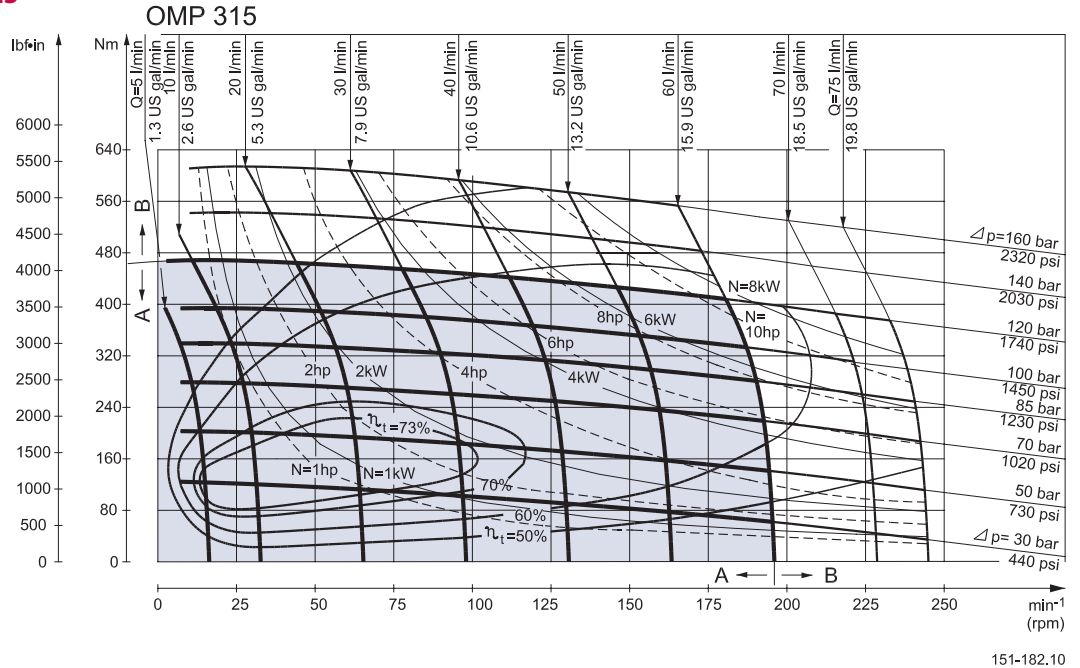

151-182.10

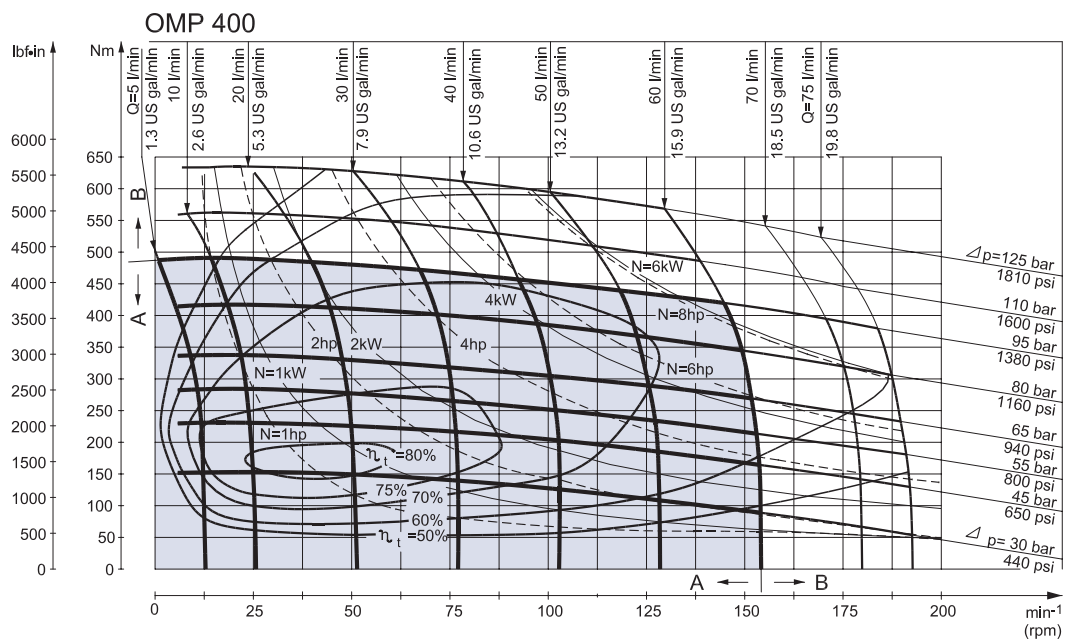

151-1161.10

Explanation of function diagram use, basis and conditions can be found on page 7.

- A: Continuous range
- B: Intermittent range (max. 10% operation every minute)

Max. permissible continuous/intermittent pressure drop for the actual shaft version can be found on page 10-12.

Note: Intermittent pressure drop and oil flow must not occur simultaneously.

SHAFT VERSION

A: Cylindrical shaft
25 mm
D: Parallel key
A8 × 7 × 32
DIN 6885

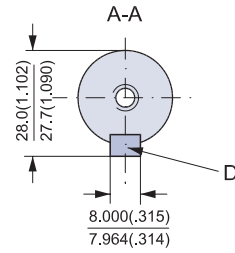
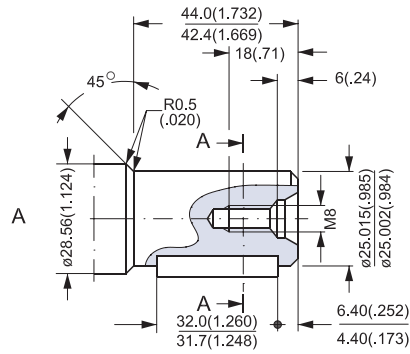

B: Cylindrical shaft
1 in
E: Parallel key
1/4 × 1/4 × 1 1/4 in
B.S. 46

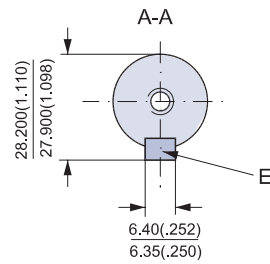
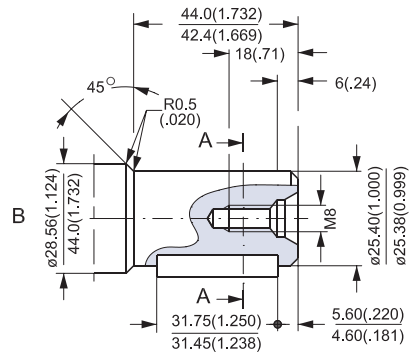

US version
C: Cylindrical shaft
1 in
F: Parallel key
1/4 × 1/4 × 1 1/4 in
B.S. 46

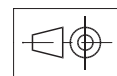
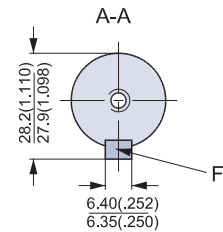
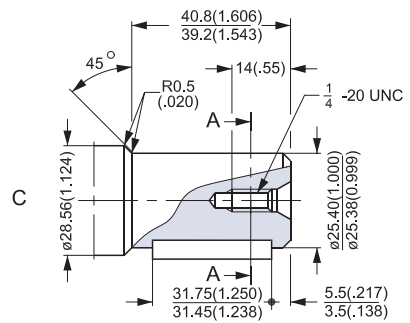

151-1842.10

SHAFT VERSION

D: Cylindrical shaft
32 mm
I: Parallel key
A10 × 8 × 45
DIN 6885

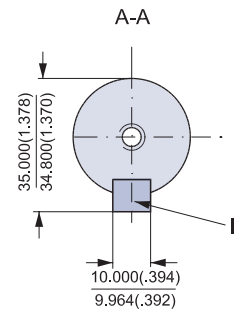
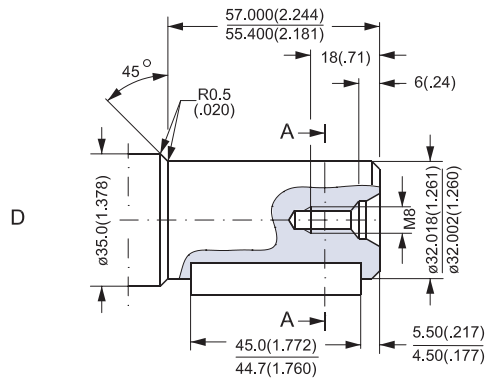

E: Splined shaft
B.S. 2059 (SAE 6 B)
Straight-sided,
bottom fitting, dep.
Fit 2
Nom. size 1 in
* Deviates from
BS 2059 (SAE 6B)

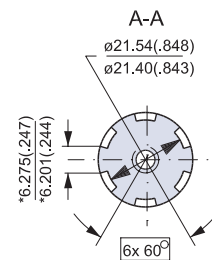
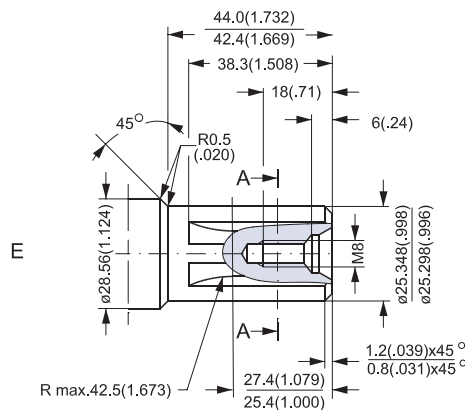

F: Tapered shaft
(ISO/R775) →
H: DIN 937
NV 30
Tightening torque:
100 ± 10 Nm
G: Taper 1:10
J: Parallel key
B5 × 5 × 14
DIN 6885

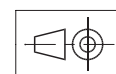
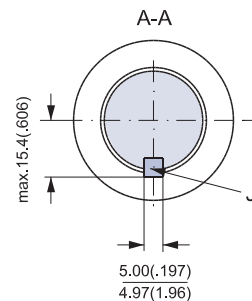
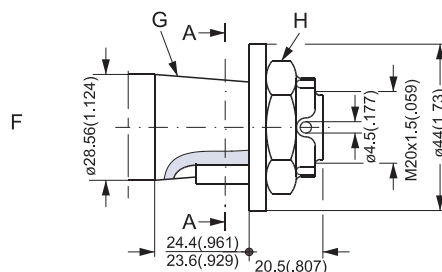

151-1843.10

PORT THREAD VERSIONS

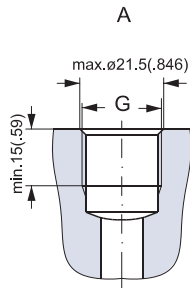

A: G main ports
G: ISO 228/1 - G¹/₂

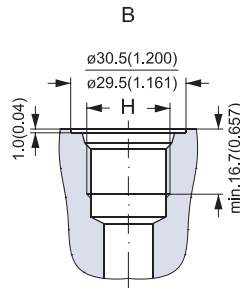

B: UNF main ports
H: ⁷/₈ - 14 UNF
O-ring boss port

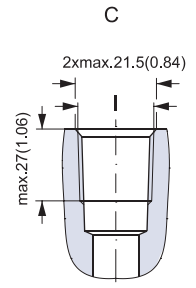

C: NPTF main ports
I: ¹/₂ - 14 NPTF

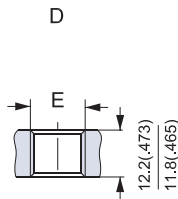

D: G drain port
E: ISO 228/1 - G¹/₄

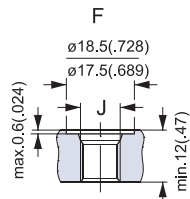

F: UNF drain port
J: ⁷/₁₆ - 20 UNF
O-ring boss port

151-1844.10

DIMENSIONS

Side port version with 2 hole oval mounting flange (A2-flange).

Type	L mm (in)	L ₁ mm (in)
OMP 25	129.0 (5.08)	4.1 (0.16)
OMP 32	130.0 (5.12)	5.2 (0.20)
OMP 40	131.0 (5.16)	6.5 (0.26)
OMP 50	131.0 (5.16)	6.5 (0.26)
OMP 80	135.0 (5.31)	10.4 (0.41)
OMP 100	137.5 (5.41)	13.0 (0.51)
OMP 125	141.0 (5.55)	16.7 (0.66)
OMP 160	145.5 (5.73)	20.8 (0.82)
OMP 200	150.5 (5.93)	26.0 (1.02)
OMP 250	157.0 (6.18)	32.5 (1.28)
OMP 315	165.5 (6.52)	40.9 (1.61)
OMP 400	176.6 (6.95)	52.0 (2.05)

C: Drain connection
G¹/₄; 12 mm (0.47 in) deep
D: G¹/₂; 15 mm (0.59 in) deep
E: M8; 13 mm (0.51 in) deep
(4 pcs.)

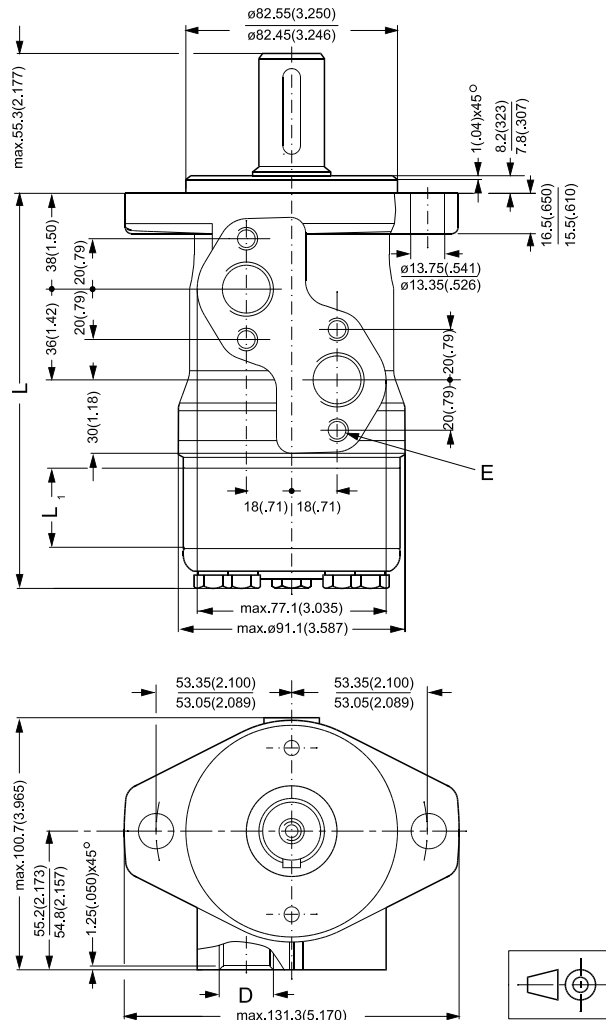

DIMENSIONS

Side port version with 2 hole oval mounting flange (A2-flange).
With drain connection.

Type	L mm (in)	L ₁ mm (in)
OMP 25	129.0 (5.08)	4.1 (0.16)
OMP 32	130.0 (5.12)	5.2 (0.20)
OMP 40	131.0 (5.16)	6.5 (0.26)
OMP 50	131.0 (5.16)	6.5 (0.26)
OMP 80	135.0 (5.31)	10.4 (0.41)
OMP 100	137.5 (5.41)	13.0 (0.51)
OMP 125	141.0 (5.55)	16.7 (0.66)
OMP 160	145.5 (5.73)	20.8 (0.82)
OMP 200	150.5 (5.93)	26.0 (1.02)
OMP 250	157.0 (6.18)	32.5 (1.28)
OMP 315	165.5 (6.52)	40.9 (1.61)
OMP 400	176.6 (6.95)	52.0 (2.05)

- C: Drain connection
G 1/4; 12 mm (0.47 in) deep
- D: G 1/2; 15 mm (0.59 in) deep
- E: M8; 13 mm (0.51 in) deep
(4 pcs.)

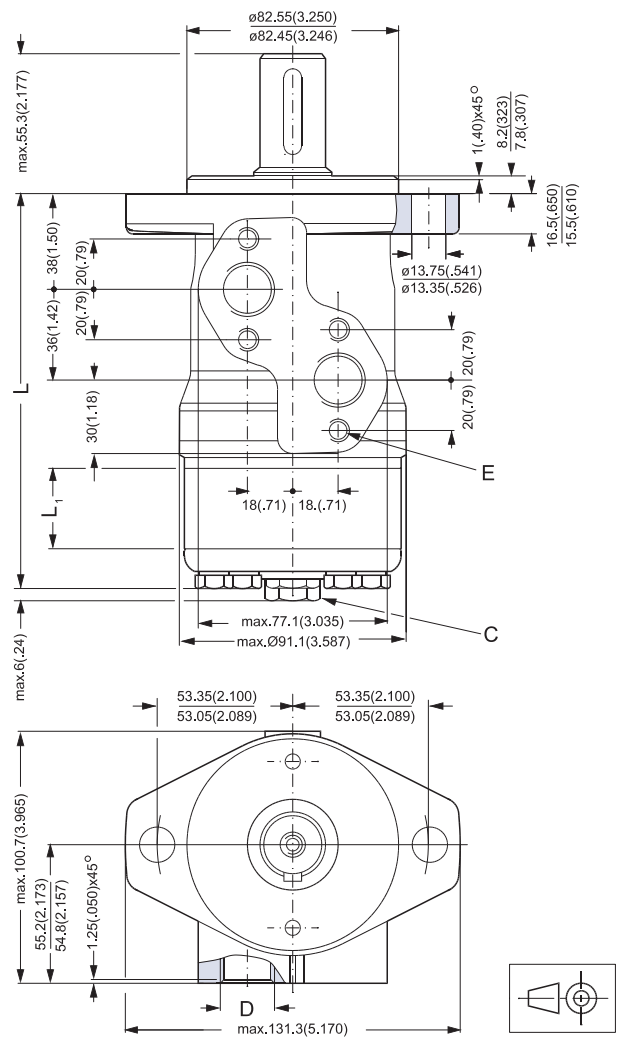

151-1850.10

DIMENSIONS

OMP C
Side port version with 2 hole oval mounting flange (A2-flange).

Type	L mm (in)	L ₁ mm (in)
OMP 50	131.0 (5.16)	6.5 (0.26)
OMP 80	135.0 (5.31)	10.4 (0.41)
OMP 100	137.5 (5.41)	13.0 (0.51)
OMP 125	141.0 (5.55)	16.7 (0.66)
OMP 160	145.5 (5.73)	20.8 (0.82)
OMP 200	150.5 (5.93)	26.0 (1.02)
OMP 250	157.0 (6.18)	32.5 (1.28)
OMP 315	165.5 (6.52)	40.9 (1.61)
OMP 400	176.6 (6.95)	52.0 (2.05)

C: Drain connection
G¹/₄; 12 mm (0.47 in) deep
D: G¹/₂; 15 mm (0.59 in) deep
E: M8; 13 mm (0.51 in) deep
(4 pcs.)

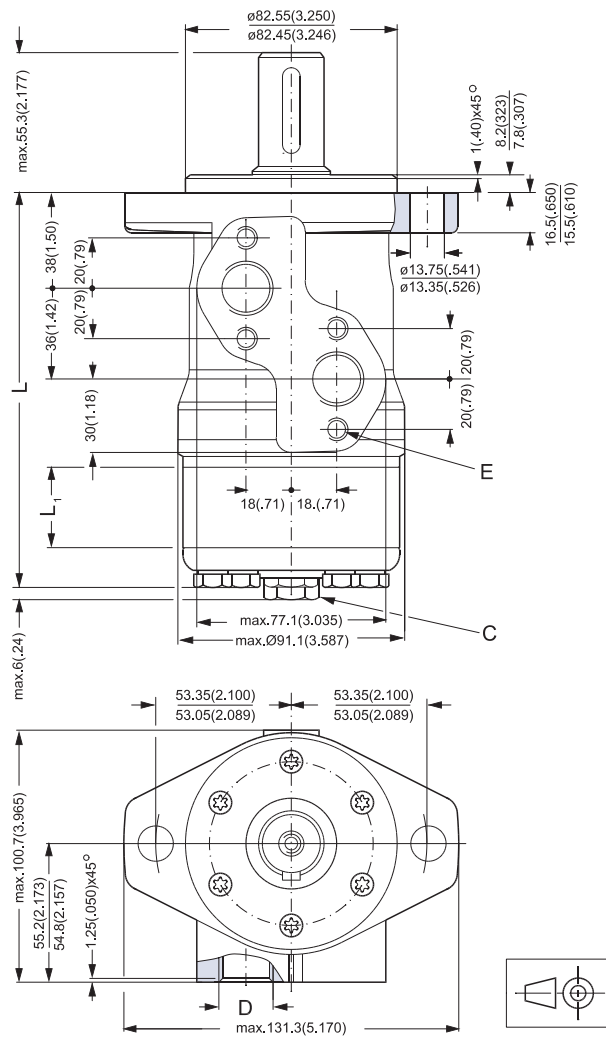

151-1841.10

DIMENSIONS

End port version with 2 hole oval mounting flange (A2-flange).

Type	L mm (in)	L ₁ mm (in)
OMP 50	145.1 (5.71)	6.5 (0.26)
OMP 80	149.0 (5.87)	10.4 (0.41)
OMP 100	151.7 (5.97)	13.0 (0.51)
OMP 125	155.2 (6.11)	16.3 (0.66)
OMP 160	159.4 (6.28)	20.8 (0.82)
OMP 200	164.6 (6.48)	26.0 (1.02)
OMP 250	171.1 (6.74)	32.5 (1.28)
OMP 315	179.5 (7.07)	40.9 (1.61)
OMP 400	190.6 (7.50)	52.0 (2.05)

C: Drain connection
G 1/4; 12 mm (0.47 in) deep
D: G 1/2; 15 mm (0.59 in) deep

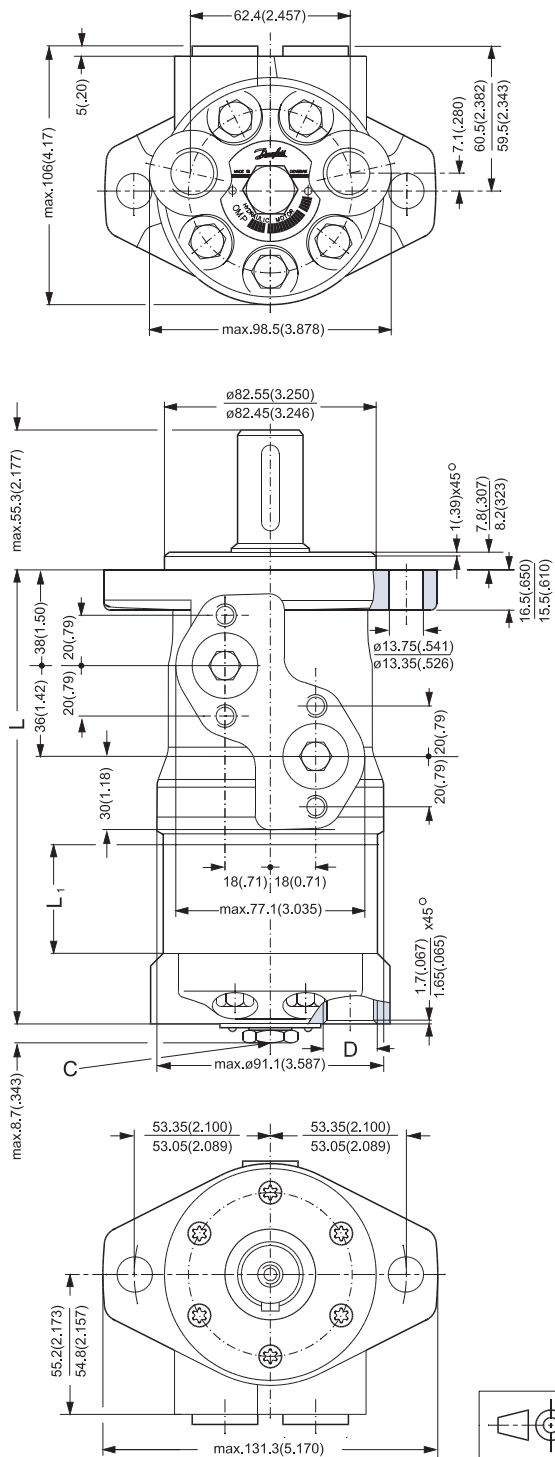

151-1748.10

DIMENSIONS

Side port version with 2 hole oval mounting flange (A2-flange).

Type	L mm (in)	L ₁ mm (in)
OMP 25	135.0 (5.31)	4.1 (0.16)
OMP 32	136.0 (5.35)	5.2 (0.20)
OMP 40	137.0 (5.39)	6.5 (0.26)
OMP 50	137.0 (5.39)	6.5 (0.26)
OMP 80	141.0 (5.55)	10.4 (0.41)
OMP 100	143.5 (5.65)	13.0 (0.51)
OMP 125	147.0 (5.79)	16.7 (0.66)
OMP 160	151.5 (5.96)	20.8 (0.82)
OMP 200	156.5 (6.16)	26.0 (1.02)
OMP 250	163.0 (6.42)	32.5 (1.28)
OMP 315	171.5 (6.75)	40.9 (1.61)
OMP 400	182.6 (7.19)	52.0 (2.05)

- C: Drain connection
7/16 - 20 UNF;
12 mm (0.47 in) deep
- D: 7/8 - 14 UNF;
16.7 mm (0.66 in) deep
or 1/2 - 14 NPTF
- E: M8; 13 mm (0.51 in) deep
(4-off)

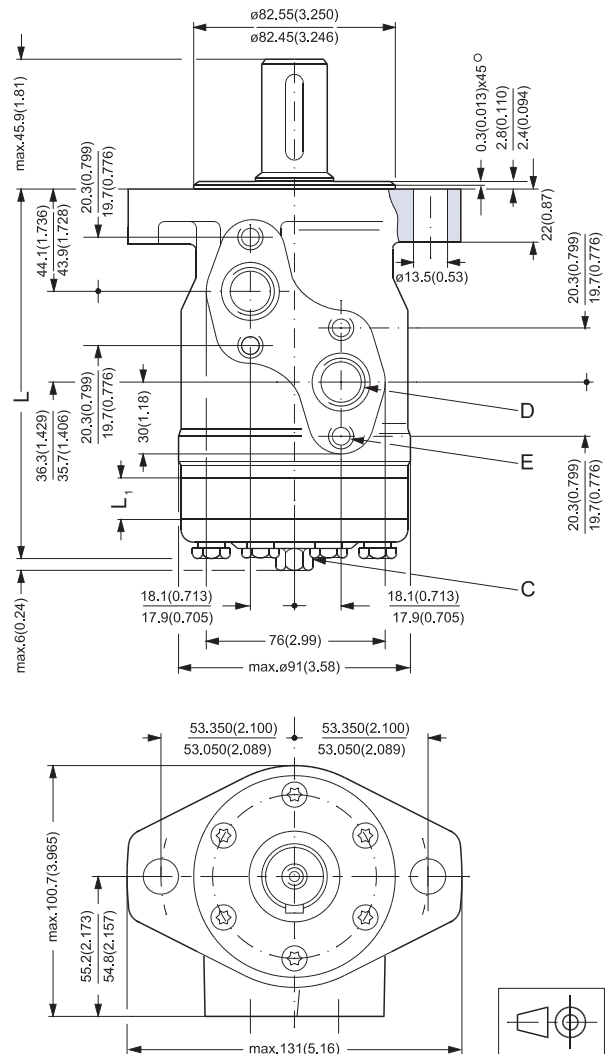

151-1217.10

DIMENSIONS

Side port version with 4 hole oval mounting flange (A4-flange).

Type	L mm (in)	L ₁ mm (in)
OMP 50	131.0 (5.16)	6.5 (0.26)
OMP 80	135.0 (5.31)	10.4 (0.41)
OMP 100	137.5 (5.41)	13.0 (0.51)
OMP 125	141.0 (5.55)	16.7 (0.66)
OMP 160	145.5 (5.73)	20.8 (0.82)
OMP 200	150.5 (5.93)	26.0 (1.02)
OMP 250	157.0 (6.18)	32.5 (1.28)
OMP 315	165.5 (6.52)	40.9 (1.61)
OMP 400	176.6 (6.95)	52.0 (2.05)

- C: Drain connection
G 1/4; 12 mm (0.47 in) deep
- D: G 1/2; 15 mm (0.59 in) deep
- E: M8; 13 mm (0.51 in) deep
(4 pcs.)

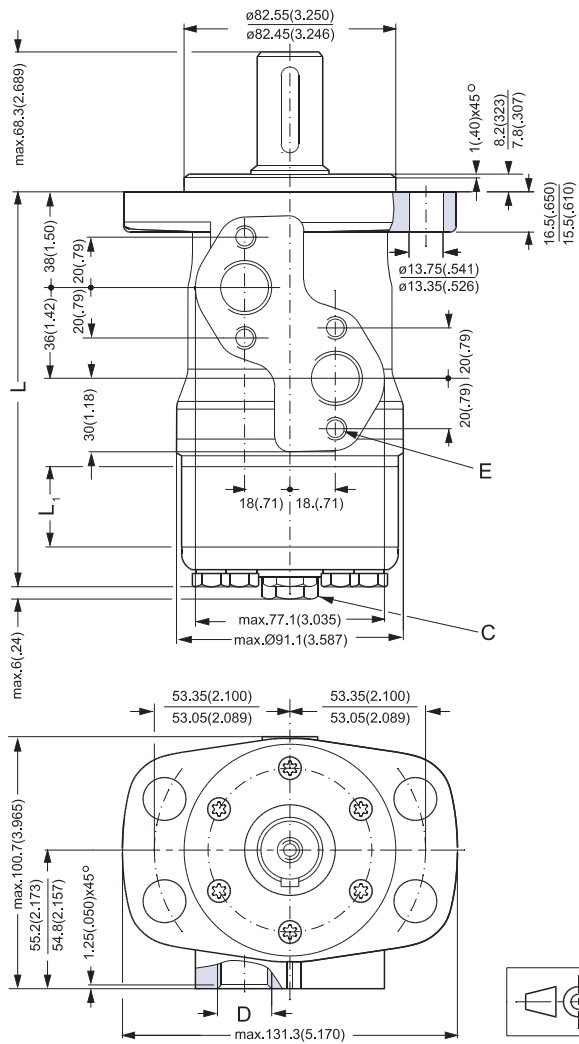

151-1747.10

DIMENSIONS

End port version with square mounting flange (C-flange).

Type	L mm (in)	L ₁ mm (in)
OMP 50	151.1 (5.94)	6.5 (0.26)
OMP 80	155 (6.10)	10.4 (0.41)
OMP 100	157.6 (6.20)	13.0 (0.51)
OMP 125	161.1 (6.34)	16.7 (0.66)
OMP 160	165.4 (6.51)	20.8 (0.82)
OMP 200	170.6 (6.72)	26.0 (1.02)
OMP 250	177.1 (6.97)	32.5 (1.28)
OMP 315	185.5 (7.30)	40.9 (1.61)
OMP 400	196.6 (7.74)	52.0 (2.05)

- C: Drain connection
G 1/4; 12 mm (0.47 in) deep
- D: G 1/2; 15 mm (0.59 in) deep
- E: M10; 15 mm (0.59 in) deep
(4 pcs.)

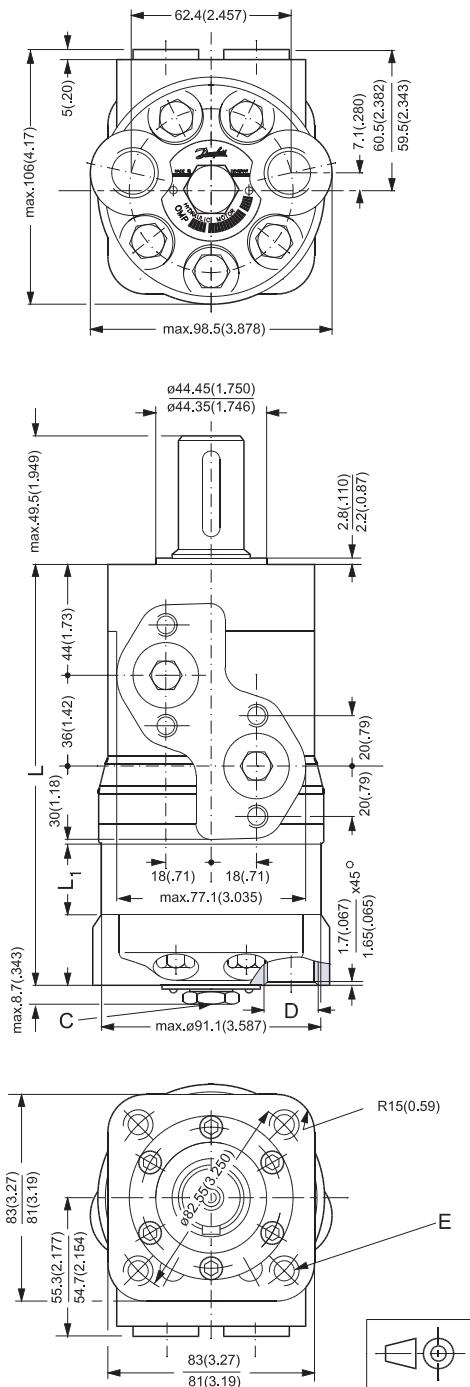

151-1749.10

DIMENSIONS

Side port version with square mounting flange (C-flange).

Type	L mm (in)	L ₁ mm (in)
OMP 50	131.0 (5.16)	6.5 (0.26)
OMP 80	135.0 (5.31)	10.4 (0.41)
OMP 100	137.5 (5.41)	13.0 (0.51)
OMP 125	141.0 (5.55)	16.7 (0.66)
OMP 160	145.5 (5.73)	20.8 (0.82)
OMP 200	150.5 (5.93)	26.0 (1.02)
OMP 250	157.0 (6.18)	32.5 (1.28)
OMP 315	165.5 (6.52)	40.9 (1.61)
OMP 400	176.6 (6.95)	52.0 (2.05)

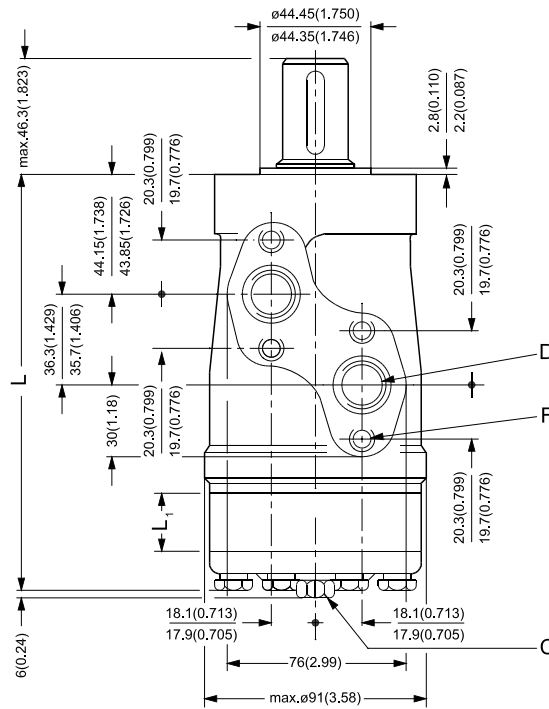

- C: Drain connection
7/16 - 20 UNF;
11.94 mm (0.47 in) deep
- D: 7/8 - 14 UNF;
16.76 mm (0.66 in) deep
or 1/2 - 14 NPTF
- E: 3/8 - 16 UNC;
14.97 mm (0.59 in) deep
(4-off)
- F: M8; 12.95 mm (0.51 in) deep
(4-off)

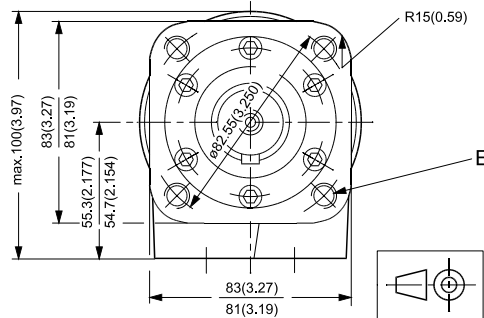

151-1214.10

DIMENSIONS

OMPW

OMPW N

Type	mm L ₂ (in)
OMPW with Ø25 mm shaft	115.0 (4.53)
OMPW N with tapered shaft	116.0 (4.57)

Type	L mm (in)	L ₁ mm (in)
OMP 50	70.8 (2.78)	6.5 (0.26)
OMP 80	74.7 (2.97)	10.4 (0.41)
OMP 100	77.3 (3.04)	13.0 (0.51)
OMP 125	80.6 (3.17)	16.7 (0.66)
OMP 160	85.1 (3.35)	20.8 (0.82)
OMP 200	90.3 (3.56)	26.0 (1.02)
OMP 250	96.8 (3.81)	32.5 (1.28)
OMP 315	105.2 (4.14)	40.9 (1.61)
OMP 400	116.3 (4.58)	52.0 (2.05)

- C: Drain connection
G 1/4; 12 mm (0.47 in) deep
- D: G 1/2; 15 mm (0.59 in) deep
- E: M10; 20 mm (0.79 in) deep
(4 pcs.)

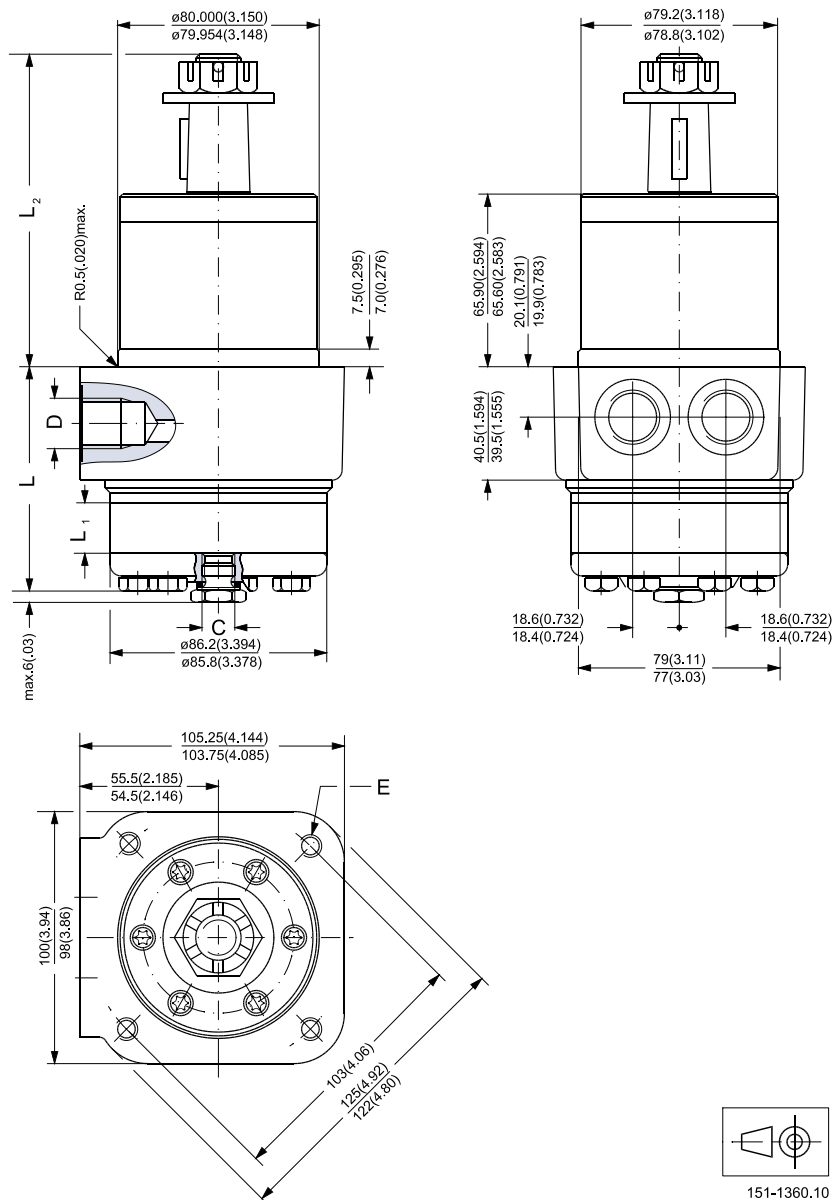

VERSIONS

Mounting flange	Shaft	Port size	European version	US version	Side port version	End port version	Flange port version	Standard shaft seal	High pressure shaft seal	Drain connection	Check valve	Specials	Main type designation
2 hole oval flange (A2-flange)	Cyl. 25 mm	G 1/2	X		X				X	No	No		OMR
		G 1/2	X		X				X	Yes	Yes		OMR
		G 1/2	X		X			X		Yes	Yes	A	OMR C
		G 1/2	X			X		X		Yes	Yes		OMR
	Cyl 1 in	G 1/2	X		X				X	No	No		OMR
		G 1/2	X		X				X	Yes	Yes		OMR
		7/8 - 14 UNF		X	X			X		Yes	Yes		OMR
	Splined 1 in	G 1/2	X		X				X	No	No		OMR
		G 1/2	X		X				X	Yes	Yes		OMR
		7/8 - 14 UNF		X	X			X		Yes	Yes		OMR
Cyl. 32 mm	G 1/2	X		X			X		Yes	Yes		OMR	
Tap. 28.5 mm	G 1/2	X		X			X		Yes	Yes		OMR	
4 hole oval flange (A4-flange)	Cyl. 25 mm	G 1/2	X		X			X		Yes	Yes		OMR
	Cyl. 32 mm	G 1/2	X		X			X		Yes	Yes		OMR
	Cyl. 1 1/4 in	7/8 - 14 UNF		X	X			X		Yes	Yes		OMR
Square flange (C-flange)	Cyl. 25 mm	G 1/2	X			X		X		Yes	Yes		OMR
	Cyl. 1 in	7/8 - 14 UNF		X	X			X		Yes	Yes		OMR
Wheel	Tap. 35 mm	G 1/2	X				X	X		Yes	Yes	B	OMRW N
	Tap. 1 1/4 in	7/8 - 14 UNF		X			X	X		Yes	Yes	B	OMRW N

Function diagram – see page : →

Specials:

A : Corrosion resistant parts
B : With needle bearings

Features available (options) :

Free running gerotor
Low leakage (low speed valve)
Speed sensor
Viton shaft seal
Reverse rotation
Drain
Corrosion protected
Painted
With needle bearings
With brake

CODE NUMBERS

CODE NUMBERS	DISPLACEMENT [cm ³]									Technical data – Page	Dimensions – Page
	50	80	100	125	160	200	250	315	375		
151-	0410	0411	0412	0413	0414	0415	0416	0417	0418	38	55
151-	0710	0711	0712	0713	0714	0715	0716	0717	0718	38	56
151-	1231	1232	1233	1238	1234	1235	1236	1237	1243	38	57
151-	6190	6191	6192	6193	6194	6195	6196	6197	6198	38	58
151-	0400	0401	0402	0403	0404	0405	0406	0407	0408	38	55
151-	0700	0701	0702	0703	0704	0705	0706	0707	0708	38	56
151-	7240	7241	7242	7243	7244	7245	7246	7247	7248	38	59
151-	0420	0421	0422	0423	0424	0425	0426	0427	0428	39	55
151-	0720	0721	0722	0723	0724	0725	0726	0727	0728	39	56
151-	7250	7251	7252	7253	7254	7255	7256	7257	7258	39	59
151-	0248	0242	0243	0208	0244	0245	0247	0246	6294	40	57
151-	0265	0266	0267	6295	0268	0269	0271	0270	6296	39	57
151-	6010	6011	6012	6013	6014	6015	6016	6017	6018	38	60
151-	6000	6001	6002	6003	6004	6005	6006	6007	6008	40	60
151-	6110	6111	6112	6113	6114	6115	6116	6117	6118	40	61
151-	6210	6211	6212	6213	6214	6215	6216	6217	6218	38	62
151-	7260	7261	7262	7263	7264	7265	7266	7267	7269	38	63
151-	6300	6301	6302	6303	6304	6305	6306	6307	6308	40	64
151-	6430	6431	6432	6433	6434	6435	6436	6437	6438	40	650
	45	45	46	46	47	47	48	48	49		

Ordering

Add the four digit prefix "151-" to the four digit numbers from the chart for complete code number.

Example:

151-6004 for an OMR 160 with A4 flange, cyl. 32 mm shaft, port size G 1/2 and side port version.

Note: Orders will not be accepted without the four digit prefix.

TECHNICAL DATA FOR OMR WITH 25 MM AND 1 IN CYLINDRICAL SHAFT

Type		OMR	OMR	OMR	OMR	OMR	OMR	OMR	OMR	OMR	
Motor size		50	80	100	125	160	200	250	315	375	
Geometric displacement	cm ³ (in ³)	51.6 (3.16)	80.3 (4.91)	99.8 (6.11)	125.7 (7.69)	159.6 (9.77)	199.8 (12.23)	249.3 (15.26)	315.7 (19.32)	372.6 (22.80)	
Max. speed	min ⁻¹ (rpm)	cont.	775	750	600	475	375	300	240	190	160
		int. ¹⁾	970	940	750	600	470	375	300	240	200
Max. torque	Nm (lbf-in)	cont.	100 (890)	195 (1730)	240 (2120)	300 (2660)	300 (2660)	300 (2660)	300 (2660)	300 (2660)	300 (2660)
		int. ¹⁾	130 (1150)	220 (1957)	280 (2480)	340 (3010)	390 (3450)	390 (3450)	380 (3360)	420 (3720)	430 (3810)
		peak ²⁾	170 (1510)	270 (2390)	320 (2830)	370 (3280)	460 (4070)	560 (4960)	600 (5310)	610 (5400)	600 (5310)
Max. output	kW (hp)	cont.	7.0 (9.4)	12.5 (16.8)	13.0 (17.4)	12.5 (16.8)	10.0 (13.4)	8.0 (10.7)	6.0 (8.1)	5.0 (6.7)	4.0 (5.4)
		int. ¹⁾	8.5 (11.4)	15.0 (20.1)	15.0 (20.1)	14.5 (19.4)	12.5 (16.8)	10.0 (13.4)	8.0 (10.7)	6.5 (8.7)	6.0 (8.1)
Max. pressure drop	bar (psi)	cont.	140 (2030)	175 (2540)	175 (2540)	175 (2540)	130 (1890)	110 (1600)	80 (1160)	70 (1020)	55 (800)
		int. ¹⁾	175 (2540)	200 (2900)	200 (2900)	200 (2900)	175 (2540)	140 (2030)	110 (1600)	100 (1450)	85 (1230)
		peak ²⁾	225 (3260)	225 (3260)	225 (3260)	225 (3260)	225 (3260)	225 (3260)	200 (2900)	150 (2180)	130 (1890)
Max. oil flow	l/min (US gal/min)	cont.	40 (10.6)	60 (15.9)	60 (15.9)	60 (15.9)	60 (15.9)	60 (15.9)	60 (15.9)	60 (15.9)	60 (15.9)
		int. ¹⁾	50 (13.2)	75 (19.8)	75 (19.8)	75 (19.8)	75 (19.8)	75 (19.8)	75 (19.8)	75 (19.8)	75 (19.8)
Max. starting pressure with unloaded shaft	bar (psi)	10 (145)	10 (145)	10 (145)	9 (130)	7 (100)	5 (75)	5 (75)	5 (75)	5 (75)	
Min. starting torque	at max. press. drop cont.	80 (710)	150 (1330)	200 (1770)	250 (2210)	240 (2120)	260 (2300)	240 (2120)	260 (2300)	240 (2120)	
	at max. press. drop int. ¹⁾	100 (890)	170 (1500)	230 (2040)	280 (2480)	320 (2830)	330 (2920)	310 (2740)	350 (3100)	380 (3360)	
Min. speed ³⁾	min ⁻¹ (rpm)	10	10	10	9	7	5	5	5	5	

¹⁾ Intermittent operation: the permissible values may occur for max. 10% of every minute.

²⁾ Peak load: the permissible values may occur for max. 1% of every minute.

³⁾ Operation at lower speeds may be slightly less smooth.

TECHNICAL DATA FOR OMR WITH 1 IN SPLINED AND 28.5 MM TAPERED SHAFT

Type		OMR	OMR	OMR	OMR	OMR	OMR	OMR	OMR	OMR	
Motor size		50	80	100	125	160	200	250	315	375	
Geometric displacement	cm ³ (in ³)	51.6 (3.16)	80.3 (4.91)	99.8 (6.11)	125.7 (7.69)	159.6 (9.77)	199.8 (12.23)	249.3 (15.26)	315.7 (19.32)	372.6 (22.80)	
Max. speed	min ⁻¹ (rpm)	cont.	775	750	600	475	375	300	240	190	160
		int. ¹⁾	970	940	750	600	470	375	300	240	200
Max. torque	Nm (lbf-in)	cont.	100 (890)	195 (1730)	240 (2120)	300 (2660)	360 (3190)	360 (3190)	360 (3190)	360 (3190)	360 (3190)
		int. ¹⁾	130 (1150)	220 (1950)	280 (2480)	340 (3010)	430 (3810)	440 (3890)	470 (4160)	470 (4160)	460 (4070)
		peak ²⁾	170 (1500)	270 (2390)	320 (2830)	370 (3280)	460 (4070)	560 (4960)	600 (5310)	610 (5400)	600 (5310)
Max. output	kW (hp)	cont.	7.0 (9.4)	12.5 (16.8)	13.0 (17.4)	12.5 (16.8)	12.5 (16.8)	10.0 (13.4)	7.0 (9.4)	5.0 (6.7)	5.0 (6.7)
		int. ¹⁾	8.5 (11.4)	15.0 (20.1)	15.0 (20.1)	14.5 (19.4)	14.0 (18.8)	13.0 (17.4)	9.5 (12.7)	8.0 (10.7)	7.0 (9.4)
Max. pressure drop	bar (psi)	cont.	140 (2030)	175 (2540)	175 (2540)	175 (2540)	165 (2390)	130 (1890)	100 (1450)	85 (1230)	70 (1020)
		int. ¹⁾	175 (2540)	200 (2900)	200 (2900)	200 (2900)	200 (2900)	175 (2540)	140 (2030)	115 (1670)	90 (1310)
		peak ²⁾	225 (3260)	225 (3260)	225 (3260)	225 (3260)	225 (3260)	225 (3260)	200 (2900)	150 (2180)	130 (1890)
Max. oil flow	l/min (US gal/min)	cont.	40 (10.6)	60 (15.9)	60 (15.9)	60 (15.9)	60 (15.9)	60 (15.9)	60 (15.9)	60 (15.9)	60 (15.9)
		int. ¹⁾	50 (13.2)	75 (19.8)	75 (19.8)	75 (19.8)	75 (19.8)	75 (19.8)	75 (19.8)	75 (19.8)	75 (19.8)
Max. starting pressure with unloaded shaft	bar (psi)	10 (145)	10 (145)	10 (145)	9 (131)	7 (102)	5 (73)	7 (102)	5 (73)	5 (73)	
Min. starting torque	at max. press. drop cont.	80 (710)	150 (1330)	200 (1770)	250 (2210)	300 (2660)	300 (2660)	290 (2570)	315 (2790)	300 (2660)	
	at max. press. drop int. ¹⁾	100 (890)	170 (1500)	230 (2040)	280 (2480)	350 (3100)	400 (3540)	400 (3540)	400 (3540)	380 (3360)	
Min. speed ³⁾	min ⁻¹ (rpm)	10	10	10	9	7	5	5	5	5	

¹⁾ Intermittent operation: the permissible values may occur for max. 10% of every minute.

²⁾ Peak load: the permissible values may occur for max. 1% of every minute.

³⁾ Operation at lower speeds may be slightly less smooth.

TECHNICAL DATA FOR OMR/OMRW WITH 32 MM, 1 1/4 IN CYLINDRICAL SHAFT AND 35 MM, 1 1/4 IN TAPERED SHAFT

Type		OMR	OMR	OMR	OMR	OMR	OMR	OMR	OMR	OMR	
Motor size		50	80	100	125	160	200	250	315	375	
Geometric displacement	cm ³ (in ³)	51.6 (3.16)	80.3 (4.91)	99.8 (6.11)	125.7 (7.69)	159.6 (9.77)	199.8 (12.23)	249.3 (15.26)	315.7 (19.32)	372.6 (22.80)	
Max. Speed	min ⁻¹ (rpm)	cont.	775	750	600	475	375	300	240	190	160
		int. ¹⁾	970	940	750	600	470	375	300	240	200
Max. Torque	Nm (lbf-in)	cont.	100 (890)	195 (1730)	240 (2120)	300 (2660)	380 (3360)	450 (3980)	540 (4780)	550 (4870)	580 (5130)
		int. ¹⁾	130 (1150)	220 (1950)	280 (2480)	340 (3010)	430 (3810)	500 (4430)	610 (5400)	690 (6110)	690 (6110)
		peak ²⁾	170 (1510)	270 (2390)	320 (2830)	370 (3280)	460 (4070)	560 (4960)	710 (6280)	840 (7440)	830 (7350)
Max. output	kW (hp)	cont.	7.0 (9.4)	12.5 (16.8)	13.0 (17.4)	12.5 (16.8)	12.5 (16.8)	11.0 (14.8)	10.0 (13.4)	9.0 (12.1)	7.5 (10.1)
		int. ¹⁾	8.5 (11.4)	15.0 (20.1)	15.0 (20.1)	14.5 (19.4)	14.0 (18.8)	13.0 (17.4)	12.0 (16.1)	10.0 (13.4)	9.0 (12.1)
Max. pressure drop	bar (psi)	cont.	140 (2030)	175 (2540)	175 (2540)	175 (2540)	175 (2540)	175 (2540)	175 (2540)	135 (1960)	115 (1670)
		int. ¹⁾	175 (2540)	200 (2900)	200 (2900)	200 (2900)	200 (2900)	200 (2900)	200 (2900)	175 (2540)	150 (2180)
		peak ²⁾	225 (3260)	225 (3260)	225 (3260)	225 (3260)	225 (3260)	225 (3260)	225 (3260)	225 (3260)	210 (3050)
Max. oil flow	l/min (USgal/min)	cont.	40 (10.6)	60 (15.9)	60 (15.9)	60 (15.9)	60 (15.9)	60 (15.9)	60 (15.9)	60 (15.9)	60 (15.9)
		int. ¹⁾	50 (13.2)	75 (19.8)	75 (19.8)	75 (19.8)	75 (19.8)	75 (19.8)	75 (19.8)	75 (19.8)	75 (19.8)
Max. starting pressure with unloaded shaft	bar (psi)	10 (145)	10 (145)	10 (145)	9 (130)	7 (100)	5 (75)	5 (75)	5 (75)	5 (75)	
Min. starting torque	at max. press. drop cont.	80 (710)	150 (1330)	200 (1770)	250 (2210)	320 (2830)	410 (3630)	500 (4430)	500 (4430)	470 (4170)	
	at max. press. drop int. ¹⁾	100 (890)	170 (1500)	230 (2040)	280 (2480)	370 (3280)	460 (4070)	550 (4870)	660 (5840)	570 (5050)	
Min. speed ³⁾	min ⁻¹ (rpm)	10	10	10	9	7	5	5	5	5	

Type		Max. inlet pressure	Max. return pressure with drain line
OMR 50 - 375	bar (psi) cont.	175 (2540)	175 (2540)
	bar (psi) int. ¹⁾	200 (2900)	200 (2900)
	bar (psi) peak ²⁾	225 (3260)	225 (3260)

¹⁾ Intermittent operation: the permissible values may occur for max. 10% of every minute.

²⁾ Peak load: the permissible values may occur for max. 1% of every minute.

³⁾ Operation at lower speeds may be slightly less smooth.

OMR WITH HIGH PRESSURE SHAFT SEAL (HPS)

OMR with HPS, without check valves and without drain connection:

The shaft seal pressure equals the average of input pressure and return pressure

$$P_{\text{seal}} = \frac{P_{\text{in}} + P_{\text{return}}}{2}$$

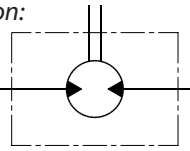

151-1743.10

OMR with HPS, check valves and with drain connection:

The shaft seal pressure equals the pressure in the drain line.

OMR with HPS, check valves and without drain connection:

The pressure on the shaft seal never exceeds the pressure in the return line.

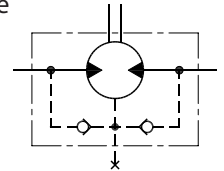

151-320.10

Max. permissible shaft seal pressure

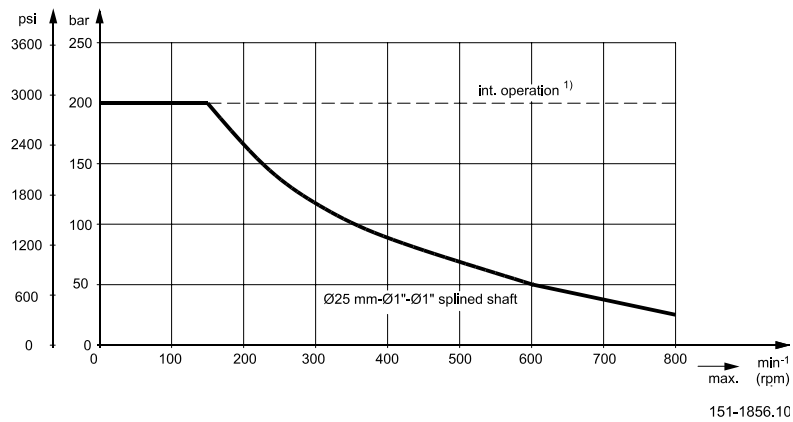

151-1856.10

OMR WITH STANDARD SHAFT SEAL

OMR with standard shaft seal, check valves and without use of drain connection:

The pressure on the shaft seal never exceeds the pressure in the return line

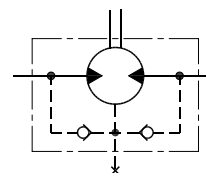

151-320.10

OMR with standard shaft seal, check valves and with drain connection:

The shaft seal pressure equals the pressure on the drain line.

Max. return pressure without drain line or max. pressure in the drain line

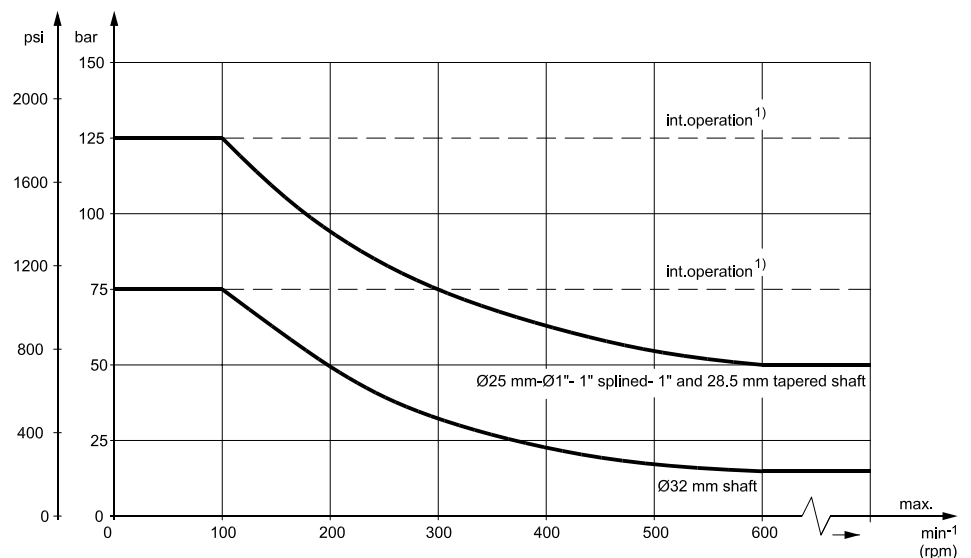

¹⁾ Intermittent operation: the permissible values may occur for max. 10% of every minute.

151-1563.10

PRESSURE DROP IN MOTOR

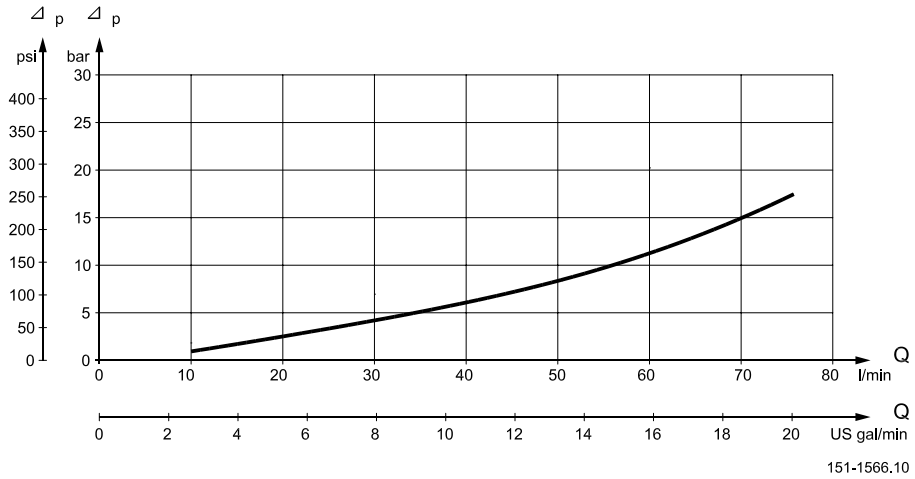

151-1566.10

The curve applies to an unloaded motor shaft and an oil viscosity of 35 mm²/s (165 SUS)

OIL FLOW IN DRAIN LINE

The table shows the max. oil flow in the drain line at a return pressure less than 5-10 bar (75-150 psi).

Pressure drop bar (psi)	Viscosity mm ² /s (SUS)	Oil flow in drain line l/min (US gal/min)
100 (1450)	20 (100)	2.5 (0.66)
	35 (165)	1.8 (0.78)
140 (2030)	20 (100)	3.5 (0.93)
	35 (165)	2.8 (0.74)

DIRECTION OF SHAFT ROTATION

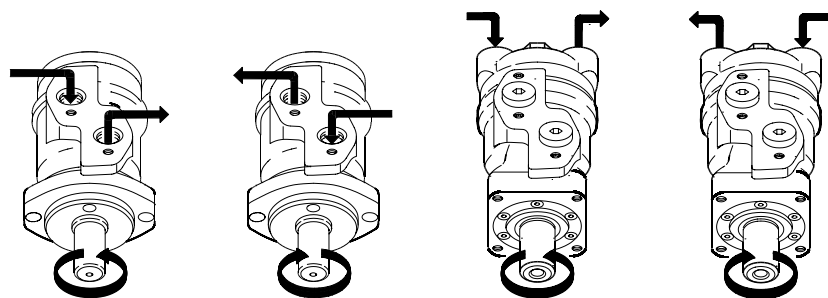

151-1836.10

**PERMISSIBLE SHAFT
LOAD FOR OMR**

The permissible radial shaft load (P_R) depends on

- speed (n)
- distance (l) from the point of load to the mounting flange
- mounting flange version
- shaft version

Mounting flange	4-hole oval flange** 2-hole oval flange (European version)	4-hole oval flange 2-hole oval flange	Square flange** 2-hole oval flange (US version)
Shaft version	25 mm cylindrical shaft 1 in cylindrical shaft 1 in splined shaft 28.5 mm tapered shaft	32 mm cylindrical shaft 1 1/4 in cylindrical shaft	25 mm cylindrical shaft 1 in cylindrical shaft
Permissible shaft load (P_R) l in mm	$\frac{800}{n} \times \frac{250000}{95+l} \text{ N}^*$	$\frac{800}{n} \times \frac{187500}{95+l} \text{ N}^*$	$\frac{800}{n} \times \frac{250000}{101+l} \text{ N}^*$
Permissible shaft load (P_R) l in inch	$\frac{800}{n} \times \frac{2215}{3.74+l} \text{ lbf}^*$	$\frac{800}{n} \times \frac{1660}{3.74+l} \text{ lbf}^*$	$\frac{800}{n} \times \frac{2215}{3.98+l} \text{ lbf}^*$

* $n \geq 200 \text{ min}^{-1} \text{ (rpm)}$; $l \leq 55 \text{ mm (2.2 in)}$
 $n < 200 \text{ min}^{-1} \text{ (rpm)}$; $\Rightarrow P_{R\text{max}} = 8000 \text{ N (1800 lbf)}$
 ** For both European and US version

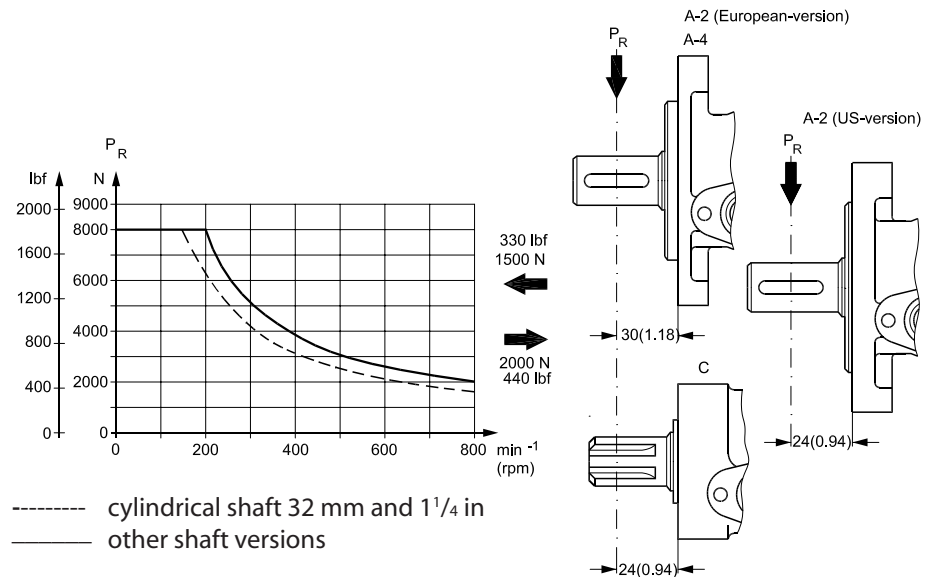

151-1203 10

The curve shows the relation between P_R and n

- when $l = 30 \text{ mm (1.18 in)}$ for motors with oval mounting flange
- when $l = 24 \text{ mm (0.94 in)}$ for motors with square mounting flange

For applications with special performance requirements we recommend OMR with the output shaft running in needle bearings.

**PERMISSIBLE SHAFT
LOAD FOR OMRW N
WITH NEEDLE BEARINGS**

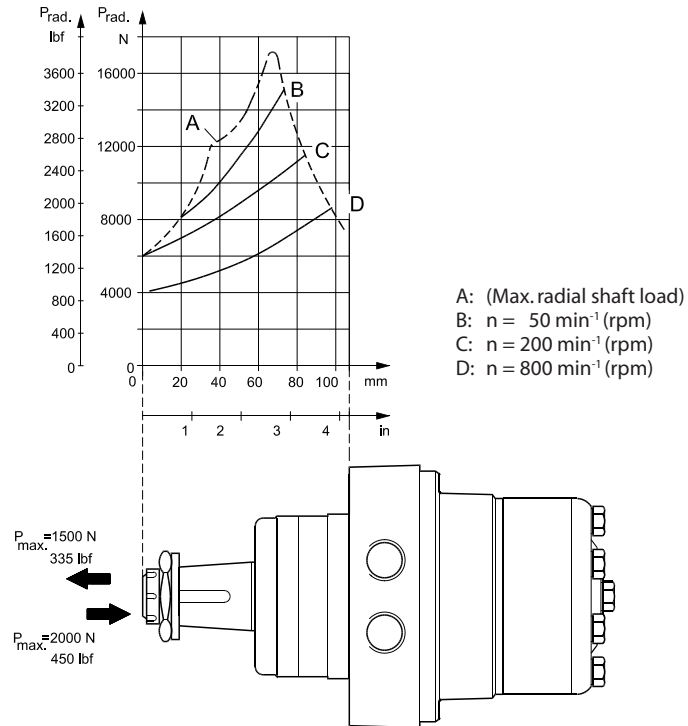

151-1388.10

The output shaft on OMRW N runs in needle bearings. These bearings and the recessed mounting flange allow a higher permissible radial load in comparison to OMR motors with slide bearings.

The permissible radial load on the shaft is shown for different speeds as a function of the distance from the mounting flange to the point of load application.

Curve A shows max. radial shaft load. Any shaft load exceeding the values quoted in the curve will involve a risk of breakage.

The other curves apply to a B10 bearing life of 2000 hours at the number of revolutions indicated by the curve letter. Mineral based hydraulic oil with a sufficient content of anti-wear additives must be used.

Bearing life calculations can be made using the explanation and formula provided in the chapter »Bearing dimensioning« in the technical information "General" DHMH.PK.100.G2.02 520L0232.

FUNCTION DIAGRAMS

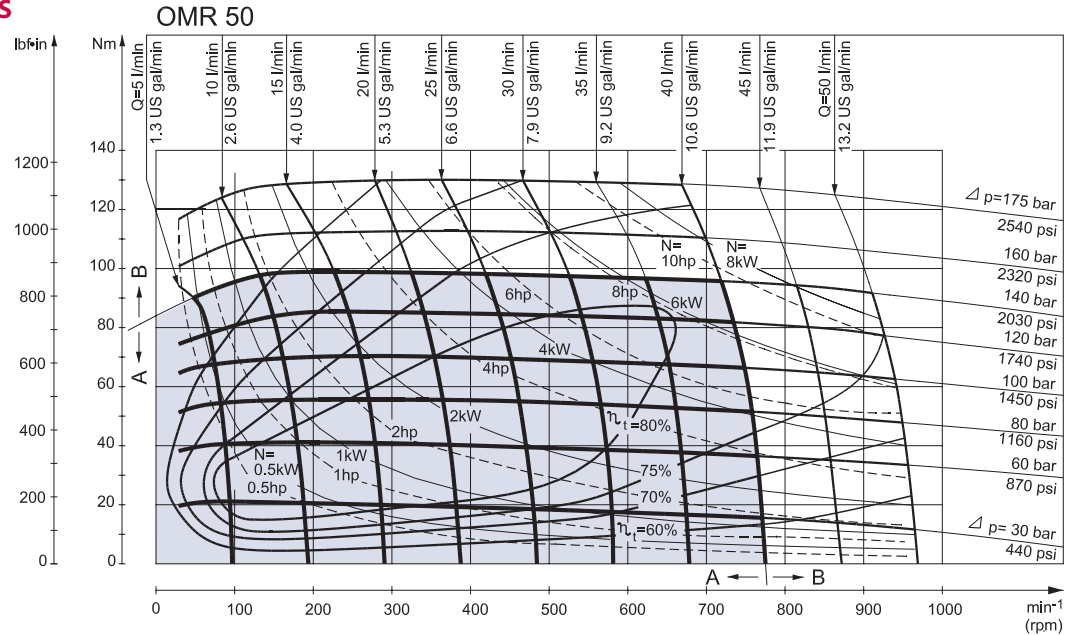

151-1172.10

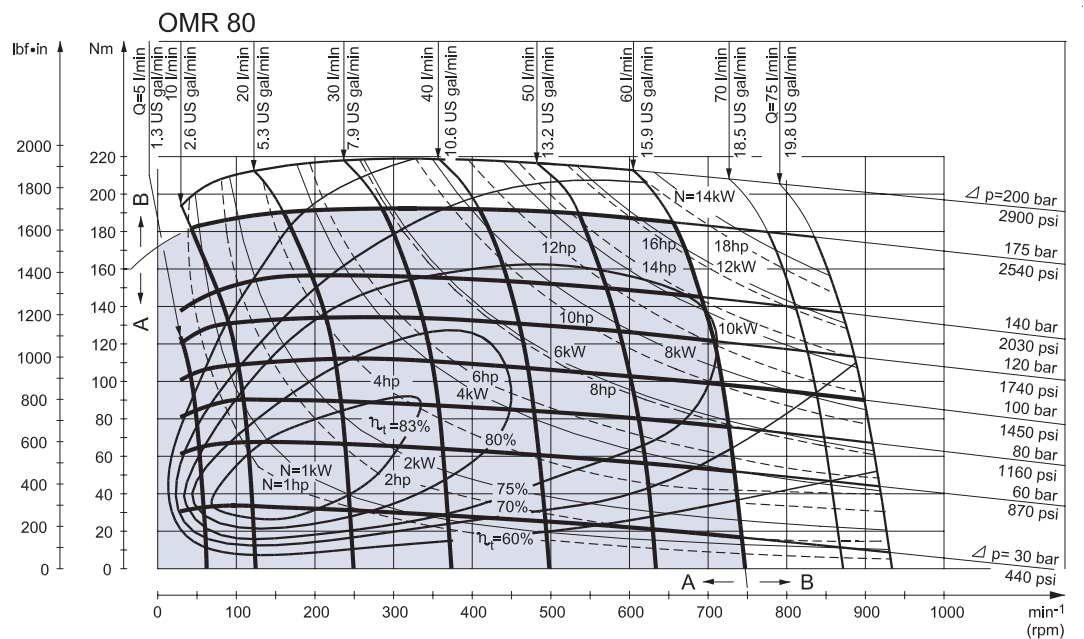

151-299.10

Explanation of function diagram use, basis and conditions can be found on page 7.

- A: Continuous range
- B: Intermittent range (max. 10% operation every minute)

Max. permissible continuous/intermittent pressure drop for the actual shaft version can be found on page 38-40.

Note: Intermittent pressure drop and oil flow must not occur simultaneously.

FUNCTION DIAGRAMS

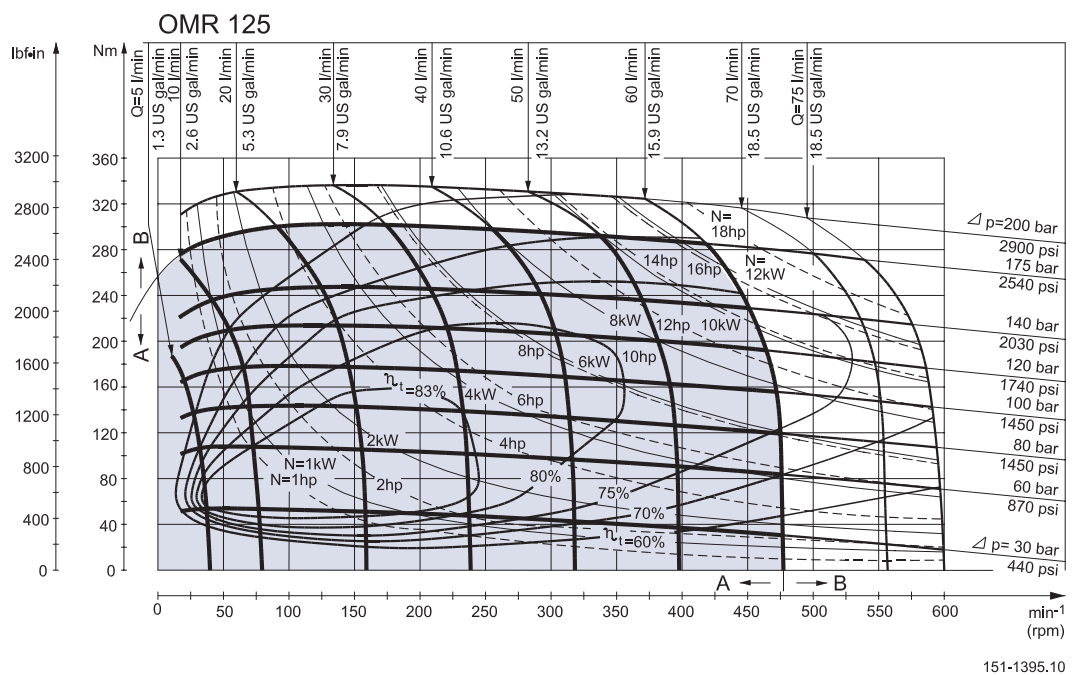
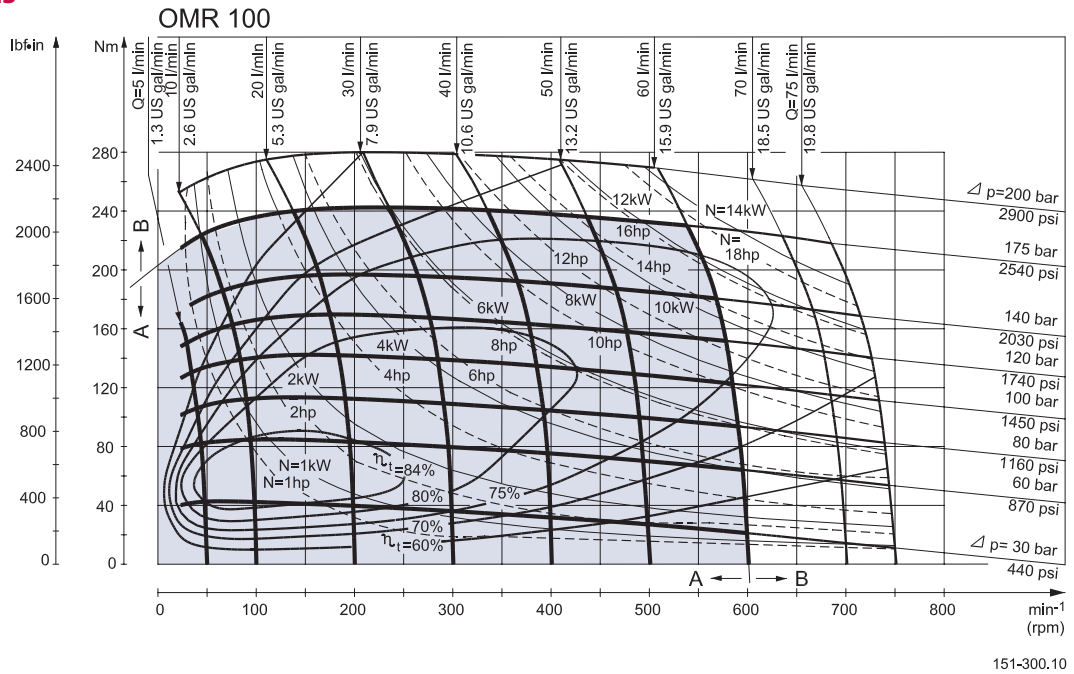

Explanation of function diagram use, basis and conditions can be found on page 7.

- A: Continuous range
- B: Intermittent range (max. 10% operation every minute)

Max. permissible continuous/intermittent pressure drop for the actual shaft version can be found on page 38-40.

Note: Intermittent pressure drop and oil flow must not occur simultaneously.

FUNCTION DIAGRAMS

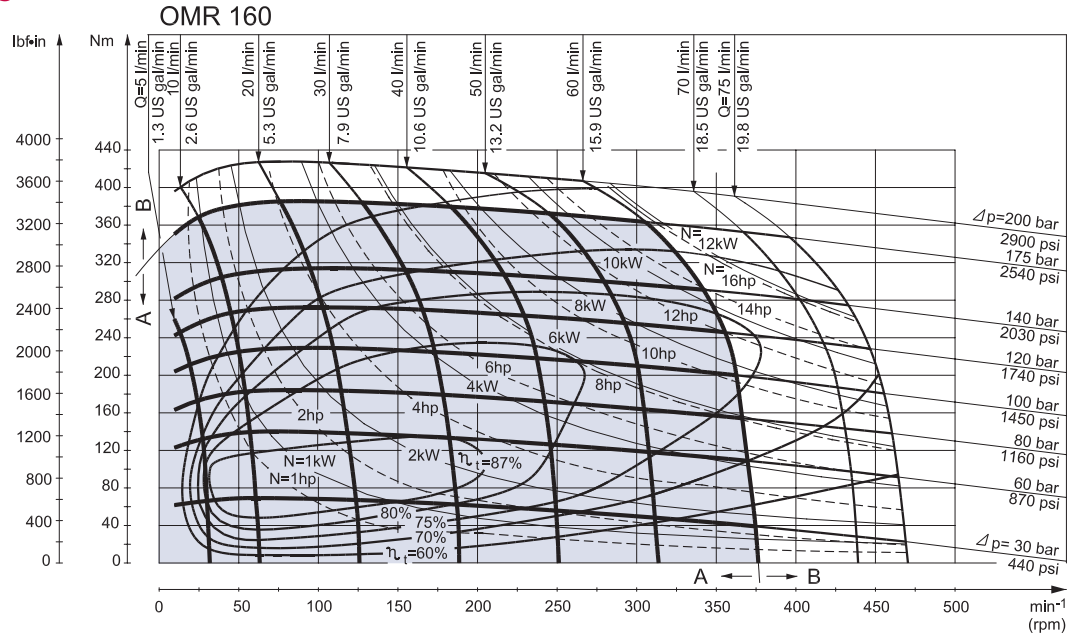

151-1044.10

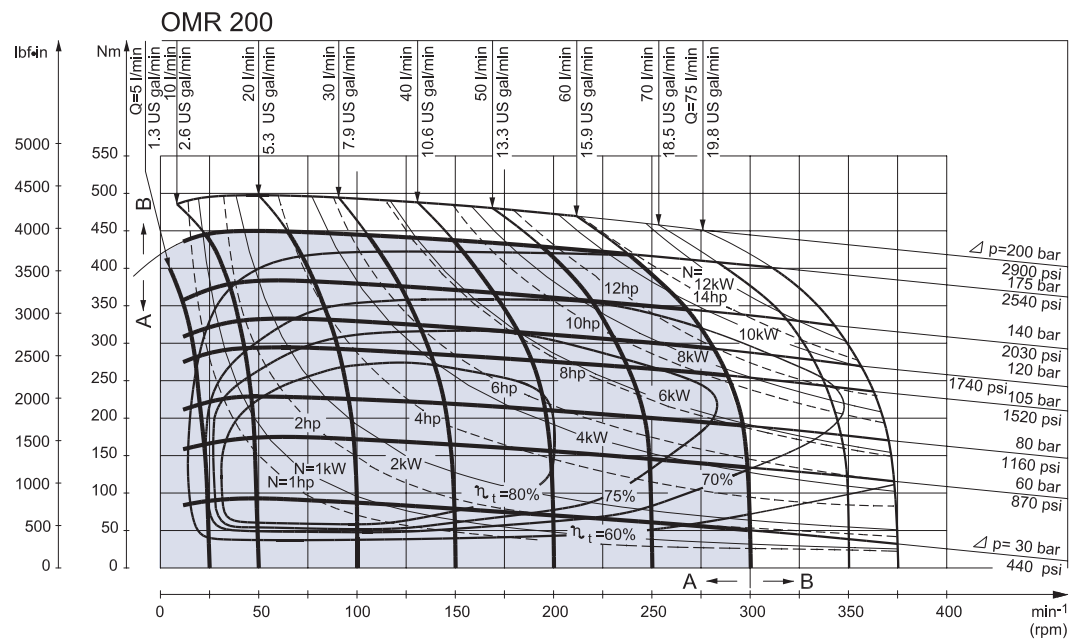

151-1396.10

Explanation of function diagram use, basis and conditions can be found on page 7.

- A: Continuous range
- B: Intermittent range (max. 10% operation every minute)

Max. permissible continuous/intermittent pressure drop for the actual shaft version can be found on page 38-40.

Note: Intermittent pressure drop and oil flow must not occur simultaneously.

FUNCTION DIAGRAMS

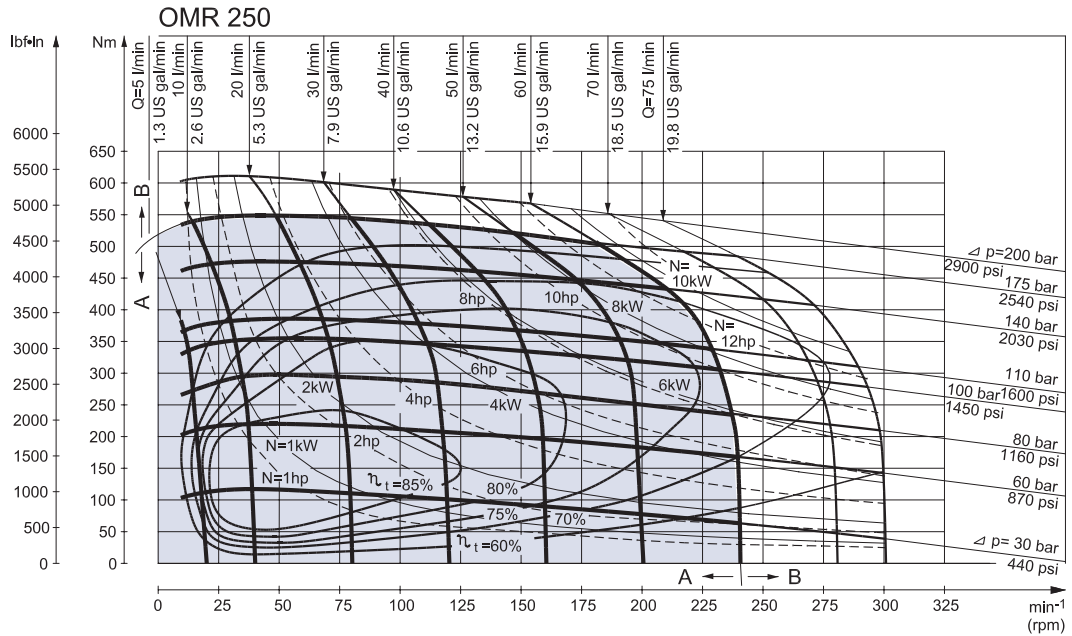

151-1119.10

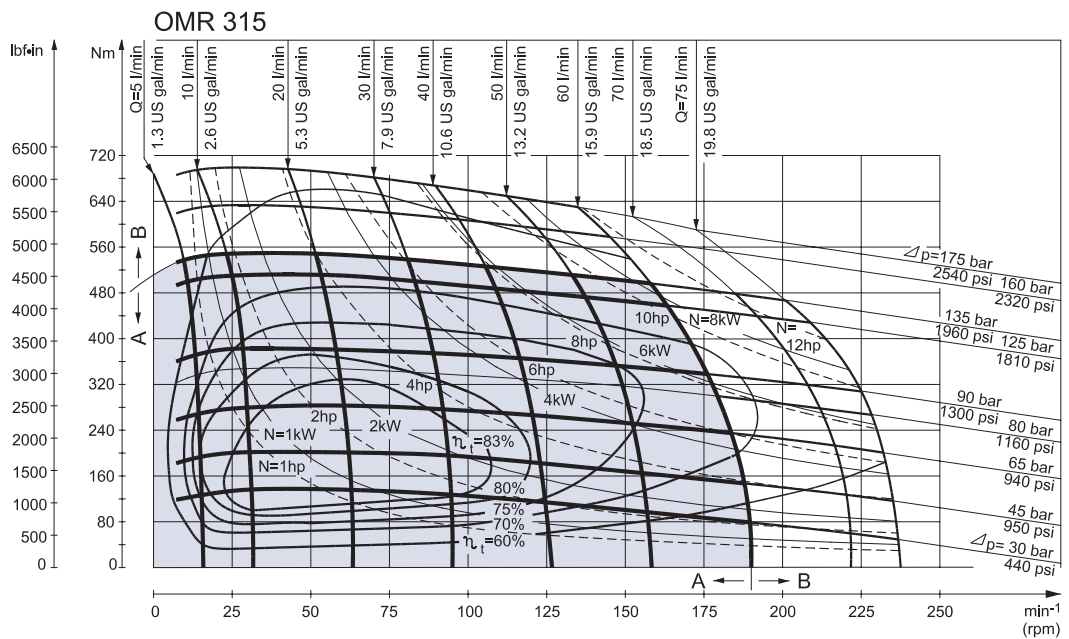

151-809.10

Explanation of function diagram use, basis and conditions can be found on page 7.

- A: Continuous range
- B: Intermittent range (max. 10% operation every minute)

Max. permissible continuous/intermittent pressure drop for the actual shaft version can be found on page 38-40.

Note: Intermittent pressure drop and oil flow must not occur simultaneously.

FUNCTION DIAGRAMS

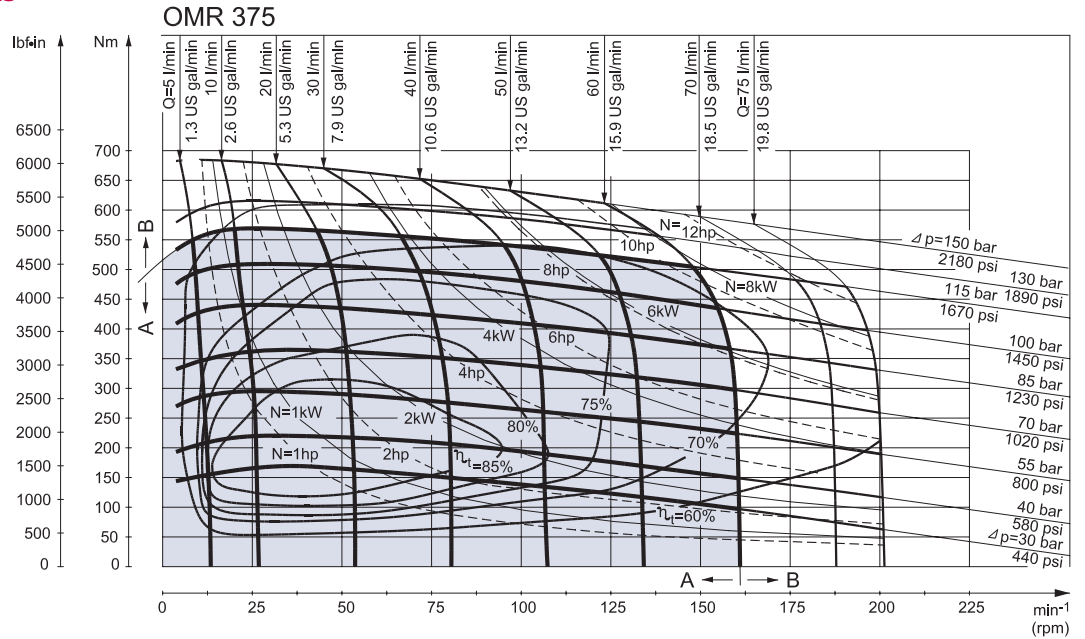

151-1385.10

Explanation of function diagram use, basis and conditions can be found on page 7.

- A: Continuous range
- B: Intermittent range (max. 10% operation every minute)

Max. permissible continuous/intermittent pressure drop for the actual shaft version can be found on page 38-40.

Note: Intermittent pressure drop and oil flow must not occur simultaneously.

SHAFT VERSION

A: Cylindrical shaft
25 mm
D: Parallel key
A8 × 7 × 32
DIN 6885

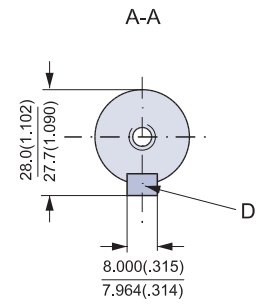
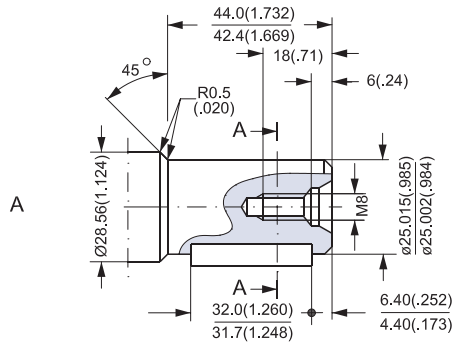

B: Cylindrical shaft
1 in
E: Parallel key
1/4 × 1/4 × 1 1/4 in
B.S. 46

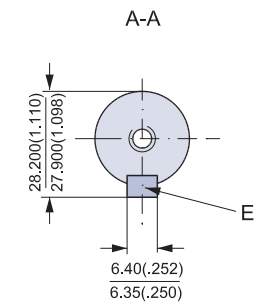
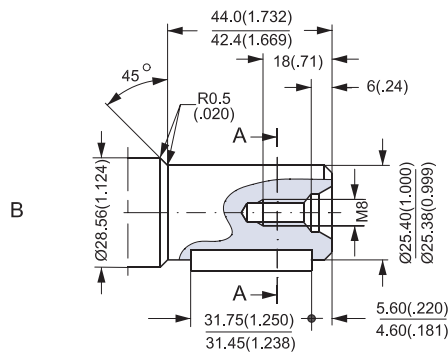

US version
C: Cylindrical shaft
1 in
F: Parallel key
1/4 × 1/4 × 1 1/4 in
B.S. 46

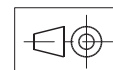
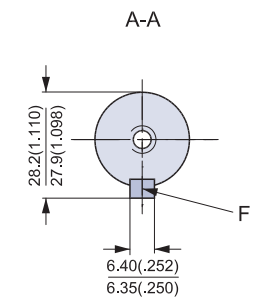
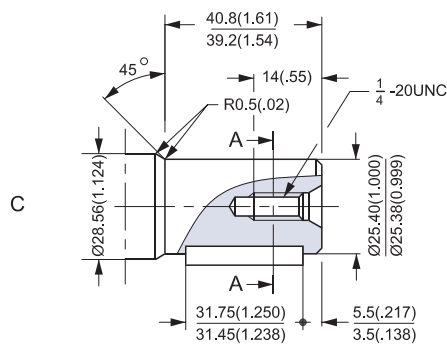

151-1846.10

SHAFT VERSION

D: Cylindrical shaft
32 mm
G: Parallel key
A10 × 8 × 45
DIN 6885

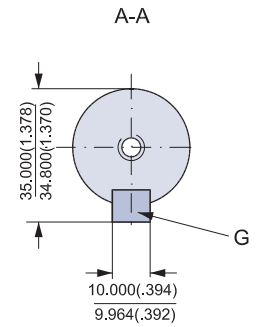
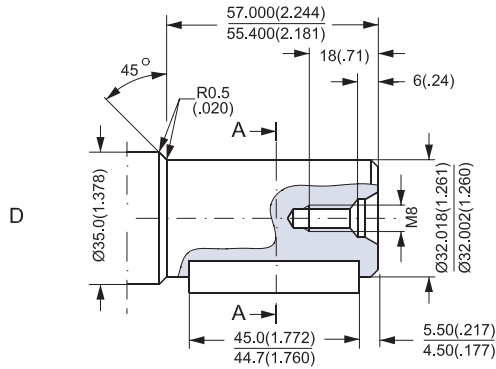

US version

E: Cylindrical shaft
1 1/4 in
H: Parallel key
5/16 × 5/16 × 1 1/4 in
B.S. 46

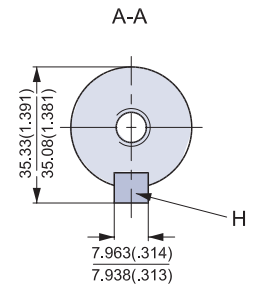
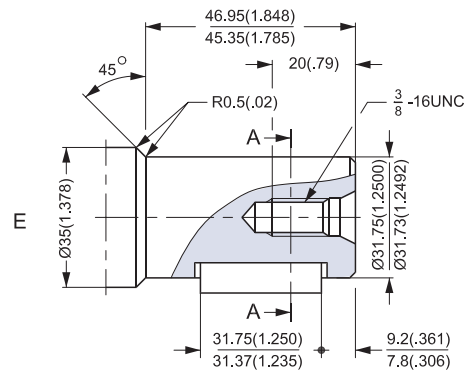

F: Involute splined shaft
B.S. 2059 (SAE 6 B)

Straight-sided,
bottom fitting, deep.
Fit 2
Nom. size 1 in

*Deviates from
B.S. 2059 (SAE 6 B)

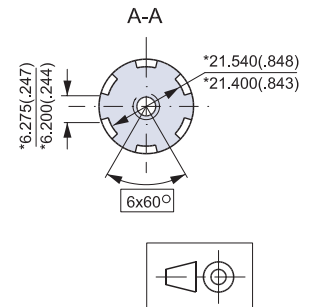
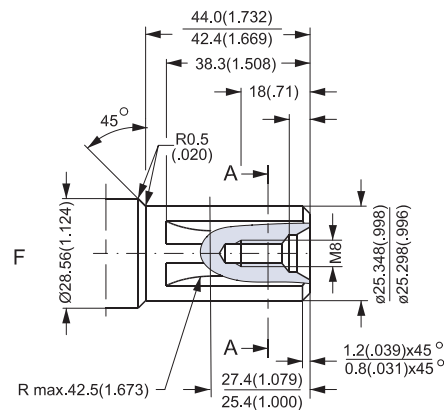

151-1851.10

SHAFT VERSION

US version

- G: Splined shaft
- SAE 6 B (B.S. 2059)
- Straight-sided,
- bottom fitting, deep.
- Fit 2
- Nom. size 1 in
- * Deviates from
- SAE 6 B (B.S. 2059)

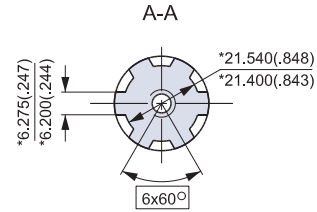
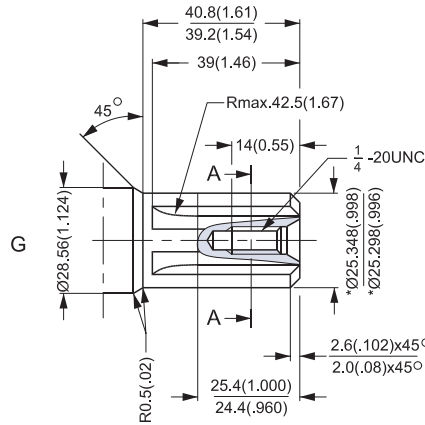

- H: Tapered shaft 28.5 mm (ISO/R775)
- K: DIN 937 NV 30
- Tightening torque: 100 ± 10 Nm (885 ± 85 lbf-in)
- J: Taper 1:10
- L: Parallel key B5 × 5 × 14 DIN 6885

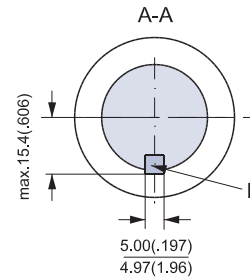
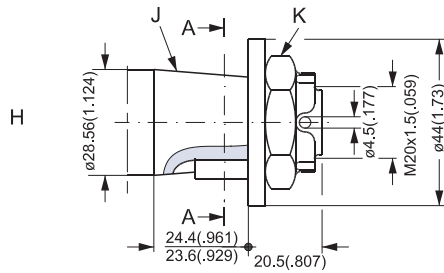

- I: Tapered shaft 35 mm (ISO/R775)
- N: DIN 937 NV 41
- Tightening torque: 200 ± 10 Nm (1770 ± 85 lbf-in)
- M: Taper 1:10
- P: Parallel key B6 × 6 × 20 DIN 6885

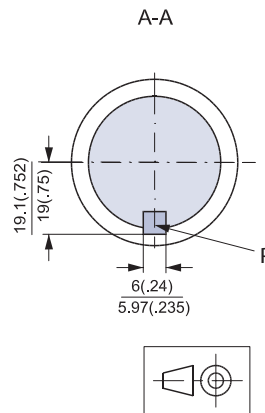
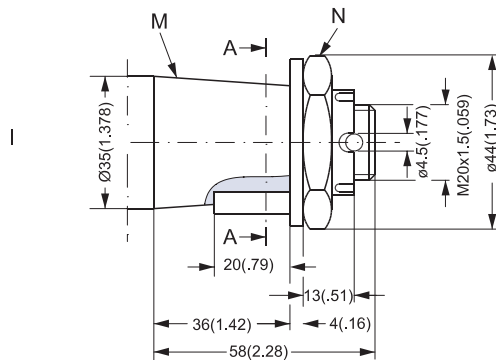

151-1847.10

SHAFT VERSION

- J: Tapered shaft 1 1/4 in
- K: Cone 1:8
SAE J501
- L: 1 - 20 UNEF
Across flats 1 7/16
Tightening torque:
200 ± 10 Nm (1770 ± 85 lbf·in)
- M: Parallel key
5/16 × 5/16 × 1 1/4
SAE J501

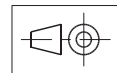
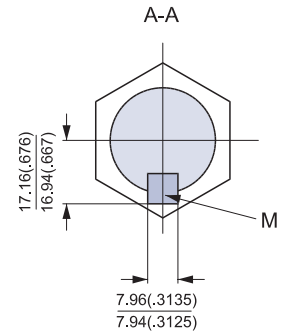
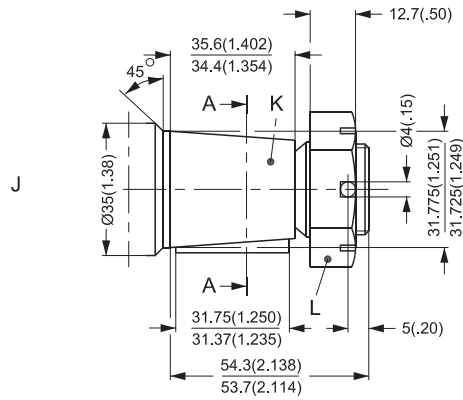

151-1848.10

PORT THREAD VERSIONS

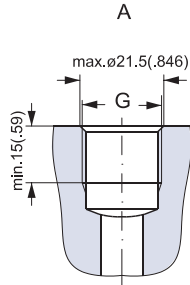

A: G main ports
G: ISO 228/1 - G¹/₂

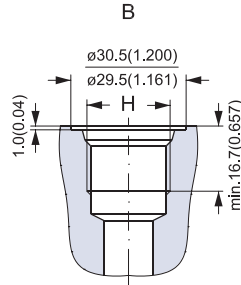

B: UNF main ports
H: ⁷/₈ - 14 UNF
O-ring boss port

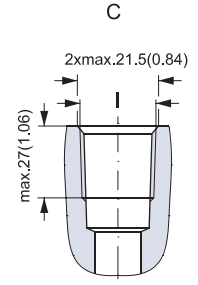

C: NPTF main ports
I: ¹/₂ - 14 NPTF

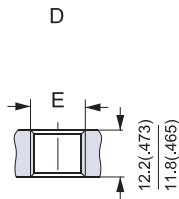

D: G drain port
E: ISO 228/1 - G¹/₄

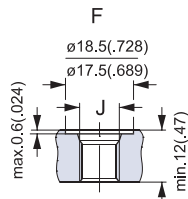

F: UNF drain port
J: ⁷/₁₆ - 20 UNF
O-ring boss port

151-1844.10

DIMENSIONS

Side port version with 2-hole oval mounting flange (A2 flange).
With high pressure shaft seal.

Type	L mm (in)	L ₁ mm (in)
OMR 50	135.5 (5.33)	9.0 (0.35)
OMR 80	140.5 (5.53)	14.0 (0.55)
OMR 100	144.0 (5.67)	17.4 (0.69)
OMR 125	148.5 (5.85)	21.8 (0.86)
OMR 160	154.5 (6.08)	27.8 (1.09)
OMR 200	161.5 (6.36)	34.8 (1.37)
OMR 250	170.5 (6.71)	43.5 (1.71)
OMR 315	181.5 (7.15)	54.8 (2.16)
OMR 375	191.7 (7.55)	65.0 (2.56)

D: G 1/2; 15 mm (0.59 in) deep
E: M8; 13 mm (0.51 in) deep
(4 pcs.)

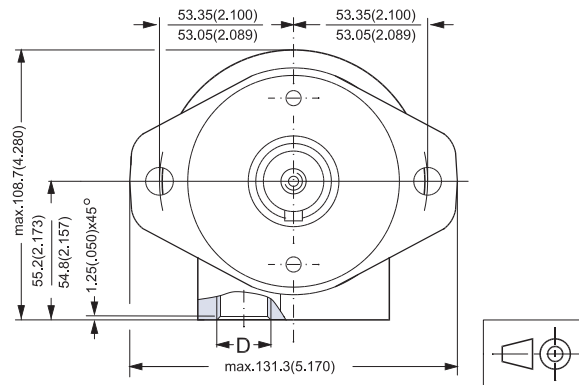
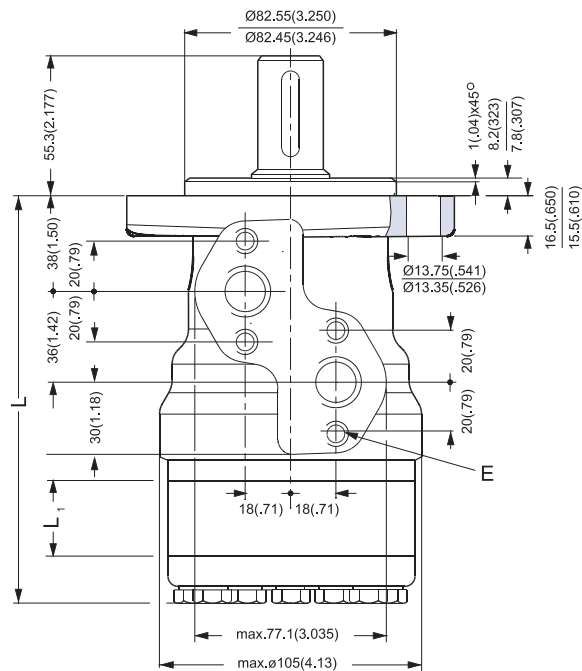

151-1750.10

DIMENSIONS

Side port version with 2-hole oval mounting flange (A2 flange).
With check valves and drain connection.
With high pressure shaft seal.

Type	L mm (in)	L ₁ mm (in)
OMR 50	135.5 (5.33)	9.0 (0.35)
OMR 80	140.5 (5.53)	14.0 (0.55)
OMR 100	144.0 (5.67)	17.4 (0.69)
OMR 125	148.5 (5.85)	21.8 (0.86)
OMR 160	154.5 (6.08)	27.8 (1.09)
OMR 200	161.5 (6.36)	34.8 (1.37)
OMR 250	170.5 (6.71)	43.5 (1.71)
OMR 315	181.5 (7.15)	54.8 (2.16)
OMR 375	191.7 (7.55)	65.0 (2.56)

- C: Drain connection
G 1/4; 12 mm (0.47 in) deep
- D: G 1/2; 15 mm (0.59 in) deep
- E: M8; 13 mm (0.51 in) deep
(4 pcs.)

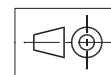
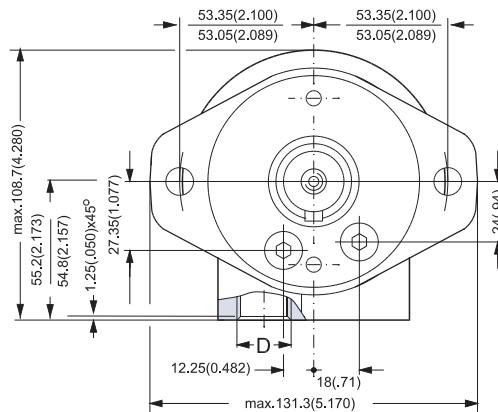
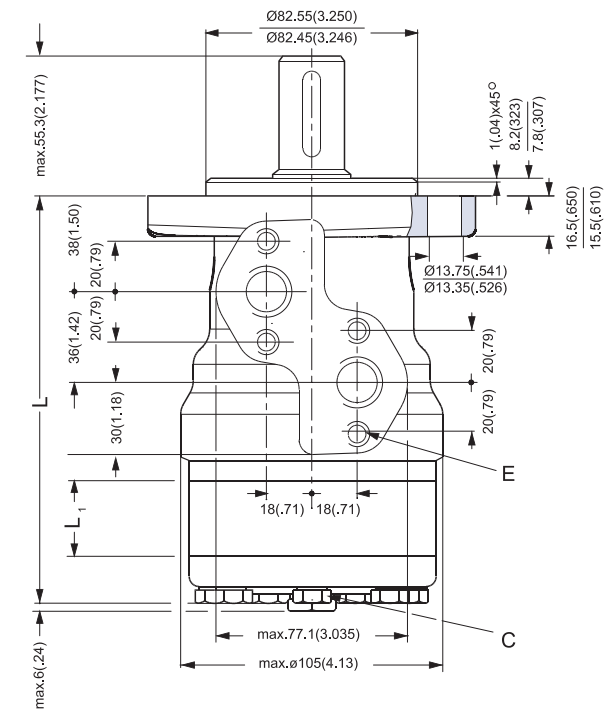

151-1845.10

DIMENSIONS

Side port version with 2-hole oval mounting flange (A2 flange).

Output shaft. max.	mm L ₂ (in)
Cylindrical shaft 32 mm (1.26 in)	68.3 (2.69)
Cylindrical shaft 25 mm	55.3 (2.16)
Tapered shaft 28.56 mm (1.12 in)	56.3 (2.19)

Type	L mm (in)	L ₁ mm (in)
OMR 50	135.5 (5.33)	9.0 (0.35)
OMR 80	140.5 (5.53)	14.0 (0.55)
OMR 100	144.0 (5.67)	17.4 (0.69)
OMR 125	148.5 (5.85)	21.8 (0.86)
OMR 160	154.5 (6.08)	27.8 (1.09)
OMR 200	161.5 (6.36)	34.8 (1.37)
OMR 250	170.5 (6.71)	43.5 (1.71)
OMR 315	181.5 (7.15)	54.8 (2.16)
OMR 375	191.7 (7.55)	65.0 (2.56)

- C: Drain connection
G 1/4; 12 mm (0.47 in) deep
- D: G 1/2; 15 mm (0.59 in) deep
- E: M8; 13 mm (0.51 in) deep
(4 pcs.)

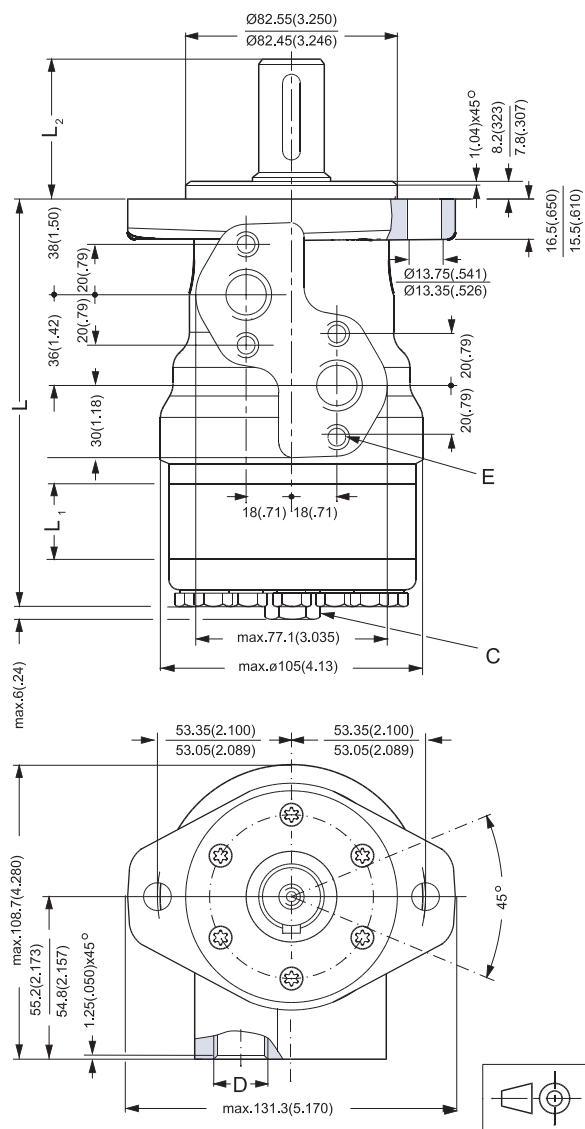

151-1849.10

DIMENSIONS

End port version with 2-hole oval mounting flange (A2-flange).

Type	L mm (in)	L ₁ mm (in)
OMR 50	150.6 (5.92)	9.0 (0.35)
OMR 80	155.6 (6.13)	14.0 (0.55)
OMR 100	159.0 (6.26)	17.4 (0.69)
OMR 125	163.4 (6.43)	21.8 (0.86)
OMR 160	169.4 (6.67)	27.8 (1.09)
OMR 200	176.4 (6.94)	34.8 (1.37)
OMR 250	185.1 (7.29)	43.5 (1.71)
OMR 315	196.4 (7.73)	54.8 (2.16)
OMR 400	206.6 (8.13)	65.0 (2.56)

C: Drain connection
G 1/4; 12 mm (0.47 in) deep
D: G 1/2; 15 mm (0.59 in) deep

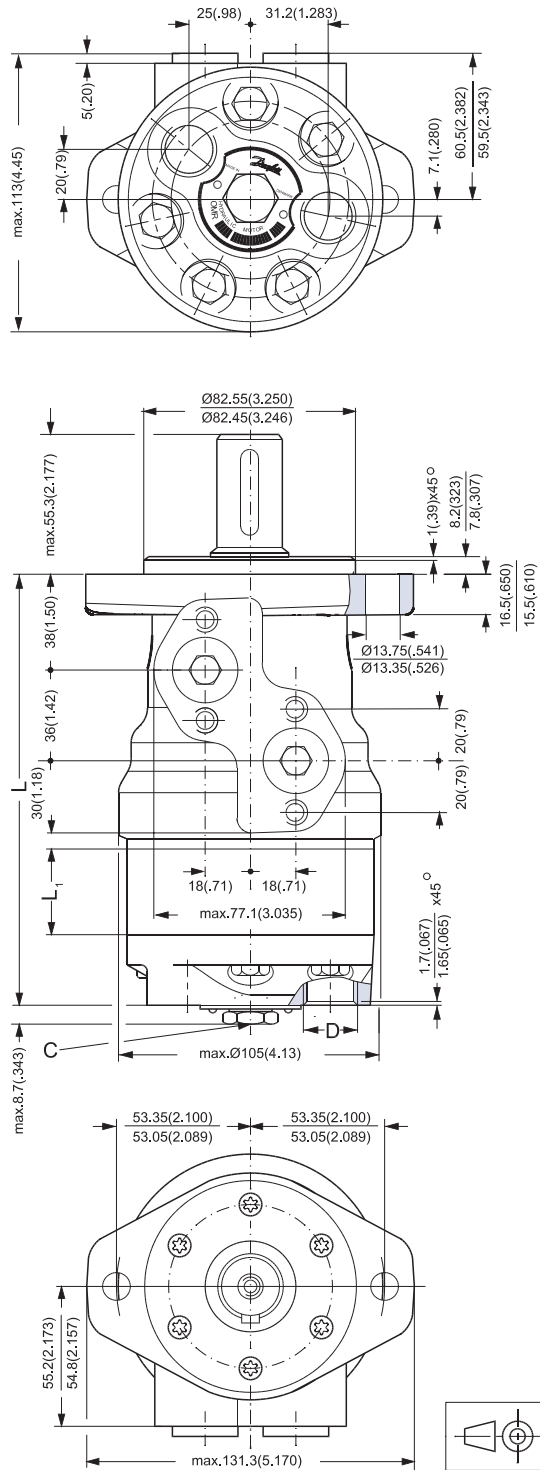

151-1752.10

DIMENSIONS

Side port version with 2-hole oval mounting flange (A2-flange).

Type	L mm (in)	L ₁ mm (in)
OMR 50	141.5 (5.57)	9.0 (0.35)
OMR 80	146.5 (5.77)	14.0 (0.55)
OMR 100	150.0 (5.91)	17.4 (0.69)
OMR 125	154.4 (6.08)	21.8 (0.86)
OMR 160	160.5 (6.32)	27.8 (1.09)
OMR 200	167.5 (6.59)	34.8 (1.37)
OMR 250	176.5 (6.95)	43.5 (1.71)
OMR 315	187.5 (7.38)	54.8 (2.16)
OMR 400	197.5 (7.78)	64.8 (2.55)

- C: Drain connection
7/16 - 20 UNF;
12 mm (0.47 in) deep
- D: 7/8 - 14 UNF;
16.76 mm (0.66 in) deep
- E: M8; 13 mm (0.51 in) deep
(4-off)

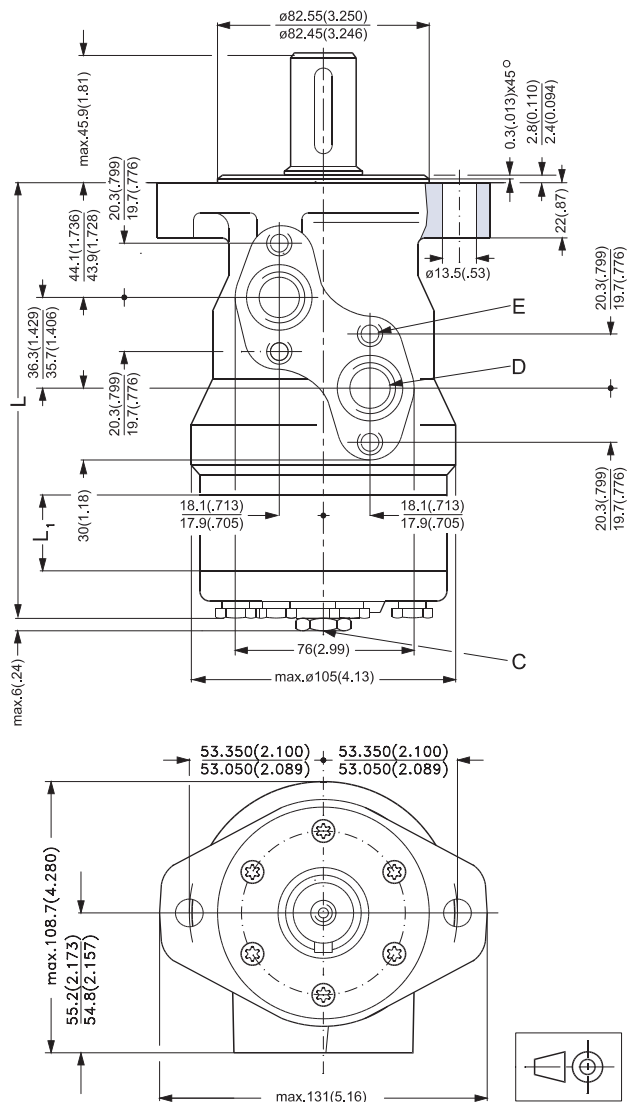

151-1223.10

DIMENSIONS

Side port version with 4-hole oval mounting flange (A4 flange).

Output shaft. max.	mm L ₂ (in)
Cylindrical shaft 32 mm (1.26 in)	68.3 (2.69)
Cylindrical shaft 25 mm (0.98 in)	55.3 (2.16)

Type	L mm (in)	L ₁ mm (in)
OMR 50	135.5 (5.33)	9.0 (0.35)
OMR 80	140.5 (5.53)	14.0 (0.55)
OMR 100	144.0 (5.67)	17.4 (0.69)
OMR 125	148.5 (5.85)	21.8 (0.86)
OMR 160	154.5 (6.08)	27.8 (1.09)
OMR 200	161.5 (6.36)	34.8 (1.37)
OMR 250	170.5 (6.71)	43.5 (1.71)
OMR 315	181.5 (7.15)	54.8 (2.16)
OMR 375	191.7 (7.55)	65.0 (2.56)

- C: Drain connection
G 1/4; 12 mm (0.47 in) deep
- D: G 1/2; 15 mm (0.59 in) deep
- E: M8; 13 mm (0.51 in) deep
(4 pcs.)

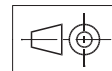
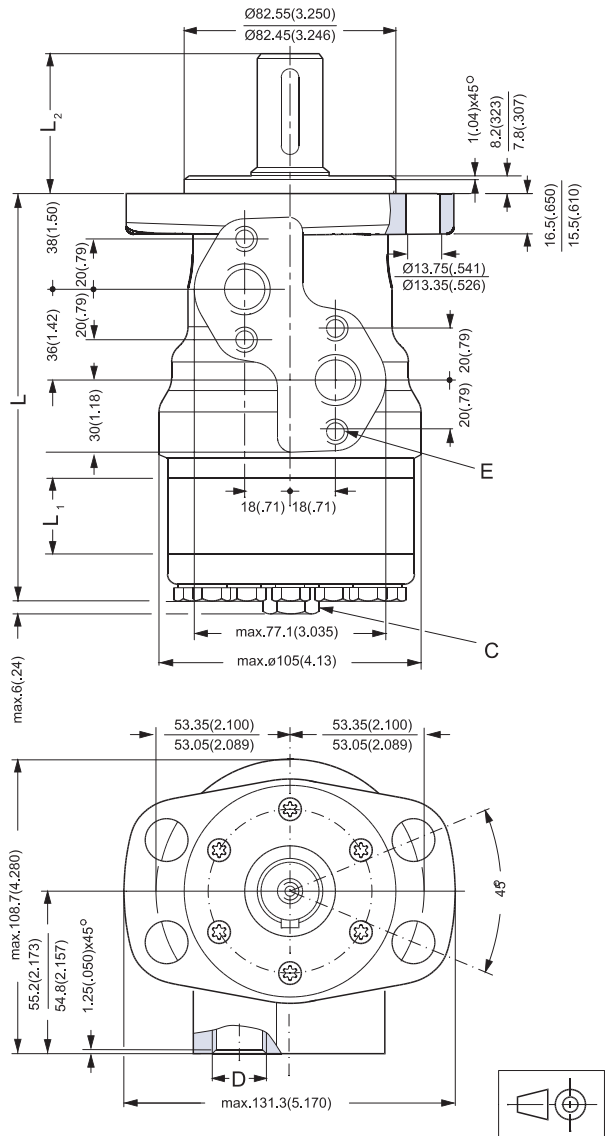

151-1751.10

DIMENSIONS

Side port version with 4-hole oval mounting flange (A4-flange).

Type	L mm (in)	L ₁ mm (in)
OMR 50	135.5 (5.33)	9.0 (0.35)
OMR 80	140.5 (5.53)	14.0 (0.55)
OMR 100	144.0 (5.67)	17.4 (0.69)
OMR 125	148.4 (5.84)	21.8 (0.86)
OMR 160	154.5 (6.08)	27.8 (1.09)
OMR 200	161.5 (6.36)	34.8 (1.37)
OMR 250	170.5 (6.71)	43.5 (1.71)
OMR 315	181.5 (7.15)	54.8 (2.16)
OMR 400	191.5 (7.55)	64.8 (2.55)

- C: Drain connection
7/16 - 20 UNF;
12 mm (0.47 in) deep
- D: 7/8 - 14 UNF;
16.76 mm (0.66 in) deep
- E: M8; 13 mm (0.51 in) deep
(4-off)

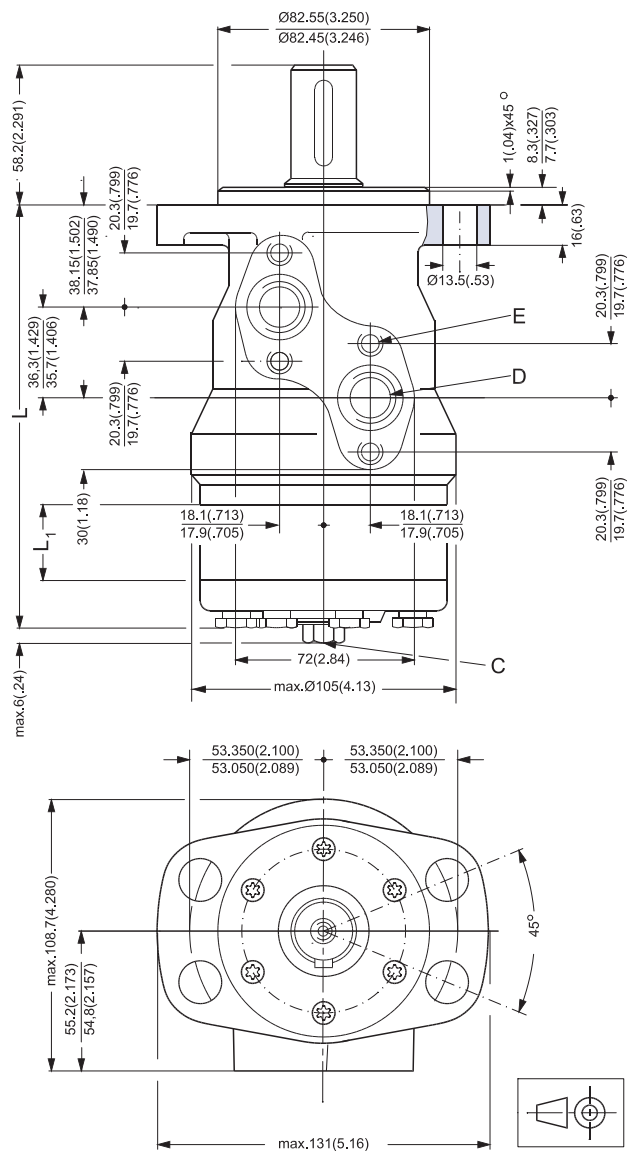

151-1221.10

DIMENSIONS

End port version with square mounting flange (C-flange).

Type	L mm (in)	L ₁ mm (in)
OMR 50	156.6 (6.17)	9.0 (0.35)
OMR 80	161.6 (6.36)	14.0 (0.55)
OMR 100	165.0 (6.50)	17.4 (0.69)
OMR 125	169.4 (6.67)	21.8 (0.86)
OMR 160	175.4 (6.91)	27.8 (1.09)
OMR 200	182.4 (7.18)	34.8 (1.37)
OMR 250	191.1 (7.52)	43.5 (1.71)
OMR 315	202.4 (7.98)	54.8 (2.16)
OMR 375	212.5 (8.37)	65.0 (2.56)

- C: Drain connection
G 1/4; 12 mm (0.47 in) deep
- D: G 1/2; 15 mm (0.59 in) deep
- E: M10; 15 mm (0.59 in) deep
(4 pcs.)

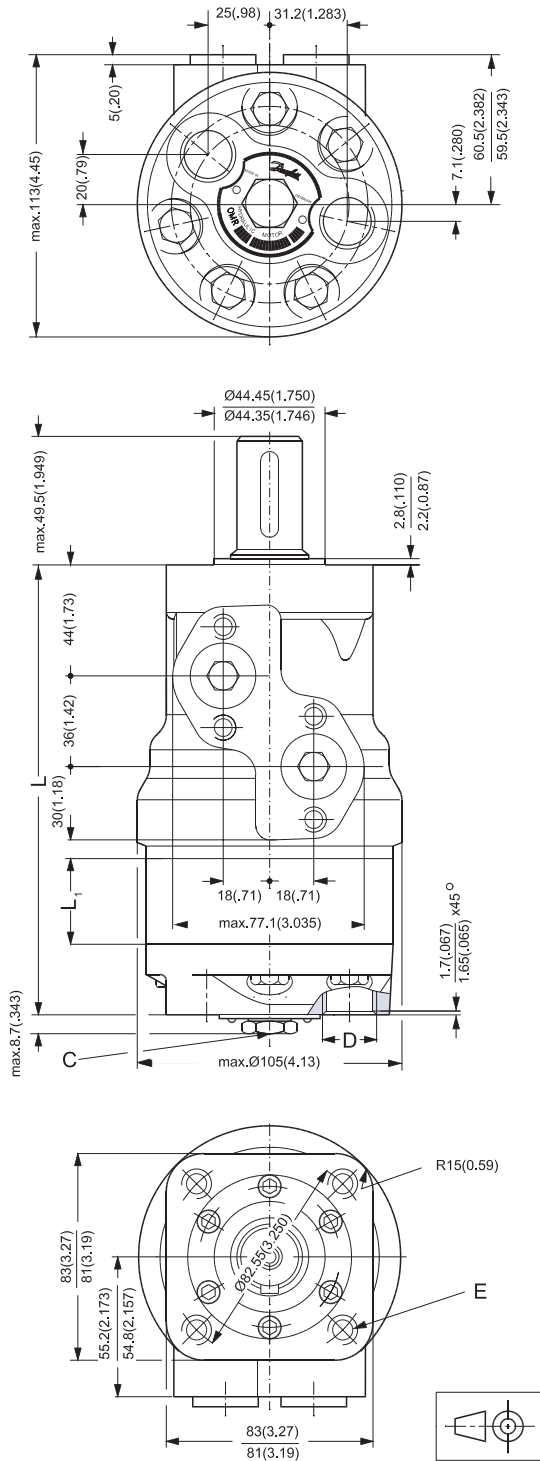

151-1753.10

DIMENSIONS

Side port version with square mounting flange (C-flange).

Type	L mm (in)	L ₁ mm (in)
OMR 50	141.5 (5.57)	9.0 (0.35)
OMR 80	146.5 (5.77)	14.0 (0.55)
OMR 100	150.0 (5.91)	17.4 (0.69)
OMR 125	154.4 (6.08)	21.8 (0.86)
OMR 160	160.5 (6.32)	27.8 (1.09)
OMR 200	167.5 (6.59)	34.8 (1.37)
OMR 250	176.5 (6.95)	43.5 (1.71)
OMR 315	187.5 (7.38)	54.8 (2.16)
OMR 375	197.7 (7.78)	64.8 (2.55)

- C: Drain connection
7/16 - 20 UNF;
12 mm (0.47 in) deep
- D: 7/8 - 14 UNF;
17 mm (0.66 in) deep
- E: M8; 13 mm (0.51 in) deep
(4-off)
- F: 3/8 - 16 UNC;
15 mm (0.59 in) deep
(4-off)

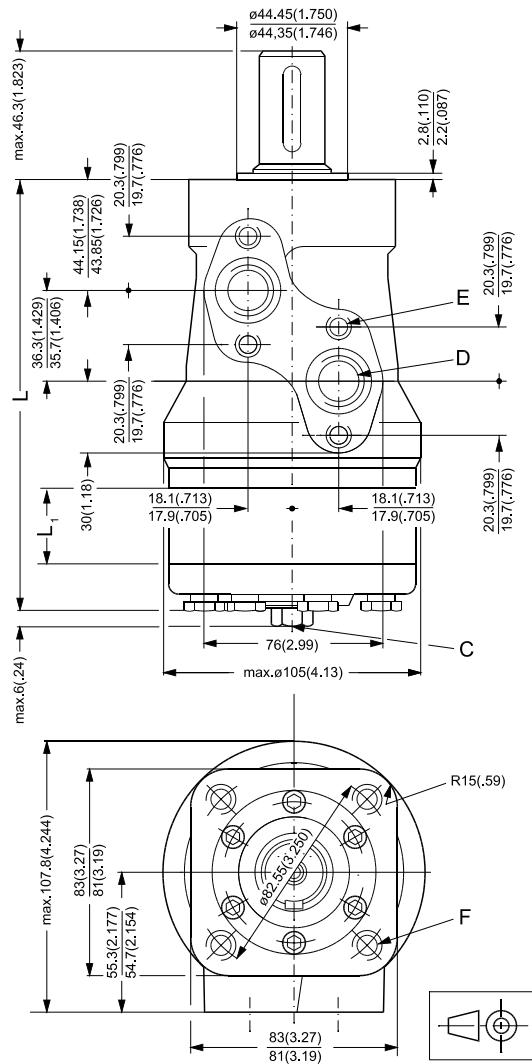

151-1220.10

DIMENSIONS
OMRW N

OMRW N wheel motor.

Type	L mm (in)	L ₁ mm (in)
OMRW 50N	106.0 (4.17)	9.0 (0.35)
OMRW 80N	111.0 (4.37)	14.0 (0.55)
OMRW 100N	114.4 (4.50)	17.4 (0.69)
OMRW 125N	118.8 (4.68)	21.8 (0.86)
OMRW 160N	124.8 (4.91)	27.8 (1.09)
OMRW 200N	131.8 (5.19)	34.8 (1.37)
OMRW 250N	140.5 (5.53)	43.5 (1.71)
OMRW 315N	152.0 (5.98)	54.8 (2.16)
OMRW 375N	162.0 (6.38)	65.0 (2.56)

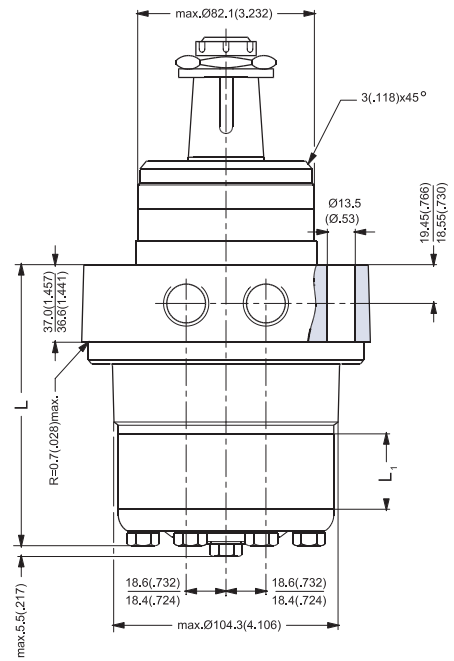
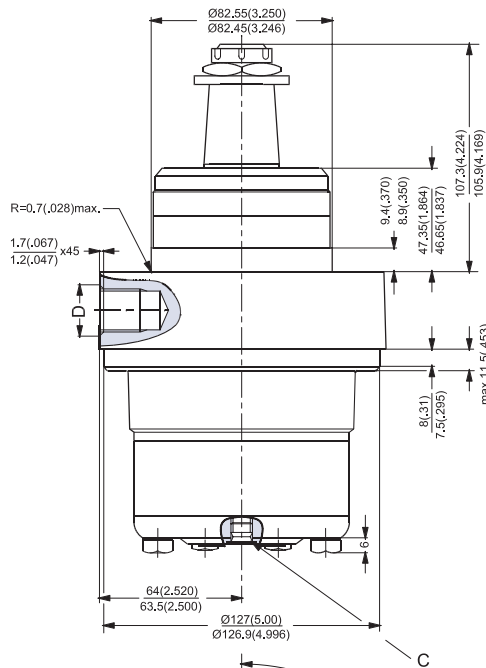

C: Drain connection
G 1/4; 12 mm (0.47 in) deep
D: G 1/2; 15 mm (0.59 in) deep

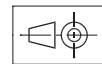
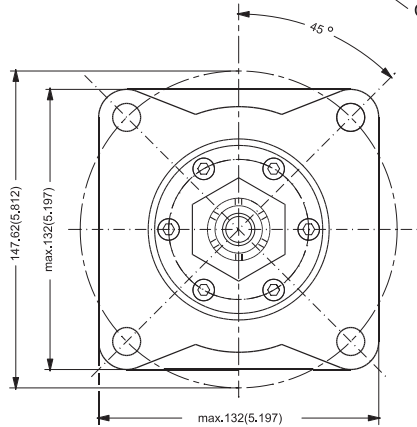

151-1386.10

DIMENSIONS
OMRW N

OMRW N wheel motor.

Type	L mm (in)	L ₁ mm (in)
OMRW 50N	106.0 (4.17)	9.0 (0.35)
OMRW 80N	111.0 (4.37)	14.0 (0.55)
OMRW 100N	114.4 (4.50)	17.4 (0.69)
OMRW 125N	118.8 (4.68)	21.8 (0.86)
OMRW 160N	124.8 (4.91)	27.8 (1.09)
OMRW 200N	131.8 (5.19)	34.8 (1.37)
OMRW 250N	140.5 (5.53)	43.5 (1.71)
OMRW 315N	152.0 (5.98)	54.8 (2.16)
OMRW 375N	162.0 (6.38)	65.0 (2.56)

- C: Drain connection
7/16 - 20 UNF
12 mm (0.47 in) deep
- D: 7/8 - 14 UNF
17 mm (0.66 in) deep

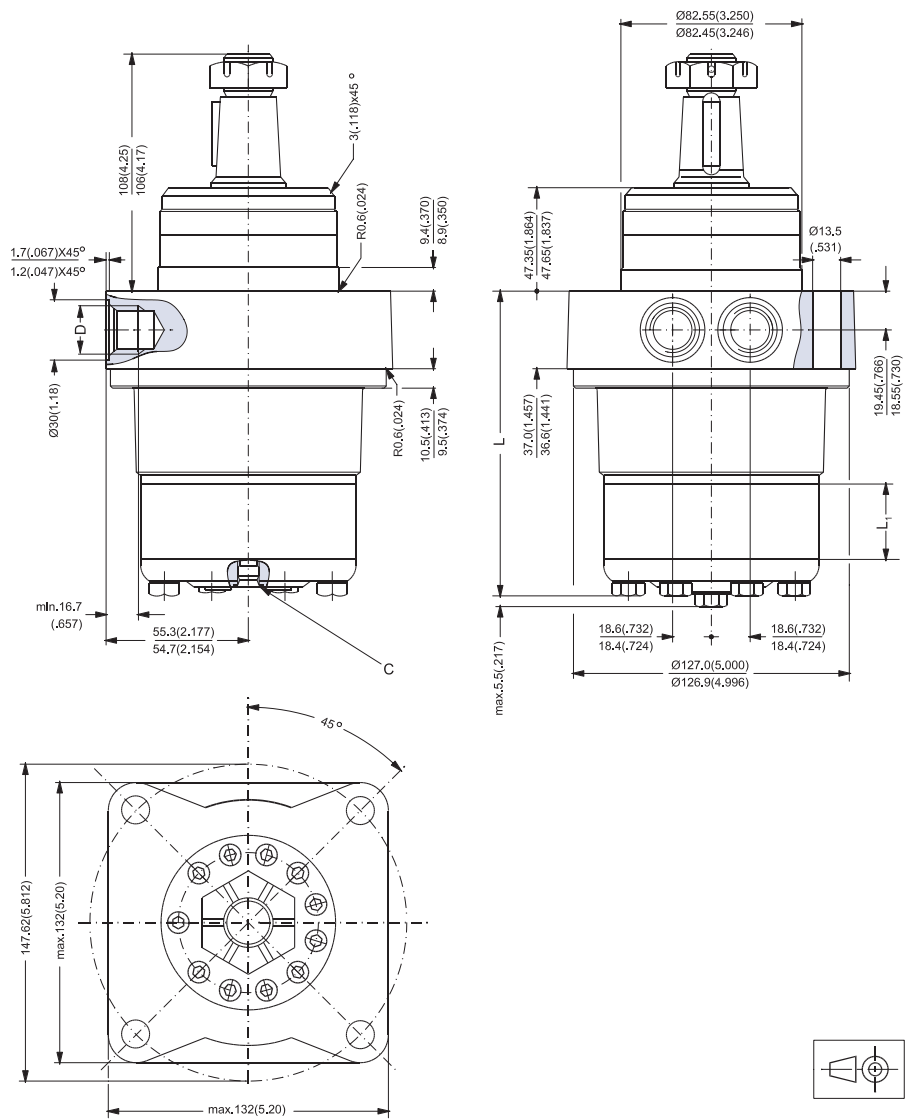

151-1625.10

VERSIONS

Mounting flange	Shaft	Port size	European version	US version	Side port version	End port version	Flange port version	Standard shaft seal	High pressure shaft seal	Drain connection	Check valve	Specials	Main type designation
4 hole oval flange (A4-flange)	Cyl. 32 mm	G 1/2	X		X			X		Yes	Yes		OMH
	Cyl. 35 mm	G 1/2	X		X			X		Yes	Yes		OMH
	Cyl. 1 1/4 in	7/8 - 14 UNF		X	X			X		Yes	Yes		OMH
	Splined 1" SAE 6B	7/8 - 14 UNF		X	X			X		Yes	Yes		OMH
	Splined 1 1/4 in	G 1/2	X		X			X		Yes	Yes		OMH
	Splined 1 1/4 in	7/8 - 14 UNF		X	X			X		Yes	Yes		OMH
	Tapered 35 mm	G 1/2	X		X			X		Yes	Yes		OMH
Function diagram – see page : →													

Features available (options) :
Painted

CODE NUMBERS

CODE NUMBERS	DISPLACEMENT [cm ³]					Technical data – Page	Dimensions – Page
	200	250	315	400	500		
151H	1002	1003	1004	1005	1006	69	81
151H	1012	1013	1014	1015	1016	70	81
151H	1042	1043	1044	1045	1046	69	82
151H	1080	1082	1083	1084	1081	68	82
151H	1022	1023	1024	1025	1026	70	81
151H	1052	1053	1054	1055	1056	70	82
151H	-	-	1034	1035	1036	70	81
	74	74	75	75	76		

Ordering

Add the four digit prefix “151H” to the four digit numbers from the chart for complete code number.

Example:

151H1044 for an OMH 315 with A4 flange, cyl. 1 1/4 in shaft, port size 7/8 - 14 UNF.

Note: Orders will not be accepted without the four digit prefix.

TECHNICAL DATA FOR OMH WITH 1 IN SAE 6 B SPLINED SHAFT

Type			OMH	OMH	OMH	OMH	OMH
Motor size			200	250	315	400	500
Geometric displacement	cm ³ (in ³)		201.3 (12.32)	252.0 (15.42)	314.9 (19.27)	396.8 (24.28)	470.6 (28.80)
Max. speed	min ⁻¹ (rpm)	cont.	370	295	235	185	155
		int. ¹⁾	445	350	285	225	190
Max. torque	Nm (lbf-in)	cont.	340 (3000)	340 (3000)	340 (3000)	340 (3000)	340 (3000)
		int. ¹⁾	510 (4500)	510 (4500)	540 (4800)	540 (4800)	540 (4600)
		peak ²⁾	640 (5650)	785 (6950)	835 (7400)	835 (7400)	835 (7400)
Max. output	kW (hp)	cont.	11.2 (15.0)	7.5 (10.0)	5.2 (7.0)	4.8 (6.5)	3.7 (5.0)
		int. ¹⁾	17.2 (23.0)	11.9 (16.0)	9.7 (13.0)	8.2 (11.0)	6.0 (8.0)
Max. pressure drop	bar (psi)	cont.	115 (1650)	90 (1300)	75 (1100)	60 (900)	50 (725)
		int. ¹⁾	170 (2500)	145 (2100)	120 (1750)	95 (1400)	75 (1100)
		peak ²⁾	225 (3300)	225 (3300)	185 (2700)	155 (2250)	160 (2300)
Max. oil flow	l/min (US gal/min)	cont.	75 (19.8)	75 (19.8)	75 (19.8)	75 (19.8)	75 (19.8)
		int. ¹⁾	90 (23.8)	90 (23.8)	90 (23.8)	90 (23.8)	90 (23.8)
Max. starting pressure with unloaded shaft	bar (psi)		7 (100)	7 (100)	7 (100)	7 (100)	7 (100)
Min. starting torque	Nm (lbf-in)	at max. press. drop cont.	255 (2250)	270 (2400)	280 (2500)	290 (2550)	300 (2650)
		at max. press. drop int. ¹⁾	390 (3450)	435 (3850)	450 (4000)	450 (4000)	450 (4000)
Min. speed ³⁾	min ⁻¹ (rpm)		10	10	8	5	5

¹⁾ Intermittent operation: the permissible values may occur for max. 10% of every minute.

²⁾ Peak load: the permissible values may occur for max. 1% of every minute.

³⁾ Operation at lower speeds may be slightly less smooth.

TECHNICAL DATA FOR OMH WITH 32 MM AND 1 1/4 IN CYLINDRICAL SHAFT

Type			OMH	OMH	OMH	OMH	OMH
Motor size			200	250	315	400	500
Geometric displacement	cm ³ (in ³)		201.3 (12.32)	252.0 (15.42)	314.9 (19.27)	396.8 (24.28)	470.6 (28.80)
Max. speed	min ⁻¹ (rpm)	cont.	370	295	235	185	155
		int. ¹⁾	445	350	285	225	190
Max. torque	Nm (lbf-in)	cont.	510 (4510)	610 (5400)	590 (5220)	590 (5220)	580 (5130)
		int. ¹⁾	580 (5130)	700 (6200)	670 (5930)	700 (6200)	680 (6020)
		peak ²⁾	640 (5660)	790 (6990)	840 (7440)	840 (7440)	840 (7440)
Max. output	kW (hp)	cont.	16.0 (21.5)	16.0 (21.5)	12.5 (16.8)	10.0 (13.4)	8.5 (11.4)
		int. ¹⁾	18.5 (24.8)	18.5 (24.8)	14.0 (18.8)	12.0 (16.1)	10.0 (13.4)
Max. pressure drop	bar (psi)	cont.	175 (2540)	175 (2540)	135 (1960)	105 (1520)	85 (1230)
		int. ¹⁾	200 (2900)	200 (2900)	155 (2250)	125 (1810)	100 (1450)
		peak ²⁾	225 (3260)	225 (3260)	190 (2760)	155 (2250)	130 (1890)
Max. oil flow	l/min (US gal/min)	cont.	75 (19.8)	75 (19.8)	75 (19.8)	75 (19.8)	75 (19.8)
		int. ¹⁾	90 (23.8)	90 (23.8)	90 (23.8)	90 (23.8)	90 (23.8)
Max. starting pressure with unloaded shaft	bar (psi)		5 (75)	5 (75)	5 (75)	5 (75)	5 (75)
Min. starting torque	at max. press. drop	cont.	390 (3450)	520 (4600)	510 (4510)	490 (4340)	490 (4340)
	at max. press. drop	int. ¹⁾	450 (3980)	590 (5220)	590 (5220)	600 (5310)	600 (5310)
Min. speed ³⁾	min ⁻¹ (rpm)		10	10	8	5	5

¹⁾ Intermittent operation: the permissible values may occur for max. 10% of every minute.

²⁾ Peak load: the permissible values may occur for max. 1% of every minute.

³⁾ Operation at lower speeds may be slightly less smooth.

TECHNICAL DATA FOR OMH WITH 35 MM CYLINDRICAL, 1 1/4 IN SPLINED AND 35 MM TAPERED SHAFT

Type			OMH	OMH	OMH	OMH	OMH
Motor size			200	250	315	400	500
Geometric displacement	cm ³ (in ³)		201.3 (2.32)	252.0 (15.42)	314.9 (19.27)	396.8 (24.28)	470.6 (28.80)
Max. speed	min ⁻¹ (rpm)	cont.	370	295	235	185	155
		int. ¹⁾	445	350	285	225	190
Max. torque	Nm (lbf-in)	cont.	510 (4510)	610 (5400)	740 (6550)	840 (7440)	820 (7260)
		int. ¹⁾	580 (5130)	700 (6200)	820 (7260)	980 (8670)	1040 (9210)
		peak ²⁾	640 (5660)	790 (6990)	980 (8670)	1090 (9650)	1170 (10360)
Max. output	kW (hp)	cont.	16.0 (21.5)	16.0 (21.5)	14.0 (18.8)	12.5 (16.8)	11.0 (14.8)
		int. ¹⁾	18.5 (24.8)	18.5 (24.8)	15.5 (20.8)	15.0 (20.1)	14.0 (18.8)
Max. pressure drop	bar (psi)	cont.	175 (2540)	175 (2540)	175 (2540)	155 (2250)	125 (1810)
		int. ¹⁾	200 (2900)	200 (2900)	200 (2900)	190 (2760)	160 (2320)
		peak ²⁾	225 (3260)	225 (3260)	225 (3260)	210 (3050)	180 (2610)
Max. oil flow	l/min (US gal/min)	cont.	75 (19.8)	75 (19.8)	75 (19.8)	75 (19.8)	75 (19.8)
		int. ¹⁾	90 (23.8)	90 (23.8)	90 (23.8)	90 (23.8)	90 (23.8)
Max. starting pressure with unloaded shaft	bar (psi)		5 (75)	5 (75)	5 (75)	5 (75)	5 (75)
Min. starting torque	at max. press. drop cont.		390 (3450)	520 (4600)	660 (5840)	720 (6370)	720 (6370)
	at max. press. drop int. ¹⁾		450 (3980)	590 (5220)	730 (6460)	880 (7790)	880 (7790)
Min. speed ³⁾	min ⁻¹ (rpm)		10	10	8	5	5

Type			Max. inlet pressure	Max. return pressure with drain line
OMH 200 - 500	bar (psi)	cont.	200 (2900)	175 (2540)
	bar (psi)	int. ¹⁾	225 (3260)	200 (2900)
	bar (psi)	peak ²⁾	250 (3630)	225 (3260)

¹⁾ Intermittent operation: the permissible values may occur for max. 10% of every minute.

²⁾ Peak load: the permissible values may occur for max. 1% of every minute.

³⁾ Operation at lower speeds may be slightly less smooth.

**MAX. PERMISSIBLE
SHAFT SEAL PRESSURE**

OMH with standard shaft seal, check valves and without use of drain connection:
The pressure on the shaft seal never exceeds the pressure in the return line

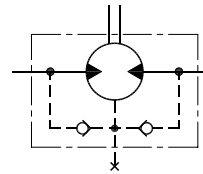

OMH with standard shaft seal, check valves and with drain connection:
The shaft seal pressure equals the pressure on the drain line.

151-320.10

Max. return pressure without drain line or max. pressure in the drain line

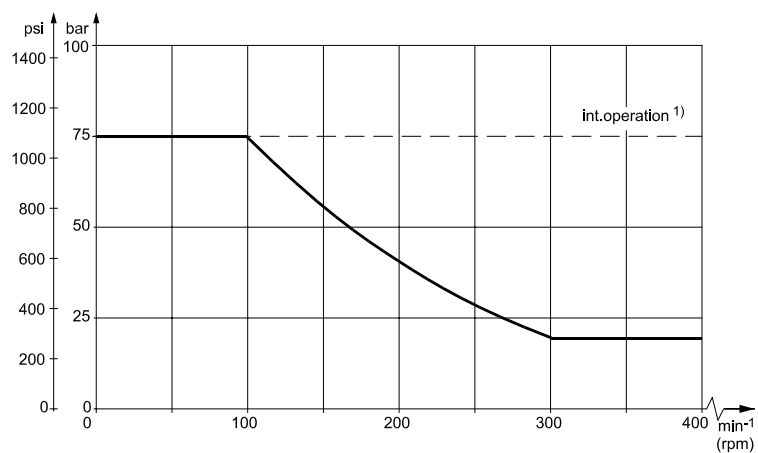

151-1565.10

¹⁾ Intermittent operation: the permissible values may occur for max. 10% of every minute.

PRESSURE DROP IN MOTOR

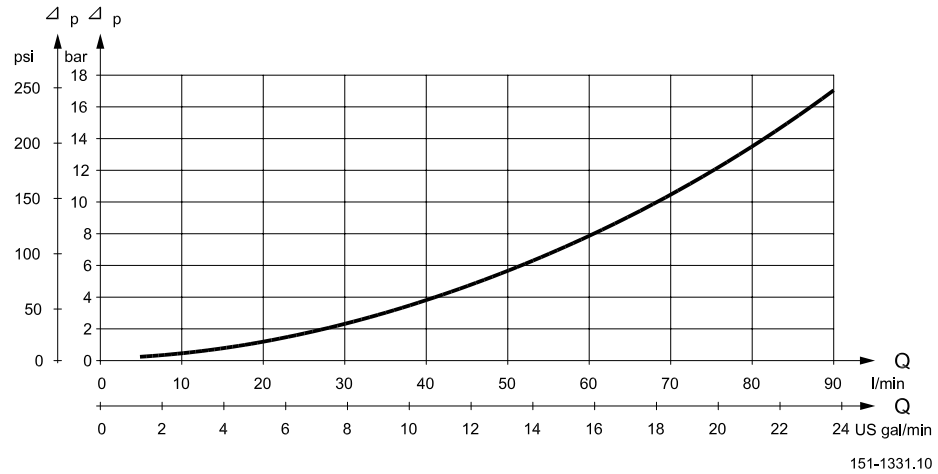

151-1331.10

The curve applies to an unloaded motor shaft and an oil viscosity of 35 mm²/s (165 SUS)

OIL FLOW IN DRAIN LINE

The table shows the max. oil flow in the drain line at a return pressure less than 5-10 bar (75-150 psi).

Pressure drop bar (psi)	Viscosity mm ² /s (SUS)	Oil flow in drain line l/min (US gal/min)
100 (1450)	20 (100)	2.5 (0.66)
	35 (165)	1.8 (0.78)
140 (2030)	20 (100)	3.5 (0.93)
	35 (165)	2.8 (0.74)

DIRECTION OF SHAFT ROTATION

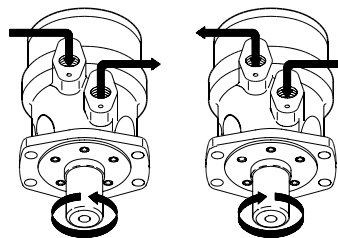

151-1839.10

**PERMISSIBLE SHAFT
LOADS FOR OMH**

The permissible shaft load (P_{rad}) is calculated from the speed (n) and the distance (l) between the point of load application and the mounting flange.

$$P_{rad} = \frac{1100}{n} \times \frac{250000}{103.5 + l} \text{ N}^*; l \text{ in mm}$$

$$P_{rad} = \frac{1100}{n} \times \frac{2215}{4.07 + l} \text{ lbf}^*; l \text{ in inch}$$

* $n > 200 \text{ min}^{-1} \text{ (rpm)}$; $l < 60 \text{ mm (2.36 in)}$
 $n < 200 \text{ min}^{-1} \text{ (rpm)}$; $\Rightarrow P_{rmax} = 11000 \text{ N (2475 lbf)}$

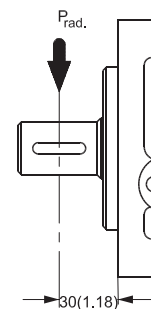
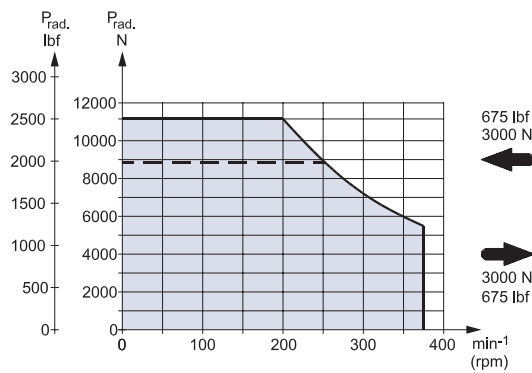

151-1474.10

----- 1 in SAE 6B splined shaft

The drawing shows the permissible radial load when $l = 30 \text{ mm (1.18 in)}$.

FUNCTION DIAGRAMS

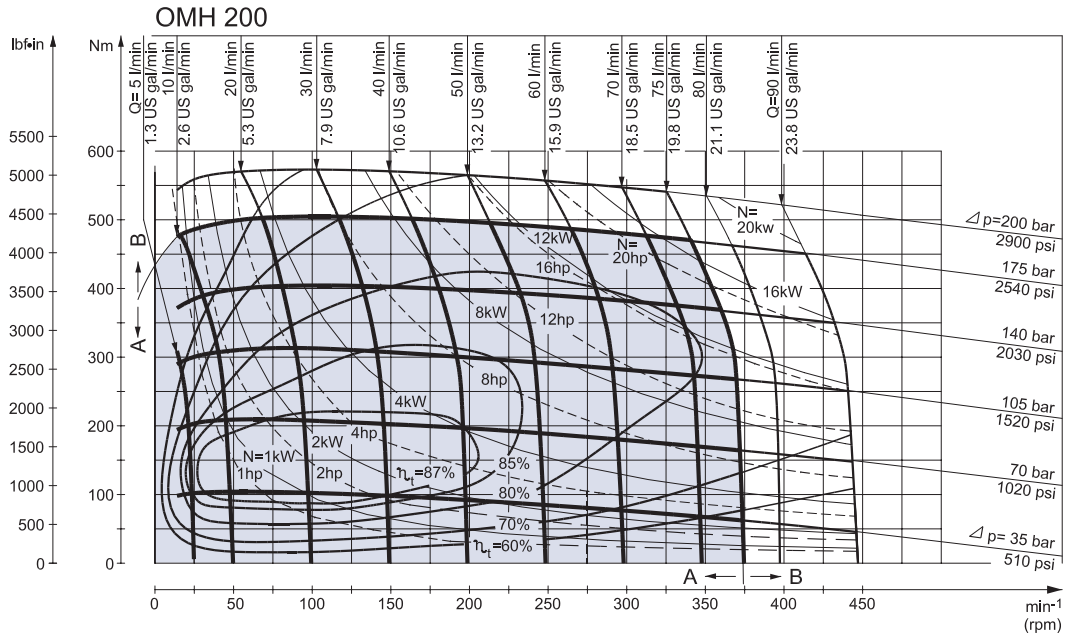

151-1486.10

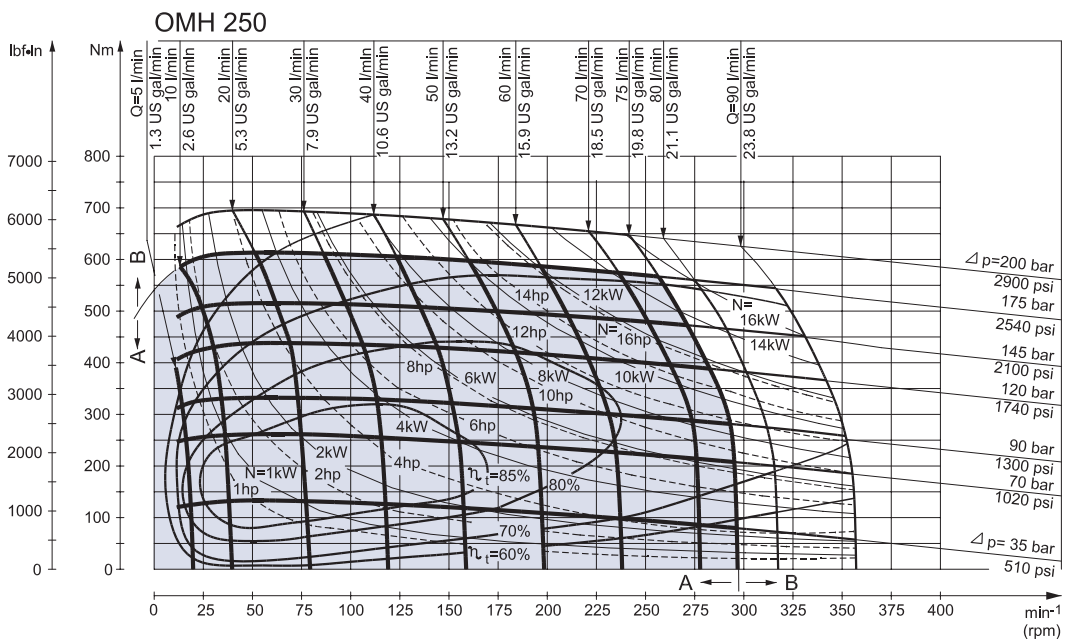

151-1487.10

Explanation of function diagram use, basis and conditions can be found on page 7.

- A: Continuous range
- B: Intermittent range (max. 10% operation every minute)

Max. permissible continuous/intermittent pressure drop for the actual shaft version can be found on page 68-70.

Note: Intermittent pressure drop and oil flow must not occur simultaneously.

FUNCTION DIAGRAMS

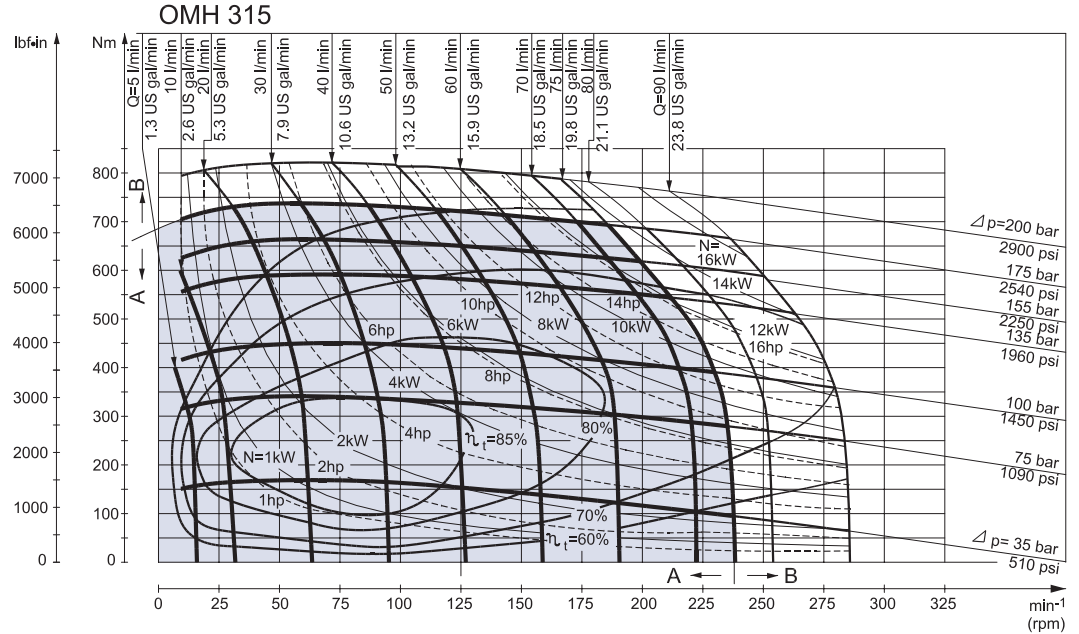

151-1488.10

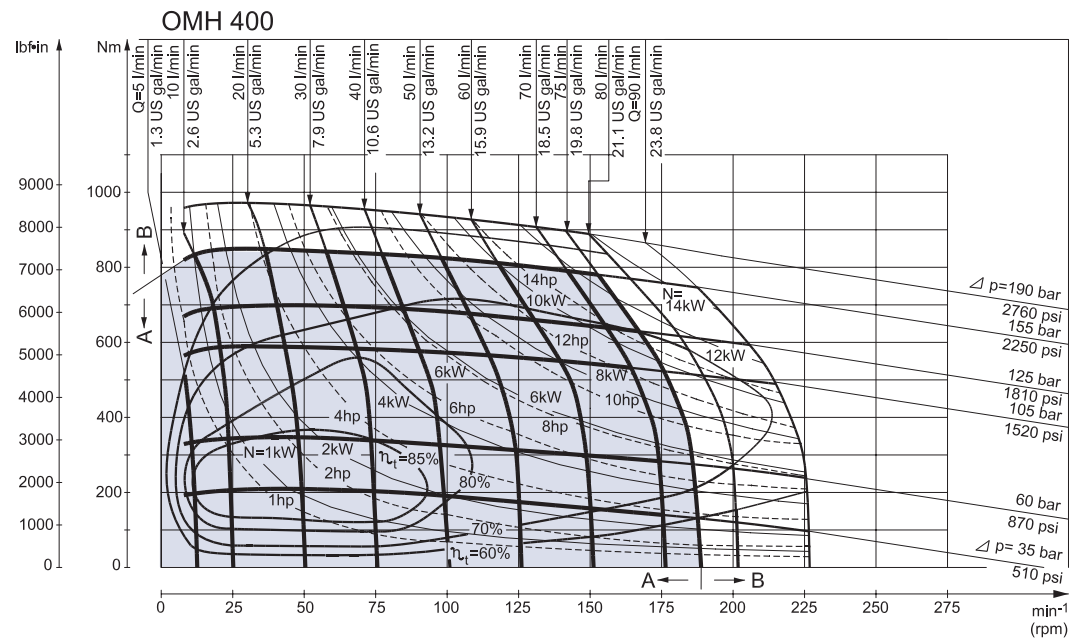

151-1489.10

Explanation of function diagram use, basis and conditions can be found on page 7.

- A: Continuous range
- B: Intermittent range (max. 10% operation every minute)

Max. permissible continuous/intermittent pressure drop for the actual shaft version can be found on page 68-70.

Note: Intermittent pressure drop and oil flow must not occur simultaneously.

FUNCTION DIAGRAMS

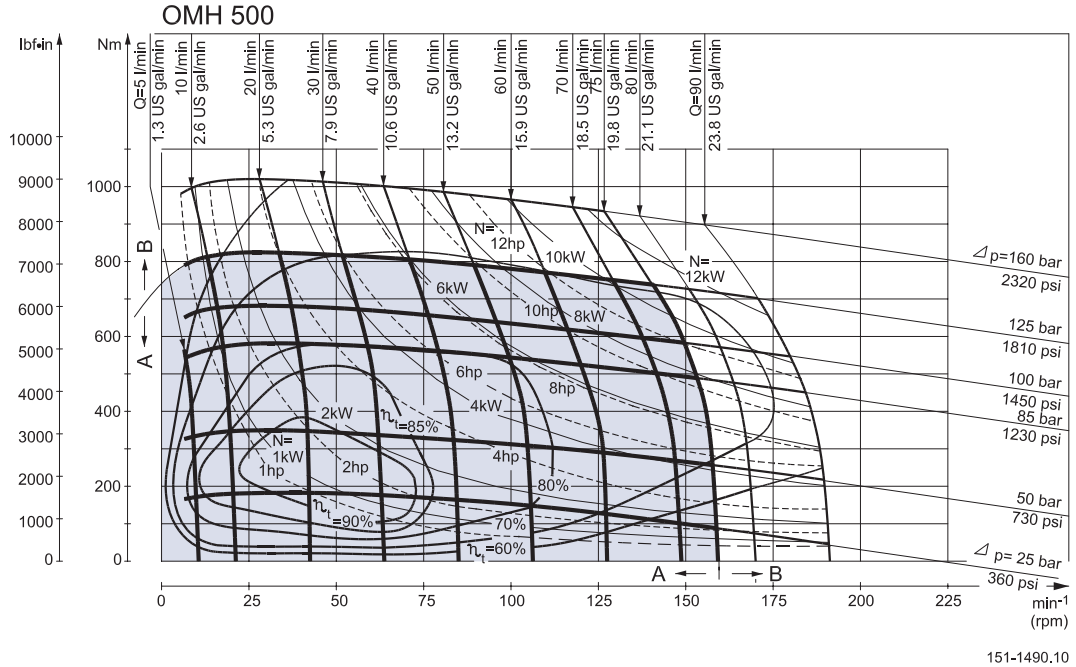

151-1490.10

Explanation of function diagram use, basis and conditions can be found on page 7.

- A: Continuous range
- B: Intermittent range (max. 10% operation every minute)

Max. permissible continuous/intermittent pressure drop for the actual shaft version can be found on page 68-70.

Note: Intermittent pressure drop and oil flow must not occur simultaneously.

SHAFT VERSION

- A: Cylindrical shaft
32 mm
D: Parallel key
A10 × 8 × 45
DIN 6885

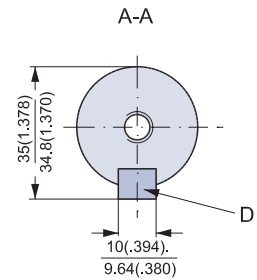
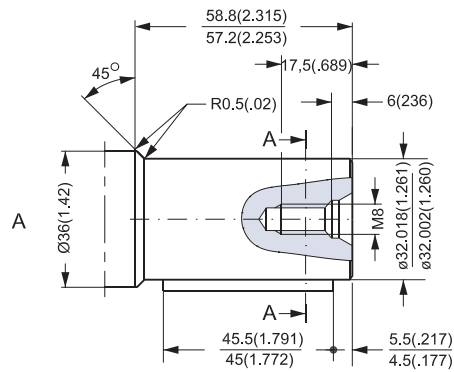

- B: Cylindrical shaft
35 mm
E: Parallel key
A10 × 8 × 45
DIN 6885

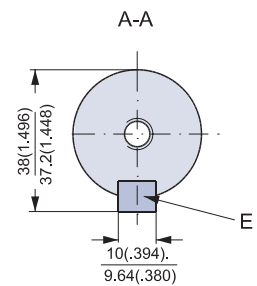
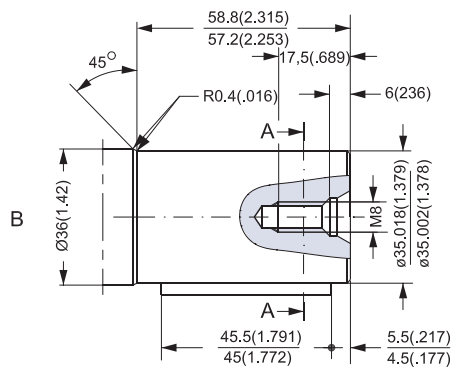

- US version**
C: Cylindrical shaft
1 1/4 in
F: Parallel key
5/16 × 5/16 × 1 1/4 in
SAE J 744

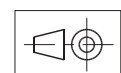
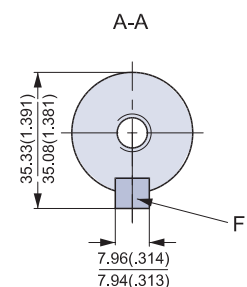
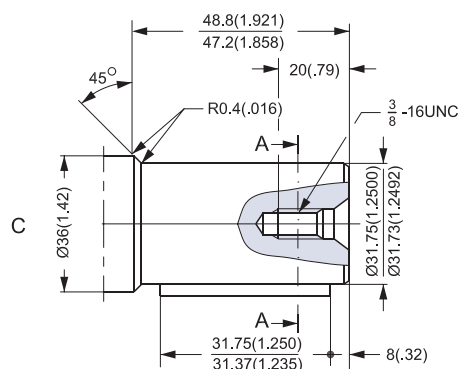

151-1852.10

SHAFT VERSION

D: Splined shaft
SAE 6 B (B.S. 2059)
Straight-sided,
bottom fitting, deep.
Fit 2
Nom. size 1 in

*Deviates from
SAE 6 B (B.S. 2059)

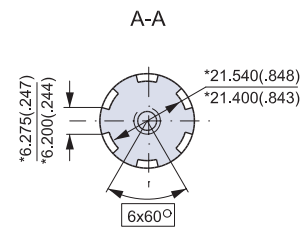
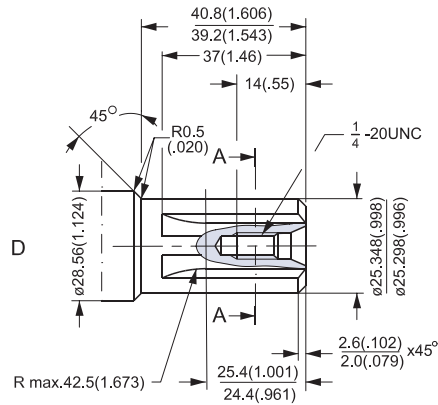

E: Involute splined shaft
ANS B92.1 - 1980 standard
Flat root side fit
Pitch 12/24
Teeth 14
Major dia. 1.25 in
Pressure angle 30°

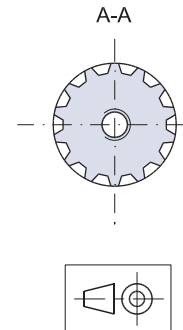
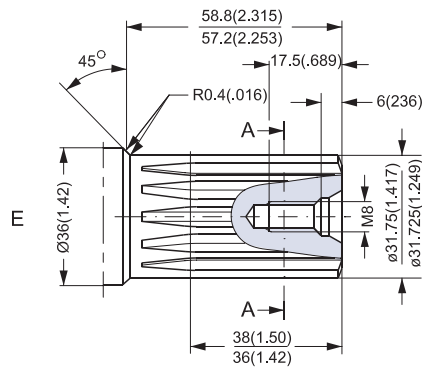

151-1853.10

SHAFT VERSION

US version

- F. Involute splined shaft
- ANS B92.1 - 1970 standard
- Flat root side fit
- Pitch 12/24
- Teeth 14
- Major dia. 1.25 in
- Pressure angle 30°

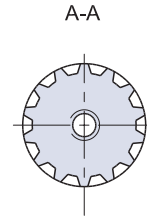
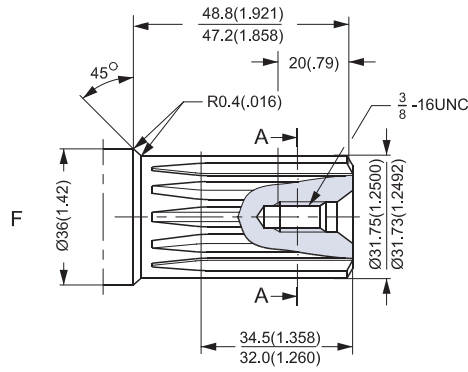

- G: Tapered shaft 35 mm (ISO/R775)
- I: DIN 937 NV 410
- Tightening torque: 200 ± 10 Nm (1770 ± 85 lbf.in)
- H: Taper 1:10
- L: Parallel key B6 × 6 × 20 DIN 6885

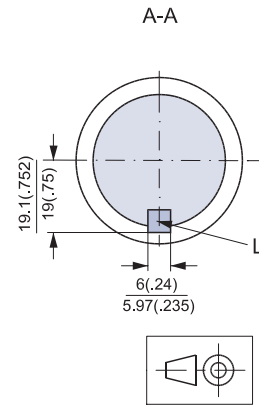
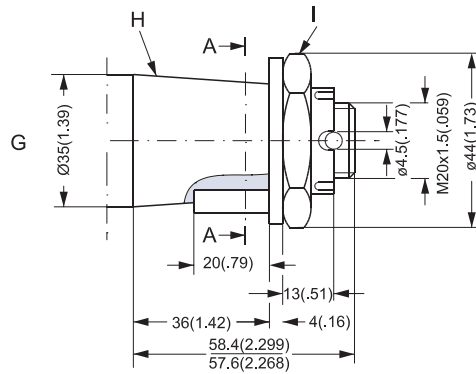

151-1854.10

PORT THREAD VERSIONS

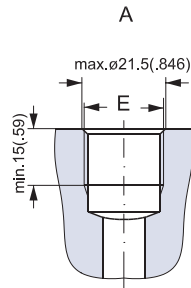

A: G main ports
E: ISO 228/1 - G^{1/2}

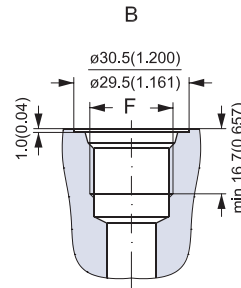

B: UNF main ports
F: ⁷/₈ - 14 UNF
O-ring boss port

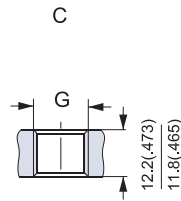

C: G drain port
G: ISO 228/1 - G^{1/4}

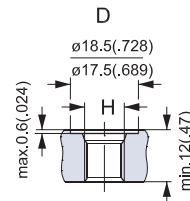

D: UNF drain port
H: ⁷/₁₆ - 20 UNF
O-ring boss port

151-1858.10

DIMENSIONS

Side port version with 4 hole oval mounting flange (A4-flange).

Type	L mm (in)	L ₁ mm (in)
OMH 200	170.1 (6.70)	27.8 (1.09)
OMH 250	177.1 (6.97)	34.8 (1.37)
OMH 315	185.8 (7.31)	43.5 (1.71)
OMH 400	197.1 (7.76)	54.8 (2.16)
OMH 500	207.3 (8.16)	65.0 (2.56)

C: Drain connection
G 1/4; 12 mm (0.47 in) deep
D: G 1/2; 15 mm (0.59 in) deep

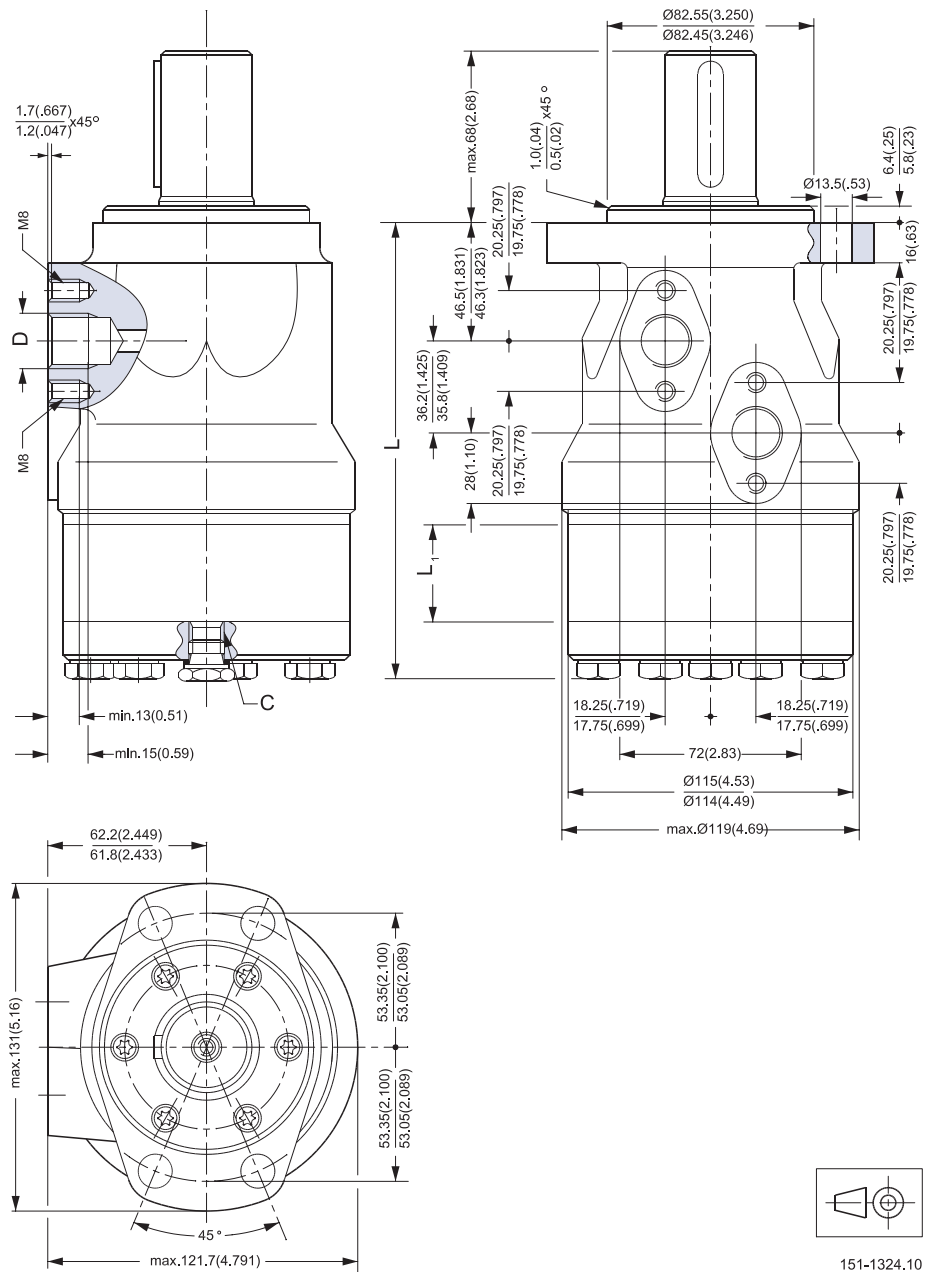

151-1324.10

DIMENSIONS

Side port version with 4 hole oval mounting flange (A4 flange).

Output shaft max.	L ₂ mm (in)
Splined shaft 1 in	50.5 (1.99)
Other shaft versions	58.0 (2.28)

Type	L mm (in)	L ₁ mm (in)
OMH 200	170.1 (6.70)	27.8 (1.09)
OMH 250	177.1 (6.97)	34.8 (1.37)
OMH 315	185.8 (7.31)	43.5 (1.71)
OMH 400	197.1 (7.76)	54.8 (2.16)
OMH 500	207.3 (8.16)	65.0 (2.56)

- C: Drain connection
 $\frac{7}{16}$ - 20 UNF;
 12 mm (0.47 in) deep
- D: $\frac{7}{8}$ - 14 UNF;
 15 mm (0.59 in) deep

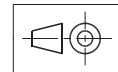
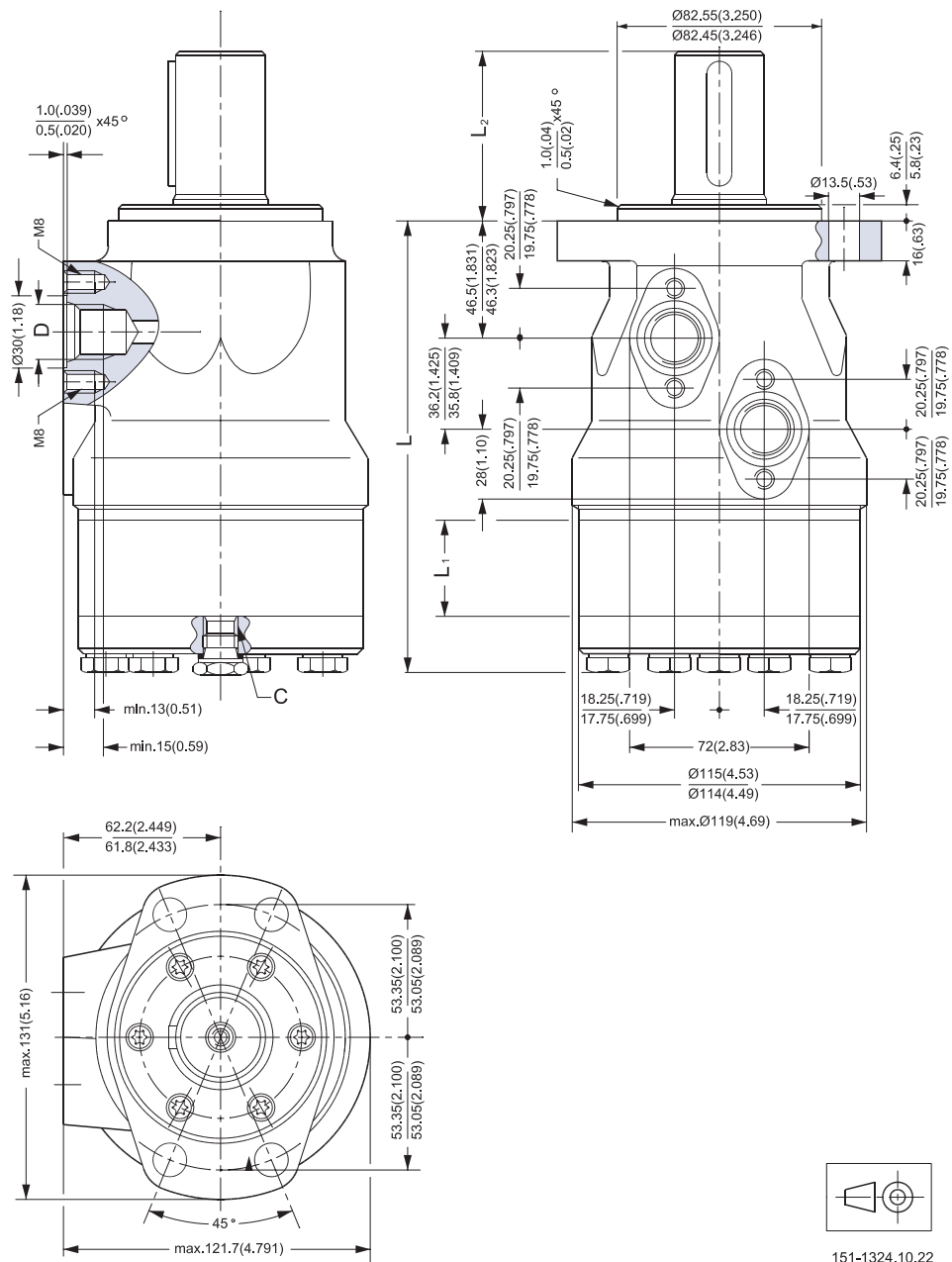

151-1324.10.22

VERSIONS

Mounting flange	Shaft	Port size	European version	US version	Clockwise shaft rotation (CW version) ¹⁾	Counter clockwise shaft rotation (CCW version) ¹⁾	Flange port version	Standard shaft seal	High pressure shaft seal	Drain connection	Check valve	Specials	Main type designation
Wheel	Tapered 35 mm	G 1/2	X		X		X		X	No	No		OMEW
	Tapered 35 mm	G 1/2	X			X	X		X	No	No		OMEW
	Tapered 1 1/4"	7/8 - 14 UNF		X	X		X		X	No	No		OMEW
	Tapered 1 1/4"	7/8 - 14 UNF		X		X	X		X	No	No		OMEW

Function diagram – see page : →

1) *Direction of rotation*

In the application mainly involves operation in one direction, we therefore recommend a corresponding motor with either CW- or CCW-rotation.

High pressure seals

Since all OMEW motors are fitted with a high-pressure shaft seal, there is no need for a drain line.

Features available (options) :

Painted

CODE NUMBERS

CODE NUMBERS	DISPLACEMENT [cm ³]						Technical data – Page	Dimensions – Page
	100	125	160	200	250	315		
151H	2002	2003	2004	2005	2006	2007	86	95
151H	2011	2012	2013	2014	2015	2016	86	95
151H	3002	3003	3004	3005	3006	3007	86	96
151H	3011	3012	3013	3014	3015	3016	86	96
	90	90	91	91	92	92		

Ordering

Add the four digit prefix “151H” to the four digit numbers from the chart for complete code number.

Example:

151H2015 for an OMEW 250 with 35 mm tapered shaft, port size G 1/2 and counter clockwise rotation (CCW).

Note: Orders will not be accepted without the four digit prefix.

TECHNICAL DATA FOR OMEW WITH 35 MM AND 1 1/4 IN TAPERED SHAFT

Type			OMEW	OMEW	OMEW	OMEW	OMEW	OMEW
Motor size			100	125	160	200	250	315
Geometric displacement	cm ³ (in ³)		99.8 (6.11)	124.1 (7.60)	155.4 (9.51)	198.2 (12.13)	248.1 (15.18)	310.1 (18.98)
Max. speed	min ⁻¹ (rpm)	cont.	600	475	375	300	240	190
		int. ¹⁾	750	695	470	375	300	240
Max. torque	Nm (lbf-in)	cont.	250 (2210)	320 (2830)	410 (3630)	470 (4160)	510 (4510)	520 (4600)
		int. ¹⁾	270 (2390)	340 (3010)	430 (3810)	510 (4510)	570 (5040)	640 (5660)
		peak ²⁾	290 (2570)	360 (3190)	460 (4070)	570 (5040)	640 (5660)	740 (6550)
Max. output	kW (hp)	cont.	12.0 (16.1)	12.0 (16.1)	12.0 (16.1)	11.0 (14.8)	10.0 (13.4)	8.0 (10.7)
		int. ¹⁾	15.0 (20.1)	15.0 (20.1)	15.0 (20.1)	14.0 (18.8)	12.0 (16.1)	10.0 (13.4)
Max. pressure drop	bar (psi)	cont.	200 (2900)	200 (2900)	200 (2900)	185 (2680)	160 (2320)	130 (1890)
		int. ¹⁾	210 (3050)	210 (3050)	210 (3050)	200 (2900)	180 (2610)	160 (2320)
		peak ²⁾	225 (3260)	225 (3260)	225 (3260)	225 (3260)	200 (2900)	185 (2680)
Max. oil flow	l/min (US gal/min)	cont.	60 (15.9)	60 (15.9)	60 (15.9)	60 (15.9)	60 (15.9)	60 (15.9)
		int. ¹⁾	75 (19.8)	75 (19.8)	75 (19.8)	75 (19.8)	75 (19.8)	75 (19.8)
Max. starting pressure with unloaded shaft	bar (psi)		10 (145)	7 (100)	7 (100)	7 (100)	7 (100)	7 (100)
Min. starting torque	at max. press. drop Nm (lbf-in)	cont.	230 (2040)	290 (2570)	360 (3190)	420 (3720)	460 (4070)	470 (4160)
		int. ¹⁾	240 (2120)	300 (2660)	380 (3360)	460 (4070)	520 (4600)	570 (5040)
Min. speed ³⁾	min ⁻¹ (rpm)		10	9	7	5	5	5

Type			Max. inlet pressure	Max. return pressure	
OMEW 100 - 315		bar (psi)	cont.	200 (2900)	200 (2900)
		bar (psi)	int. ¹⁾	210 (3050)	210 (3050)
		bar (psi)	peak ²⁾	225 (3260)	225 (3260)

¹⁾ Intermittent operation: the permissible values may occur for max. 10% of every minute.

²⁾ Peak load: the permissible values may occur for max. 1% of every minute.

³⁾ Operation at lower speeds may be slightly less smooth.

**MAX. PERMISSIBLE
SHAFT SEAL PRESSURE**

OMEW with high pressure shaft seal

CW version (clockwise rotation)

- 1) By clockwise rotation:
The shaft seal pressure equals the return pressure.
- 2) By counter clockwise rotation:
The shaft seal pressure equals the input pressure

CCW version (counter clockwise rotation)

- 1) By counter clockwise rotation:
The shaft seal pressure equals the return pressure.
- 2) By clockwise rotation:
The shaft seal pressure equals the input pressure

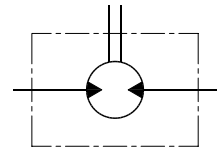

151-1743.10

Max. permissible shaft seal pressure

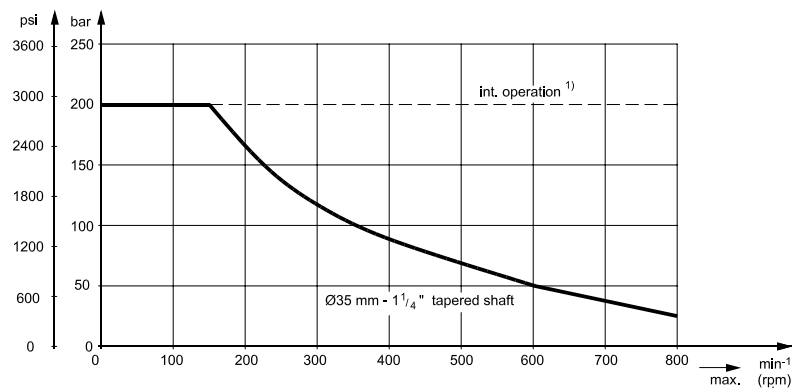

151-1861.10

¹⁾ Intermittent operation: the permissible values may occur for max. 10% of every minute.

**PRESSURE DROP IN
MOTOR**

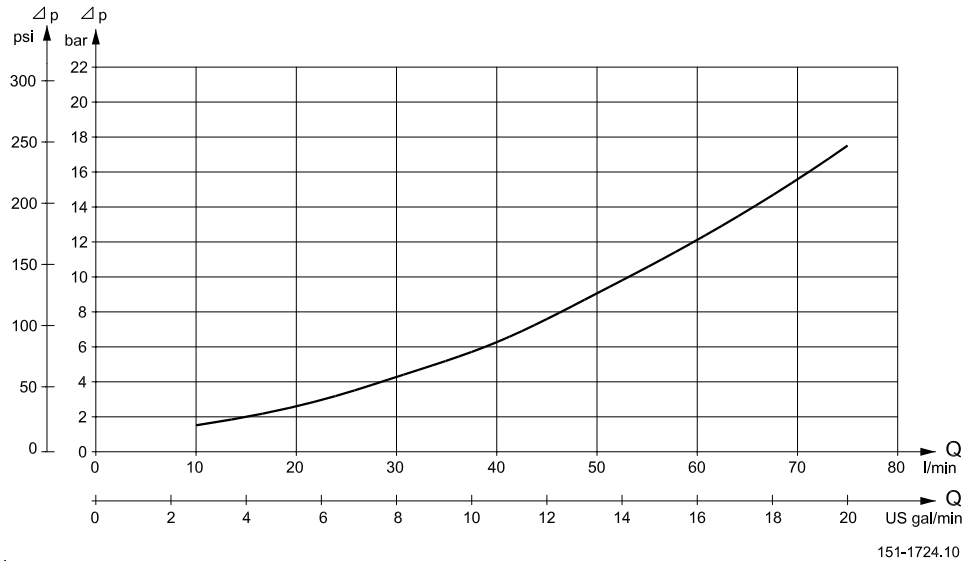

The curve applies to an unloaded motor shaft and an oil viscosity of 35 mm²/s (165 SUS)

**DIRECTION OF SHAFT
ROTATION**

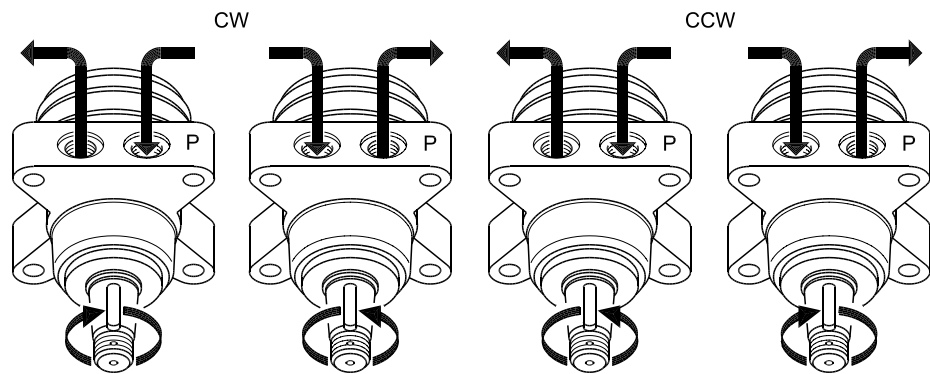

**PERMISSIBLE SHAFT
LOADS FOR OMEW**

As the OMEW output shaft is embedded in needle bearings and the mounting flange is recessed it is possible to fit a wheel hub direct onto the shaft so that the radial load acts midway between the needle bearings.

Based upon the requested max. speed and the point of action of the radial load the permissible shaft load can be read from the curved shown below.

Curve A shows the max. radial load. If the radial load exceeds these values there is a potential risk of breakdown.

The other curves apply to a B10 bearing life of 2000 hours at the indicated speed when applying a hydraulic mineral oil with an adequate content of anti-wear additives.

The longevity can also be calculated by means of the "Bearing dimensions" instructions in the technical information »General« DKMH.PK.100.G2.02 520L0232.

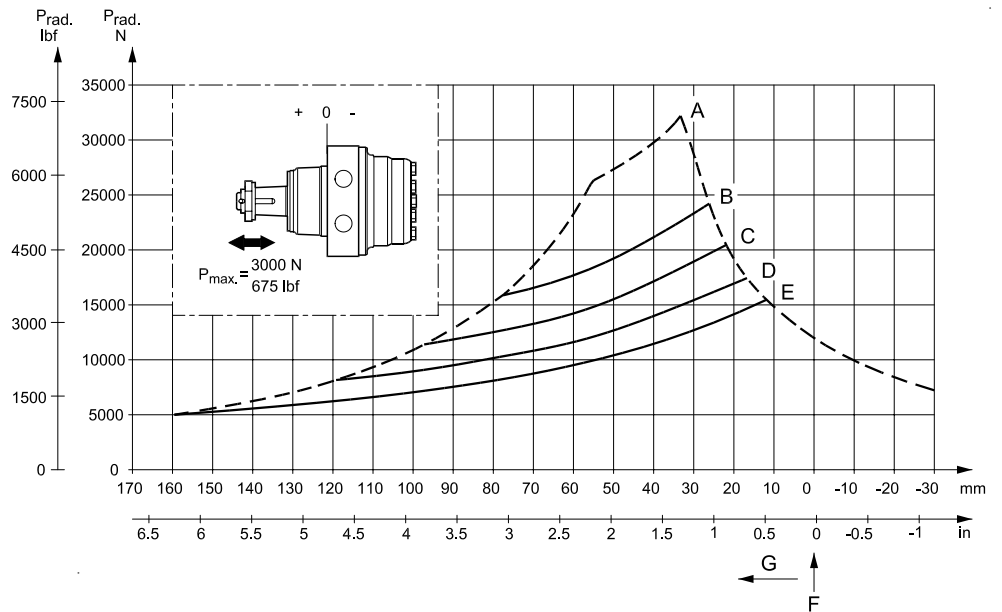

- A: Max. radial load
- B: $n = 50 \text{ min}^{-1}$ (rpm)
- C: $n = 100 \text{ min}^{-1}$ (rpm)
- D: $n = 200 \text{ min}^{-1}$ (rpm)
- E: $n = 400 \text{ min}^{-1}$ (rpm)
- F: Front flange
- G: Direction toward shaft

151-1725.10

FUNCTION DIAGRAMS

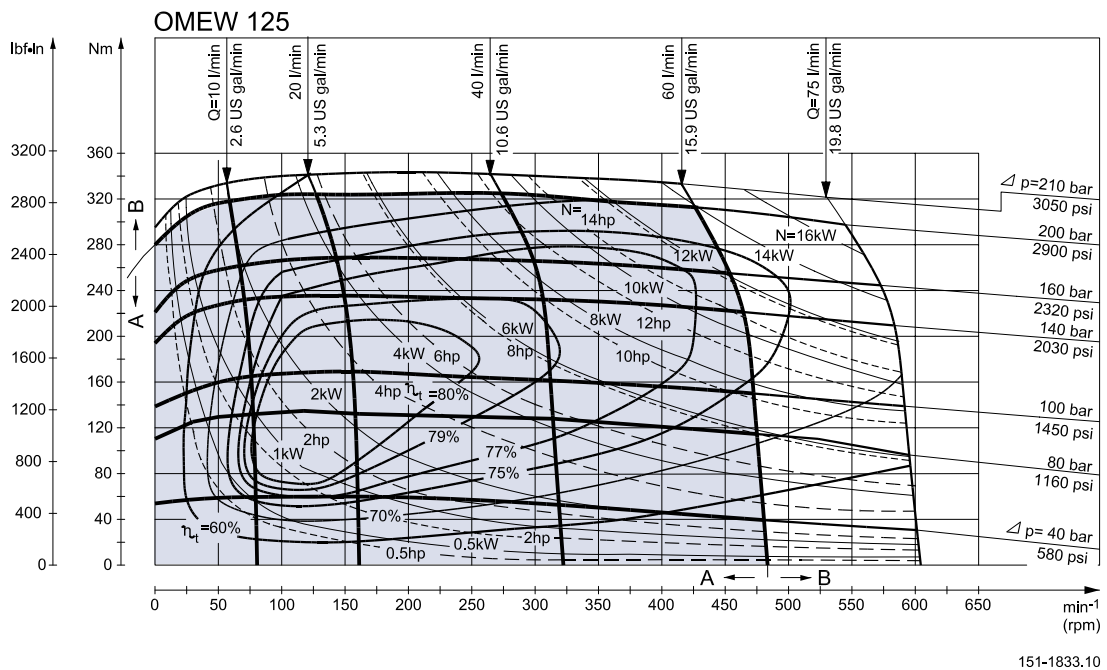
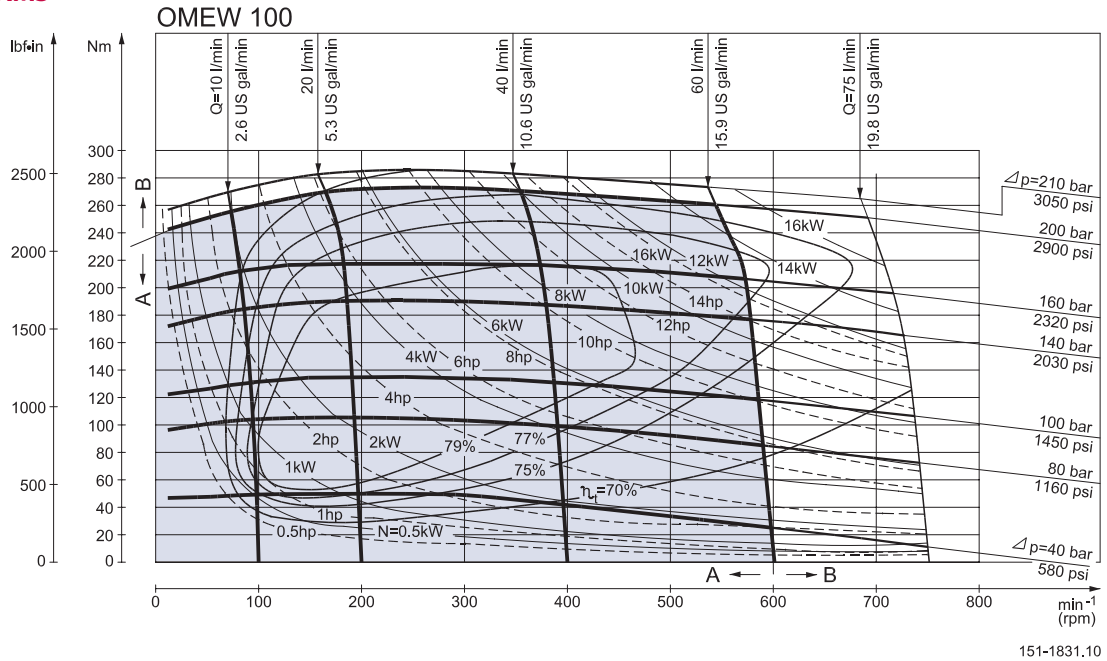

Explanation of function diagram use, basis and conditions can be found on page 7.

- A: Continuous range
- B: Intermittent range (max. 10% operation every minute)

Max. permissible continuous/intermittent pressure drop for the actual shaft version can be found on page 86.

Note: Intermittent pressure drop and oil flow must not occur simultaneously.

FUNCTION DIAGRAMS

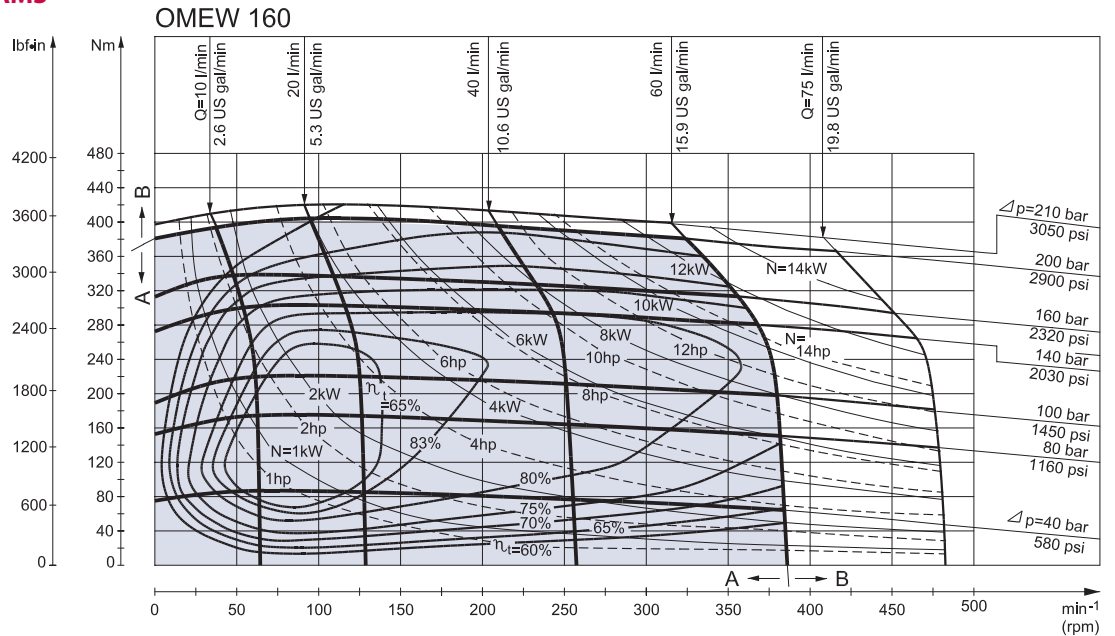

151-1830.10

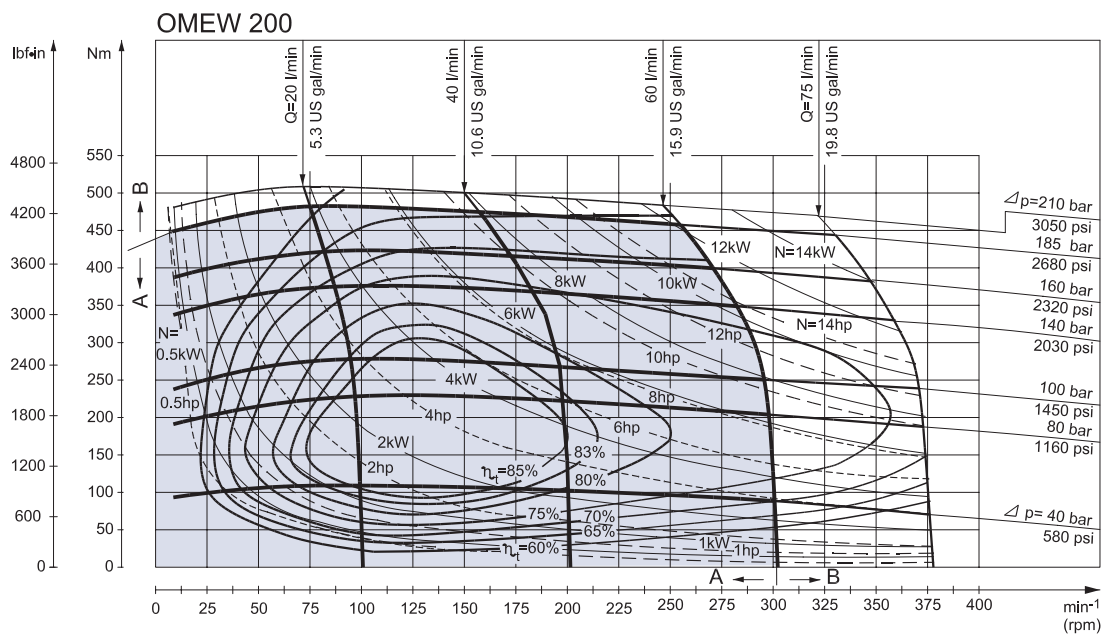

151-1832.10

Explanation of function diagram use, basis and conditions can be found on page 7.

- A: Continuous range
- B: Intermittent range (max. 10% operation every minute)

Max. permissible continuous/intermittent pressure drop for the actual shaft version can be found on page 86.

Note: Intermittent pressure drop and oil flow must not occur simultaneously.

FUNCTION DIAGRAMS

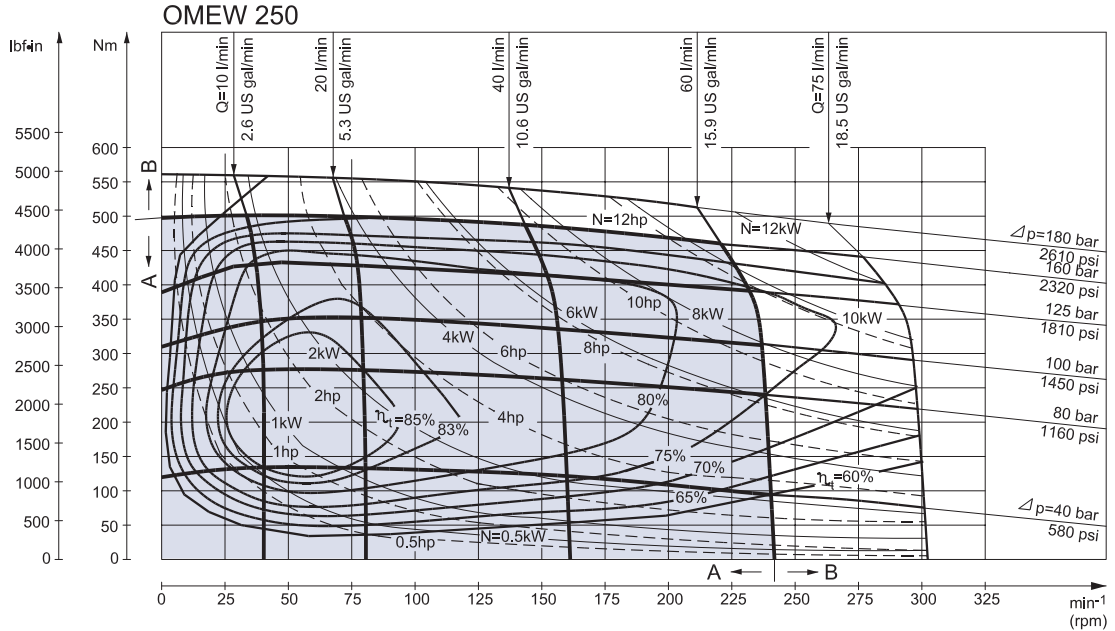

151-1834.10

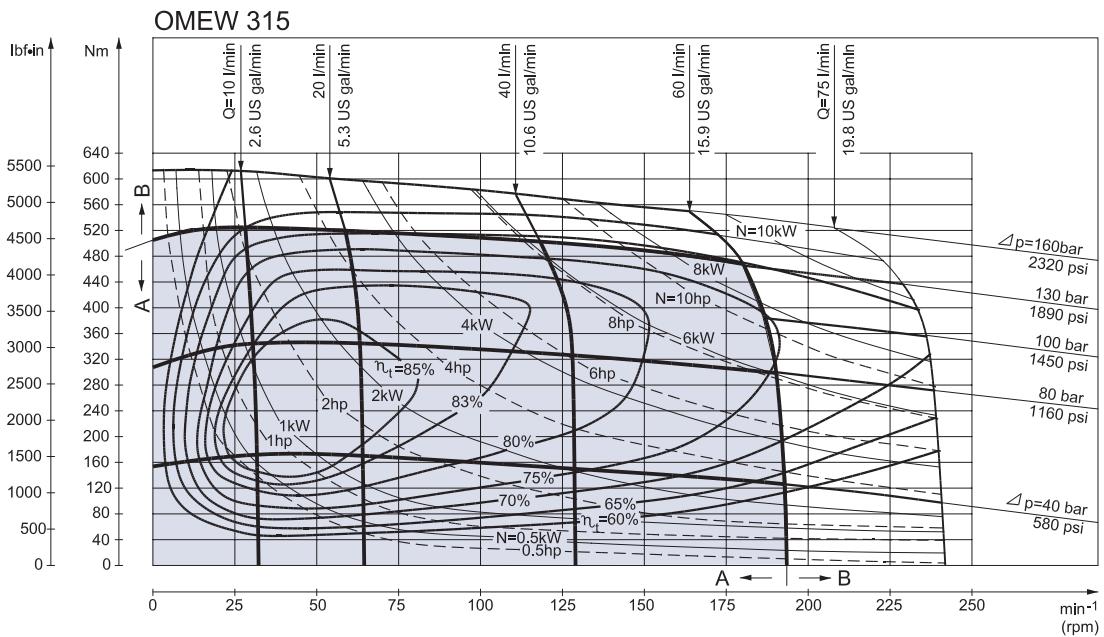

151-1835.10

Explanation of function diagram use, basis and conditions can be found on page 7.

- A: Continuous range
- B: Intermittent range (max. 10% operation every minute)

Max. permissible continuous/intermittent pressure drop for the actual shaft version can be found on page 86.

Note: Intermittent pressure drop and oil flow must not occur simultaneously.

SHAFT VERSION

- A: Tapered shaft 35 mm (ISO/R775)
- N: DIN 937 NV 41
Tightening torque:
200 ± 10 Nm (1770 ± 85 lbf·in)
- C: Taper 1:10
- F: Parallel key
B6 × 6 × 20
DIN 6885

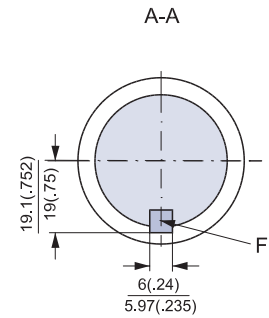
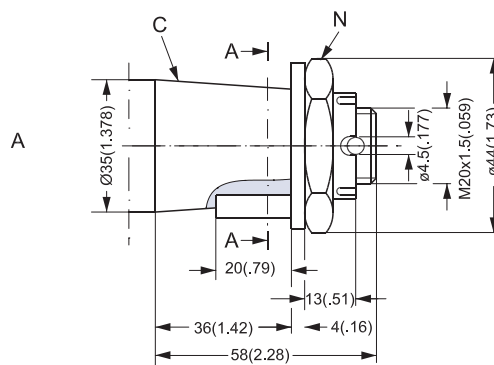

- B: Tapered shaft 1 1/4 in
- D: Cone 1:8
SAE J501
- E: 1 - 20 UNEF
Across flats 1 7/16
Tightening torque:
200 ± 10 Nm (1770 ± 85 lbf·in)
- G: Parallel key
5/16 × 5/16 × 1 1/4
SAE J501

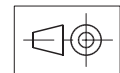
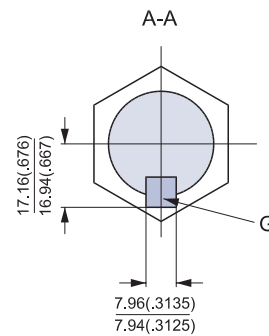
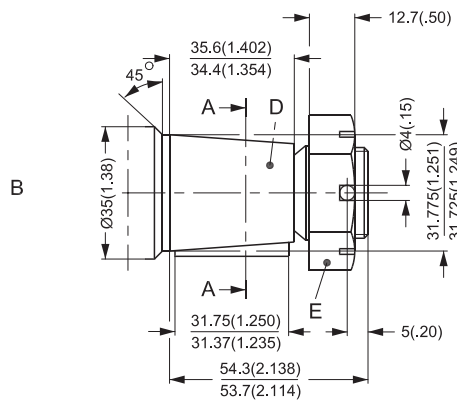

151-1860.10

PORT THREAD VERSIONS

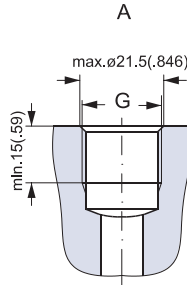

A: G main ports
G: ISO 228/1 - G¹/₂

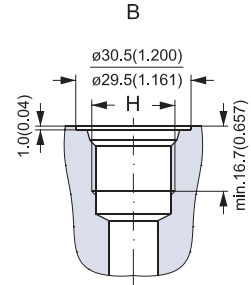

151-1857.10
B: UNF main ports
H: ⁷/₈ - 14 UNF
O-ring boss port

DIMENSIONS

Type	L mm (in)	L ₁ mm (in)
OMEW 100	107.9 (4.25)	14.0 (0.55)
OMEW 125	111.3 (4.38)	17.4 (0.69)
OMEW 160	115.7 (4.56)	21.8 (0.86)
OMEW 200	121.7 (4.79)	27.8 (1.09)
OMEW 250	128.7 (5.07)	34.8 (1.37)
OMEW 315	137.4 (5.41)	43.5 (1.71)

- D: G 1/2, 15 mm (0.59 in)
- G: Tapered shaft 35 mm (ISO/R775)
- J: DIN 937 NV 410
Tightening torque:
200 ± 10 Nm (1770 ± 85 lbf-in)
- K: Taper 1:10
- M: Parallel key
B6 × 6 × 20
DIN 6885

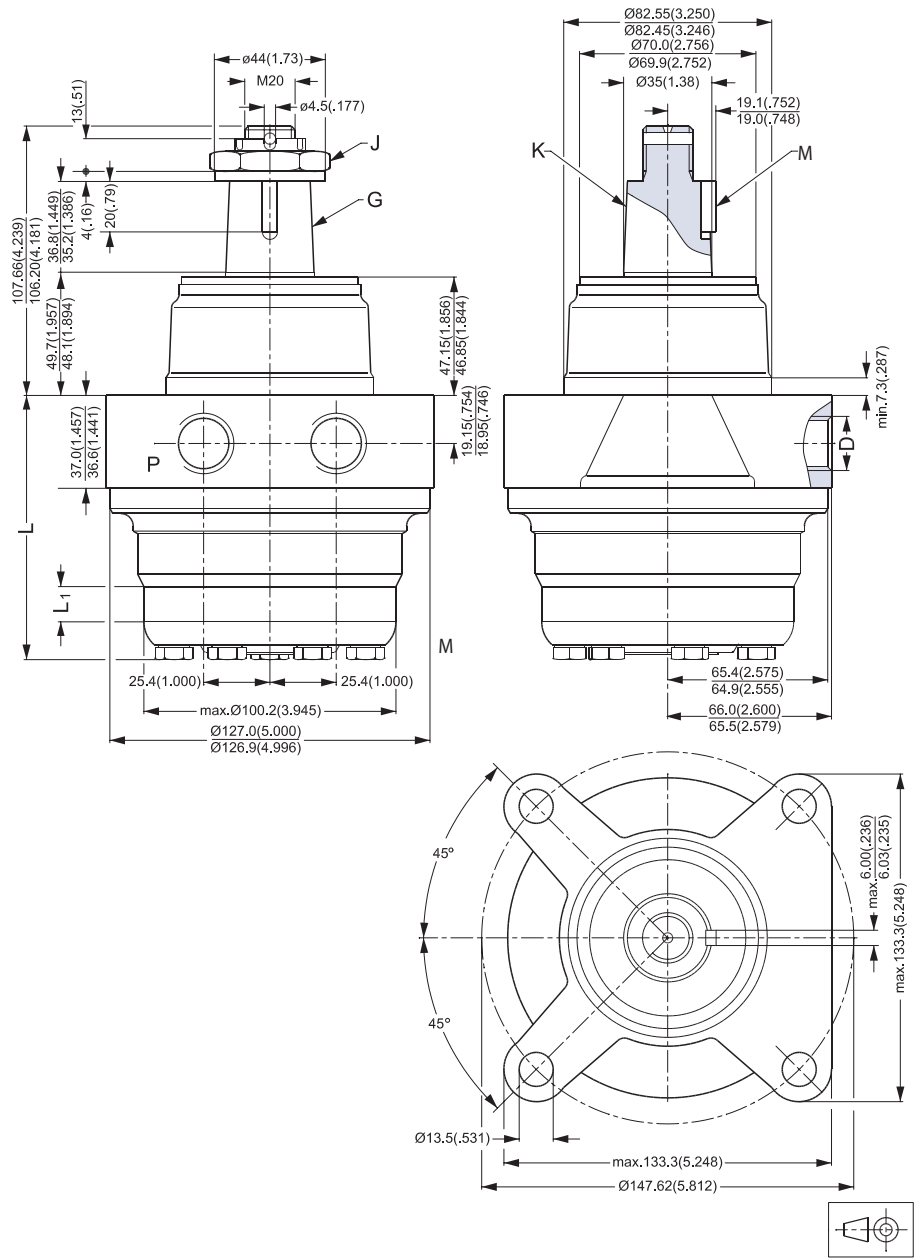

151-1723.10

DIMENSIONS

Type	L mm (in)	L ₁ mm (in)
OMEW 100	107.9 (4.25)	14.0 (0.55)
OMEW 125	111.3 (4.38)	17.4 (0.69)
OMEW 160	115.7 (4.56)	21.8 (0.86)
OMEW 200	121.7 (4.79)	27.8 (1.09)
OMEW 250	128.7 (5.07)	34.8 (1.37)
OMEW 315	137.4 (5.41)	43.5 (1.71)

- D: $\frac{7}{8}$ - 14 UNF;
16.7 mm (0.66 in) deep
- G: Tapered shaft $1\frac{1}{4}$ in (ISO/R775)
- J: Nut 1 - 20 UNEF
Across flats $1\frac{7}{16}$
Tightening torque:
 200 ± 10 Nm (1770 \pm 85 lbf-in)
- K: Taper 1:8
- M: Parallel key
 $\frac{5}{16} \times \frac{5}{16} \times 1\frac{1}{4}$
SAE J 501

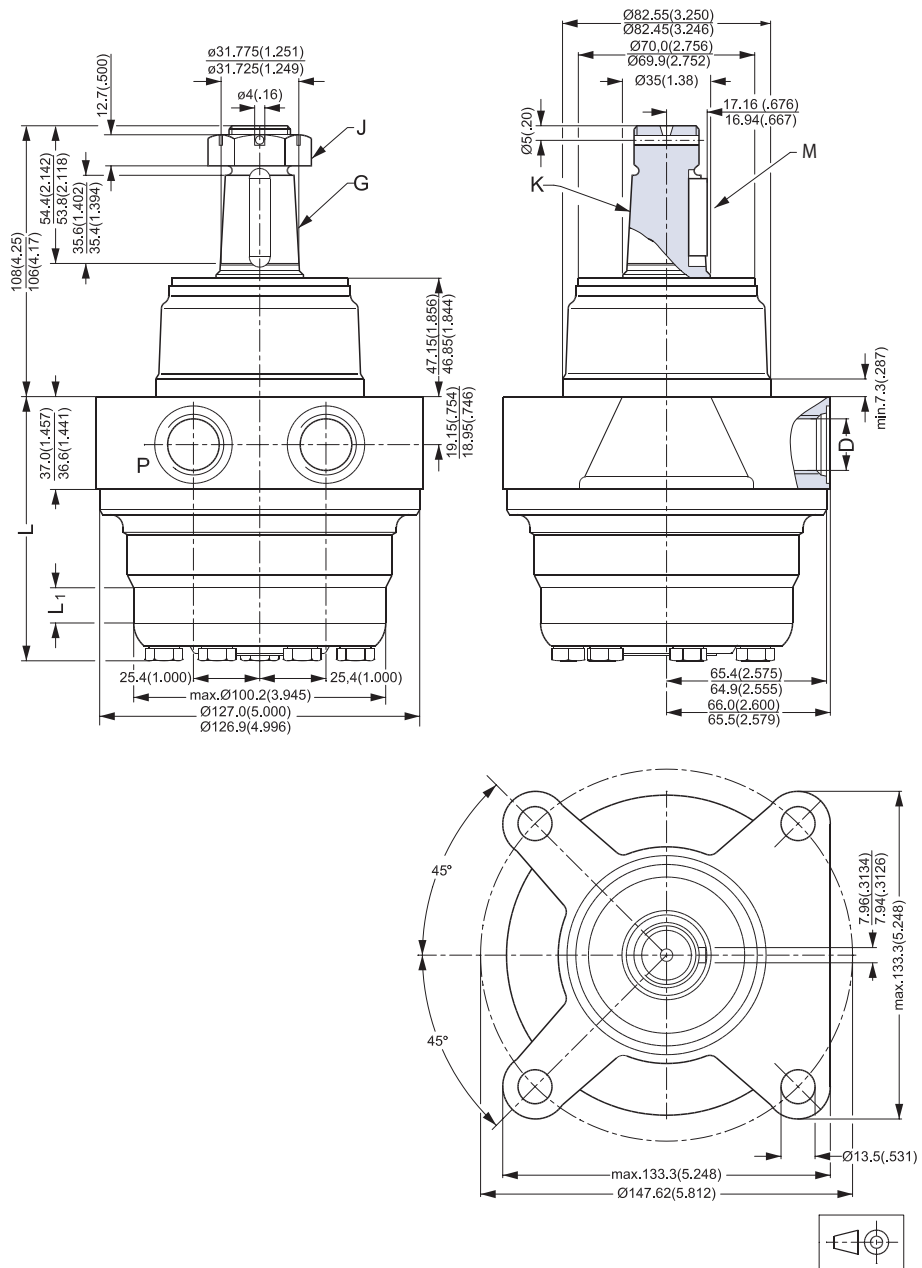

151-1723.10.22

WEIGHT OF MOTORS

Code no	Weight	
	kg	lb
151-0208	7.2	15.9
151-0242	6.9	15.2
151-0243	7.0	15.4
151-0244	7.5	16.5
151-0245	8.0	17.6
151-0246	9.0	19.8
151-0247	8.5	18.7
151-0248	6.7	14.8
151-0265	6.7	14.8
151-0266	6.9	15.2
151-0267	7.0	15.4
151-0268	7.5	16.5
151-0269	8.0	17.6
151-0270	9.0	19.8
151-0271	8.5	18.7
151-0300	5.6	12.3
151-0301	5.7	12.6
151-0302	5.9	13.0
151-0303	6.0	13.2
151-0304	6.2	13.7
151-0305	6.4	14.1
151-0306	6.6	14.6
151-0307	6.9	15.2
151-0308	7.4	16.3
151-0310	5.6	12.3
151-0311	5.7	12.6
151-0312	5.9	13.0
151-0313	6.0	13.2
151-0314	6.2	13.7
151-0315	6.4	14.1
151-0316	6.6	14.6
151-0317	6.9	15.2
151-0318	7.4	16.3
151-0330	5.6	12.3
151-0331	5.7	12.6
151-0332	5.9	13.0
151-0333	6.0	13.2
151-0334	6.2	13.7
151-0335	6.4	14.1
151-0336	6.6	14.6
151-0337	6.9	15.2
151-0338	7.4	16.3
151-0340	5.5	12.1
151-0341	5.5	12.1
151-0342	5.6	12.3
151-0400	6.7	14.8
151-0401	6.9	15.2
151-0402	7.0	15.4
151-0403	7.2	15.9

Code no	Weight	
	kg	lb
151-0404	7.5	16.5
151-0405	8.0	17.6
151-0406	8.5	18.7
151-0407	9.0	19.8
151-0408	9.5	20.9
151-0410	6.7	14.8
151-0411	6.9	15.2
151-0412	7.0	15.4
151-0413	7.2	15.9
151-0414	7.5	16.5
151-0415	8.0	17.6
151-0416	8.5	18.7
151-0417	9.0	19.8
151-0418	9.5	20.9
151-0420	6.7	14.8
151-0421	6.9	15.2
151-0422	7.0	15.4
151-0423	7.2	15.9
151-0424	7.5	16.5
151-0425	8.0	17.6
151-0426	8.5	18.7
151-0427	9.0	19.8
151-0428	9.5	20.9
151-0600	5.6	12.3
151-0601	5.7	12.6
151-0602	5.9	13.0
151-0603	6.0	13.2
151-0604	6.2	13.7
151-0605	6.4	14.1
151-0606	6.6	14.6
151-0607	6.9	15.2
151-0608	7.4	16.3
151-0610	5.6	12.3
151-0611	5.7	12.6
151-0612	5.9	13.0
151-0613	6.0	13.2
151-0614	6.2	13.7
151-0615	6.4	14.1
151-0616	6.6	14.6
151-0617	6.9	15.2
151-0618	7.4	16.3
151-0630	5.6	12.3
151-0631	5.7	12.6
151-0632	5.9	13.0
151-0633	6.0	13.2
151-0634	6.2	13.7
151-0635	6.4	14.1
151-0636	6.6	14.6
151-0637	6.9	15.2

Code no	Weight	
	kg	lb
151-0638	7.4	16.3
151-0640	5.5	12.1
151-0641	5.5	12.1
151-0642	5.6	12.3
151-0700	6.7	14.8
151-0701	6.9	15.2
151-0702	7.0	15.4
151-0703	7.2	15.9
151-0704	7.5	16.5
151-0705	8.0	17.6
151-0706	8.5	18.7
151-0707	9.0	19.8
151-0708	9.5	20.9
151-0710	6.7	14.8
151-0711	6.9	15.2
151-0712	7.0	15.4
151-0713	7.2	15.9
151-0714	7.5	16.5
151-0715	8.0	17.6
151-0716	8.5	18.7
151-0717	9.0	19.8
151-0718	9.5	20.9
151-0720	6.7	14.8
151-0721	6.9	15.2
151-0722	7.0	15.4
151-0723	7.2	15.9
151-0724	7.5	16.5
151-0725	8.0	17.6
151-0726	8.5	18.7
151-0727	9.0	19.8
151-0728	9.5	20.9
151-1208	5.6	12.3
151-1209	5.7	12.6
151-1210	5.9	13.0
151-1211	6.2	13.7
151-1212	6.4	14.1
151-1213	6.6	14.6
151-1214	6.9	15.2
151-1215	7.4	16.3
151-1217	6.0	13.2
151-1231	6.7	14.8
151-1232	6.9	15.2
151-1233	7.0	15.4
151-1234	7.5	16.5
151-1235	8.0	17.6
151-1236	8.5	18.7
151-1237	9.0	19.8
151-1238	7.2	15.9
151-1243	9.5	20.9

WEIGHT OF MOTORS

Code no	Weight	
	kg	lb
151-5001	5.6	12.3
151-5002	5.7	12.6
151-5003	5.9	13.0
151-5004	6.0	13.2
151-5005	6.2	13.7
151-5006	6.4	14.1
151-5007	6.6	14.6
151-5008	6.9	15.2
151-5009	7.4	16.3
151-5174	5.4	11.9
151-5191	6.1	13.4
151-5192	6.2	13.7
151-5193	6.4	14.1
151-5194	6.5	14.3
151-5195	6.7	14.8
151-5196	6.9	15.2
151-5197	7.1	15.7
151-5198	7.4	16.3
151-5199	7.9	17.4
151-5211	5.5	12.1
151-5212	5.6	12.3
151-5213	5.8	12.8
151-5214	5.9	13.0
151-5215	6.1	13.4
151-5216	6.3	13.9
151-5217	6.5	14.3
151-5218	6.8	15.0
151-5219	7.3	16.1
151-5301	5.5	12.1
151-5302	5.6	12.3
151-5303	5.8	12.8
151-5304	5.9	13.0
151-5305	6.1	13.4
151-5306	6.3	13.9
151-5307	6.5	14.3
151-5308	6.8	15.0
151-5309	7.3	16.1
151-6000	6.7	14.8
151-6001	6.9	15.2
151-6002	7.0	15.4
151-6003	7.2	15.9
151-6004	7.5	16.5
151-6005	8.0	17.6
151-6006	8.5	18.7
151-6007	9.0	19.8
151-6008	9.5	20.9
151-6010	6.7	14.8
151-6011	6.9	15.2
151-6012	7.0	15.4

Code no	Weight	
	kg	lb
151-6013	7.2	15.9
151-6014	7.5	16.5
151-6015	8.0	17.6
151-6016	8.5	18.7
151-6017	9.0	19.8
151-6018	9.5	20.9
151-6110	6.7	14.8
151-6111	6.9	15.2
151-6112	7.0	15.4
151-6113	7.2	15.9
151-6114	7.5	16.5
151-6115	8.0	17.6
151-6116	8.5	18.7
151-6117	9.0	19.8
151-6118	9.5	20.9
151-6190	7.3	16.1
151-6191	7.5	16.5
151-6192	7.6	16.8
151-6193	7.8	17.2
151-6194	8.1	17.9
151-6195	8.6	19.0
151-6196	9.1	20.1
151-6197	9.6	21.2
151-6198	10.1	22.3
151-6210	6.7	14.8
151-6211	6.9	15.2
151-6212	7.0	15.4
151-6213	7.2	15.9
151-6214	7.5	16.5
151-6215	8.0	17.6
151-6216	8.5	18.7
151-6217	9.0	19.8
151-6218	9.5	20.9
151-6294	9.5	20.9
151-6295	7.2	15.9
151-6296	9.5	20.9
151-6300	9.0	19.8
151-6301	9.4	20.7
151-6302	9.5	20.9
151-6303	9.7	21.4
151-6304	10.0	22.1
151-6305	10.5	23.1
151-6306	11.0	24.3
151-6307	11.5	25.4
151-6308	12.0	26.5
151-6430	9.0	19.8
151-6431	9.4	20.7
151-6432	9.5	20.9
151-6433	9.7	21.4

Code no	Weight	
	kg	lb
151-6434	10.0	22.1
151-6435	10.5	23.1
151-6436	11.0	24.3
151-6437	11.5	25.4
151-6438	12.0	26.5
151-7021	5.0	11.0
151-7022	5.1	11.2
151-7023	5.3	11.7
151-7024	5.4	11.9
151-7025	5.6	12.3
151-7026	5.8	12.8
151-7027	6.0	13.2
151-7028	6.3	13.9
151-7029	6.8	15.0
151-7041	5.6	12.3
151-7042	5.7	12.6
151-7043	5.9	13.0
151-7044	5.4	11.9
151-7045	6.2	13.7
151-7046	6.4	14.1
151-7047	6.6	14.6
151-7048	6.9	15.2
151-7049	7.4	16.3
151-7061	5.0	11.0
151-7062	5.1	11.2
151-7063	5.3	11.7
151-7065	5.6	12.3
151-7066	5.8	12.8
151-7067	6.0	13.2
151-7068	6.3	13.9
151-7069	6.8	15.0
151-7080	5.4	12.0
151-7081	5.4	12.0
151-7082	5.6	12.3
151-7101	5.5	12.1
151-7102	5.6	12.3
151-7103	5.8	12.8
151-7104	5.9	13.0
151-7105	6.1	13.4
151-7106	6.3	13.9
151-7107	6.5	14.3
151-7108	6.8	15.0
151-7109	7.3	16.1
151-7240	6.7	14.8
151-7241	6.9	15.2
151-7242	7.0	15.4
151-7243	7.2	15.9
151-7244	7.5	16.5
151-7245	8.0	17.6

WEIGHT OF MOTORS

Code no	Weight	
	kg	lb
151-7246	8.5	18.7
151-7247	9.0	19.8
151-7248	9.5	20.9
151-7250	6.7	14.8
151-7251	6.9	15.2
151-7252	7.0	15.4
151-7253	7.2	15.9
151-7254	7.5	16.5
151-7255	8.0	17.6
151-7256	8.5	18.7
151-7257	9.0	19.8
151-7258	9.5	20.9
151-7260	6.1	13.4
151-7261	6.3	13.9
151-7262	6.4	14.1
51-7263	6.6	14.6
151-7264	6.9	15.2
151-7265	7.4	16.3
151-7266	7.9	17.4
151-7267	8.4	18.5
151-7269	8.9	19.6
151H1002	10.5	23.1
151H1003	11.0	24.3
151H1004	11.5	25.4
151H1005	12.3	27.1
151H1006	13.0	28.7
151H1012	10.5	23.1
151H1013	11.0	24.3
151H1014	11.5	25.4
151H1015	12.3	27.1
151H1016	13.0	28.7
151H1022	10.5	23.1
151H1023	11.0	24.3
151H1024	11.5	25.4
151H1025	12.3	27.1
151H1026	13.0	28.7
151H1034	11.5	25.4
151H1035	12.3	27.1
151H1036	13.0	28.7
151H1042	10.5	23.1
151H1043	11.0	24.3
151H1044	11.5	25.4
151H1045	12.3	27.1
151H1046	13.0	28.7
151H1052	10.5	23.1
151H1053	11.0	24.3
151H1054	11.5	25.4
151H1055	12.3	27.1
151H1056	13.0	28.7

Code no	Weight	
	kg	lb
151H1080	10.5	23.1
151H1081	13.0	28.7
151H1082	11.0	24.3
151H1083	11.5	25.4
151H1084	12.3	27.1
151H2002	9.3	20.5
151H2003	9.5	20.9
151H2004	9.8	21.6
151H2005	10.3	22.7
151H2006	10.8	23.8
151H2007	11.3	24.9
151H2011	9.3	20.5
151H2012	9.5	20.9
151H2013	9.8	21.6
151H2014	10.3	22.7
151H2015	10.8	23.8
151H2016	11.3	24.9
151H3002	9.3	20.5
151H3003	9.5	20.9
151H3004	9.8	21.6
151H3005	10.3	22.7
151H3006	10.8	23.8
151H3007	11.3	24.9
151H3011	9.3	20.5
151H3012	9.5	20.9
151H3013	9.8	21.6
151H3014	10.3	22.7
151H3015	10.8	23.8
151H3016	11.3	24.9



OUR PRODUCTS

Hydrostatic transmissions
Hydraulic power steering
Electric power steering
Closed and open circuit axial piston pumps and motors
Gear pumps and motors
Bent axis motors
Radial piston motors
Orbital motors
Transit mixer drives
Planetary compact gears
Proportional valves
Directional spool valves
Cartridge valves
Hydraulic integrated circuits
Hydrostatic transaxles
Integrated systems
Fan drive systems
Electrohydraulic controls
Digital electronics and software
Battery powered inverter
Sensors

Sauer-Danfoss Hydraulic Power Systems – Market Leaders Worldwide

Sauer-Danfoss is a comprehensive supplier providing complete systems to the global mobile market.

Sauer-Danfoss serves markets such as agriculture, construction, road building, material handling, municipal, forestry, turf care, and many others.

We offer our customers optimum solutions for their needs and develop new products and systems in close cooperation and partnership with them.

Sauer-Danfoss specializes in integrating a full range of system components to provide vehicle designers with the most advanced total system design.

Sauer-Danfoss provides comprehensive worldwide service for its products through an extensive network of Authorized Service Centers strategically located in all parts of the world.

Sauer-Danfoss (US) Company
2800 East 13th Street
Ames, IA 50010, USA
Phone: +1 515 239-6000, Fax: +1 515 239 6618

Sauer-Danfoss (Neumünster) GmbH & Co. OHG
Postfach 2460, D-24531 Neumünster
Krokamp 35, D-24539 Neumünster, Germany
Phone +49 4321 871-0, Fax: +49 4321 871 122

Sauer-Danfoss (Nordborg) A/S
DK-6430 Nordborg, Denmark
Phone: +45 7488 4444, Fax: +45 7488 4400

www.sauer-danfoss.com